

SF60 thermal image IP hybrid series - UL range

Fixed camera station,
ordinary location



Overview

The Oxalis SF60 thermal imager is a fixed camera housing for use in onshore, offshore, marine and heavy industrial environments where thermal imaging is required for specific process or security applications. The large format housing allows the installation of customised equipment (subject to conformity).

The camera housings are designed specifically for the Americas markets or where UL ordinary location standards have been specified and as a result they utilise NPT entries as standard to maximise compatibility with existing installations.

Our camera stations are designed and manufactured for longevity in harsh environments, require minimal maintenance and are fully certified to UL standards.

See separate datasheets for other global certification ranges.

Features

- Electro-polished 316L stainless steel on all welded assemblies
- Camera station window in toughened glass
- Pole or wall mounting options (see separate datasheets)
- NPT entries as standard
- 5 different size lens options
- 4 resolution/frequency rating options
- Various camera module options
- Options also available for IP, analogue, hybrid, IP over Coax and direct fibre out* - see specific datasheet
- Supply voltage options (24 VAC, 110 or 230 VAC, 50/60Hz)
- -58°F to +158°F* operating temperature
- IP66/67

*Model dependent



Specification

Features	
Sun shield	Standard stainless steel 316L mirror finish
Integral wiper	Optional (silicone wiper blades that are resistant and do not perish after long exposure to ozone, UV, ice, snow, heat or cold)
Integral demister	Standard
Washer systems	Compatible with Oxalis SW Washer tanks (see separate datasheets)
Telemetry receiver	Integral - Pelco D standard protocol (others to specification)
Integral IP encoder	Includes integral video encoder, H.264 / M-JPEG/MPEG-4, low latency, triple streaming, D1, 2CIF, CIF and VGA Resolution, 25fps (30fps - NTSC) for use with analogue camera modules Optional nonstandard encoder, subject to acceptance, conformity to regulation and testing.
IP direct fibre out options	Optional integrated media converter, simplex singlemode 9/125µm or multimode 50/125µm, 10/100Mb ethernet, IEEE 802.3.
IP over coax	Optional integrated IP ethernet-over-coax converter (must be used with compatible Rx equipment)
Electrical	
Supply voltage options	24 VAC, 110 or 230 VAC, 50/60Hz
Power consumption	37W maximum (65W with low temperature operation)
Electrical connections	Terminal block for power, data and video specific to camera configuration
Cable entry	2 x ¾" NPT located in rear flange
Mechanical	
Body material	Electro-polished 316L stainless steel on all welded assemblies
Fixings material	A4 stainless steel
Camera station window	Internal AR and external carbon coated germanium (50 or 90mm Ø)
Mounting options	Pole or wall (see separate datasheets)
Operating temperature	From -58°F to +158°F (model dependent)
Weight (lb)	Up to 29lb depending on configuration
Ingress protection rating	IP66/67

Thermal core module options

T336 7.5-8.3Hz	Uncooled VOx microbolometer thermal imaging camera, including TCI Interface PCB for functionality over standard RS485 protocol Commands 336 x 256 resolution, 17µ pixel size, 7.5Hz NTSC/8.3Hz PAL exportable frame rate, digital detail enhancement
T640 7.5-8.3Hz	Uncooled VOx microbolometer thermal imaging camera, including TCI Interface PCB for functionality over standard RS485 protocol Commands. 640 x 512 resolution (PAL), 17µ pixel size, 7.5Hz NTSC/8.3Hz PAL exportable frame rate, digital detail enhancement
T336 25-30Hz	Uncooled VOx microbolometer thermal imaging camera, including TCI Interface PCB for functionality over standard RS485 protocol Commands 336 x 256 resolution, 17µ pixel size, 30Hz NTSC/25Hz PAL frame rate, digital detail enhancement. Subject to export restrictions and licensing
T640 25-30Hz	Uncooled VOx microbolometer thermal imaging camera, including TCI Interface PCB for functionality over standard RS485 protocol Commands. 640 x 512 resolution (PAL), 17µ pixel size, 30Hz NTSC/25Hz PAL frame rate, digital detail enhancement. Subject to export restrictions and licensing

Thermal core lens options

19mm lens	FoV 17° x 13° (336 x 256) / FoV 32° x 26° (640 x 512) Detection of object 4m x 1.5m: Typical 1550m
25mm lens	FoV 13° x 10° (336 x 256) / FoV 25° x 20° (640 x 512) Detection of object 4m x 1.5m: Typical 2200m
35mm lens	FoV 9.3° x 7.1° (336 x 256) / FoV 18° x 14° (640 x 512) Detection of object 4m x 1.5m: Typical 3000m
50mm lens	FoV 6.5° x 5° (336 x 256) / FoV 12.4° x 9.9° (640 x 512) Detection of object 4m x 1.5m: Typical 3900m
100mm lens	FoV 3.3° x 2.5° (336 x 256) / FoV 6.2° x 5.0° (640 x 512) Detection of object 4m x 1.5m: Typical 6000m. Ø90 Germanium housings only

General arrangement drawing (dimensions in inches and mm)

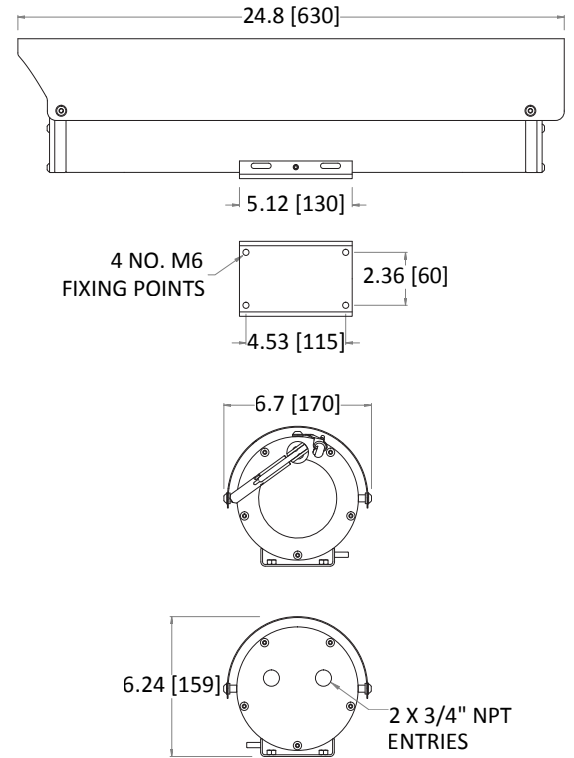

Ordering requirements

The following code is designed to help in selection of the correct unit. Build up the reference number by inserting the code for each component into the appropriate box

SF60														
------	--	--	--	--	--	--	--	--	--	--	--	--	--	--

Housing type	Code
Thermal imaging housing with 50mm germanium window	T
Thermal imaging housing with 90mm germanium window no camera	H

Wiper options	Code
Integral wiper with switched 24VAC for external washer pump	E
No wiper	N

Video type	Code
Integral IP video encoder	H
Hybrid analogue IP system with nonstandard IP encoder	S

Day/night module	Code
No D/N camera fitted	N

Thermal core module	Code
T336 7.5-8.3Hz	8
T640 7.5-8.3Hz	2
T336 25-30Hz	9
T640 25-30Hz	4
Customer specific thermal camera	C

Thermal core lens	Code
19mm lens	1
25mm lens	2
35mm lens	3
50mm lens	4
100mm lens	5
Customer specific thermal imaging lens	C

Transmission type	Code
Standard electrical	0
Simplex singlemode 9/125µm ethernet	3
Simplex multimode 50/125µm ethernet	4
IP over coax	5
Customer specific fibre transmission device	C

Temperature type	Code
-4°F to +158°F	E
-58°F to +158°F	F
-4°F to +122°F	G
-58°F to +122°F	H

Certification	Code
UL listed	P

Protocol requirements	Code
Pelco D protocol, baud rate 2400bps	D
Special - price on application	S

Camera rotation	Code
Not applicable	N

Supply voltage	Code
24 VAC ±10% 50/60 Hz	1
110 VAC ±10% 50/60 Hz	2
230 VAC ±10% 50/60 Hz	3
Special - price on application	S

Video system	Code
PAL	P
NTSC	N