

ABB INDUSTRIAL DRIVES

ACS880-07 drives (45 to 710 kW, 50 to 700 hp)

Hardware manual



ACS880-07 drives (45 to 710 kW, 50 to 700 hp)

Hardware manual

Table of contents



1. Safety instructions



4. Mechanical installation



6. Electrical installation



9. Start-up



Table of contents

1 Safety instructions

Contents of this chapter	15
Use of warnings and notes	15
General safety in installation, start-up and maintenance	16
Electrical safety in installation, start-up and maintenance	18
Electrical safety precautions	18
Additional instructions and notes	19
Optical components	20
Printed circuit boards	20
Grounding	20
General safety in operation	22
Additional instructions for permanent magnet motor drives	22
Safety in installation, start-up, maintenance	22
Safety in operation	23

2 Introduction to the manual

Contents of this chapter	25
Target audience	25
Categorization by frame size and option code	25
Quick installation, commissioning and operation flowchart	26
Terms and abbreviations	26
Related manuals	28

3 Operation principle and hardware description

Contents of this chapter	31
Product overview	31
Single-line circuit diagram of the drive	32
Block diagram of the brake and DC options (+D150, +D151 and +H356)	33
General information on the cabinet layout	34
Cabinet layout of frames R6 to R8	35
Cabinet layout of frames R6 to R8 with option +C129	36
Cabinet layout of frames R6 to R8 with options +C129 and +F289	37
Cabinet layout of frame R9	39
Cabinet layout of frame R9 with options +C129 and +F289	41
Cabinet layout of frames R10 and R11 – bottom entry and exit of cables	43
Cabinet layout of frames R10 and R11 – top entry and exit of cables (option +C129) ..	45
Overview of power and control connections	46
Door switches and lights	48
Main switch-disconnector (Q1)	48
Other devices on the door	48
Control panel	49
Control by PC tools	49
Descriptions of options	49
Degree of protection	49
Definitions	49

IP22 (UL Type 1)	50
IP42 (UL Type 1 Filtered) (option +B054)	50
IP54 (UL Type 12) (option +B055)	50
Marine construction (option +C121)	50
Cooling air intake through bottom of cabinet (option +C128)	50
UL Listed (option +C129)	50
Channeled air outlet (option +C130)	50
CSA Approved (option +C134)	51
Plinth height (options +C164 and +C179)	51
Seismic design (option +C180)	51
Empty cubicles on right (options +C196...C198)	51
Empty cubicles on left (options +C199...C201)	51
Resistor braking (options +D150 and +D151)	51
du/dt filter (option +E205)	51
Sine filter (option +E206)	51
Common mode filter (option +E208)	52
Molded case circuit breaker (MCCB, option +F289)	52
Cabinet heater with external supply (option +G300)	52
Cabinet lighting (option +G301)	52
Terminals for external control voltage (option +G307)	52
Output for motor space heater (option +G313)	52
Ready/Run/Fault lights (options +G327...G329)	53
Halogen-free wiring and materials (option +G330)	53
V-meter with selector switch (option +G334)	53
A-meter in one phase (option +G335)	53
Wire markings	53
Standard wiring	53
Additional wire markings	54
Bottom cable entry/exit (options +H350 and +H352)	54
Top cable entry/exit (options +H351 and +H353)	54
Cable conduit entry (option +H358)	54
Additional terminal block X504 (option +L504)	54
Thermal protection with PTC relays (options +L505, +2L505, +L513, +2L513, +L536, +L537)	55
+L505, +2L505, +L513, +2L513	55
+L536, +L537	55
Thermal protection with Pt100 relays (options +nL506, +nL514)	56
Starter for auxiliary motor fan (options +M6xx)	56
What the option contains	56
Description	57
Type designation label	58
Type designation key	59
Basic codes	59
Option codes	59

4 Mechanical installation

Contents of this chapter	65
Examining the installation site	65
Necessary tools	66
Moving the drive in its package	66
Horizontal package	66
Vertical package	68

Unpacking the transport package	69
Lifting the cabinet	70
Lifting from the cabinet from the horizontal package	70
Lifting the cabinet with crane	71
Lifting lugs	71
Certificate of conformity	71
Declaration of Conformity	72
Moving the cabinet after unpacking	73
Moving the cabinet with rollers	74
Moving the cabinet to its final placement with a slate bar	74
Moving the cabinet on its back	74
Installing the IP54 roof	75
Frames R6 to R8	75
Frame R9	76
Frames R10 and R11	76
Attaching the cabinet to the floor and wall or roof	77
General rules	77
Attaching the cabinet (non-marine units)	78
Alternative 1 – Clamping	78
Alternative 2 – Using the holes inside the cabinet	79
Alternative 3 – Cabinets with plinth options +C164 and +C179	80
Attaching the cabinet (marine units)	81
Miscellaneous	82
Cable duct in the floor below the cabinet	82
Arc welding	82
Air inlet through the bottom of cabinet (option +C128)	82
Air outlet duct on the cabinet roof (option +C130)	83
Calculating the required static pressure difference	84

5 Guidelines for planning the electrical installation

Contents of this chapter	85
Limitation of liability	85
Selecting the supply disconnecting device	85
Selecting the main contactor	85
Examining the compatibility of the motor and drive	86
Protecting the motor insulation and bearings	86
Requirements table	86
Availability of du/dt filter and common mode filter by drive type	89
Additional requirements for explosion-safe (EX) motors	89
Additional requirements for ABB motors of types other than M2_, M3_, M4_, HX_ and AM_	89
Additional requirements for ABB high-output and IP23 motors	89
Additional requirements for non-ABB high-output and IP23 motors	89
Additional data for calculating the rise time and the peak line-to-line voltage	90
Additional note for sine filters	91
Selecting the power cables	91
General guidelines	91
Typical power cable sizes	92
Power cable types	92
Preferred power cable types	92
Alternate power cable types	93
Not allowed power cable types	94

Additional guidelines, North America	94
Metal conduit	95
Power cable shield	95
Planning the resistor braking system	96
Selecting the control cables	96
Shielding	96
Signals in separate cables	96
Signals that can be run in the same cable	96
Relay cable	96
Control panel to drive cable	97
PC tool cable	97
Routing the cables	97
General guidelines – IEC	97
General guidelines – North America	98
Continuous motor cable shield/conduit or enclosure for equipment on the motor cable	98
Separate control cable ducts	99
Protecting the drive, input power cable, motor and motor cable in short circuit situations and against thermal overload	99
Protecting the drive and input power cable in short-circuit situations	99
Protecting the motor and motor cable in short-circuits	99
Protecting the drive and the power cables against thermal overload	100
Protecting the motor against thermal overload	100
Protecting the motor against overload without thermal model or temperature sensors .	100
Protecting the drive against ground faults	100
Residual current device compatibility	100
Implementing the emergency stop function	101
Implementing the Safe torque off function	101
Implementing the Prevention of unexpected start-up function	101
Implementing an ATEX-certified motor thermal protection	101
Implementing the functions provided by the FSO-xx safety functions module	102
Implementing the power loss ride-through function	102
Supplying power for the auxiliary circuits	103
Using power factor compensation capacitors with the drive	103
Using a safety switch between the drive and the motor	103
Implementing the control of a contactor between drive and motor	104
Implementing a bypass connection	104
Protecting the contacts of relay outputs	104
Implementing a motor temperature sensor connection	105
Connecting motor temperature sensor to the drive via an option module	106

6 Electrical installation

Contents of this chapter	109
Safety	109
Measuring the insulation	109
Measuring the insulation of the drive	109
Measuring the insulation of the input power cable	109
Measuring the insulation of the motor and motor cable	110
Custom brake resistor assembly	110
Grounding system compatibility check	111
Corner-grounded and midpoint-grounded 525...690 V delta systems	111

Connecting the power cables	112
Connection diagram	112
Layout of the power cable connection terminals and entries (frames R6 to R8)	113
Layout of the power cable connection terminals and entries (frames R6 to R8 with option +C129)	114
Layout of the power cable connection terminals and entries (frames R6 to R8 with options +C129+F277+F289)	115
Layout of the input and motor cable connection terminals (frame R9 with option +E205)	116
Layout of the power cable connection terminals and entries (frame R9 with option +C129)	117
Layout of the input and motor cable connection terminals (frames R10 and R11)	118
Layout of the input and motor cable connection terminals (frames R10 and R11 with option +C129)	118
Entry of external resistor and DC cables	118
Connection procedure (IEC)	119
Connection procedure (US)	120
Grounding the motor cable shield at the motor end	121
DC connection (option +H356)	121
Connecting the control cables	121
Control cable connection procedure	122
Grounding the outer shields of the control cables at the cabinet entry	122
Routing the control cables inside the cabinet (frames R6 to R8)	124
Routing the control cables inside the cabinet (frame R9)	125
Routing the control cables inside the cabinet (frames R10 and R11)	126
Connecting the control unit cables	126
Connecting a 230/115 V AC auxiliary voltage supply (UPS, option +G307)	128
Connecting the emergency stop push buttons (options +Q951, +Q952, +Q963, +Q964, +Q978,+Q979)	128
Wiring the starter for auxiliary motor fan (options +M6xx)	128
Wiring the PTC thermistor relay(s) (options +L505, +2L505, +L513 and +2L513)	128
Wiring the Pt100 relays (option +nL506)	129
Wiring the Pt100 relays (option +nL514)	130
Powering the heating and lighting equipment (options +G300, +G301 and +G313)	131
Wiring ground fault monitoring for IT ungrounded systems (option +Q954)	132
Setting the voltage range of the auxiliary control voltage transformer (T21)	132
Connecting a PC	133
Panel bus (Control of several units from one control panel)	133
Installing option modules	136
Installing option modules	136
Installation of an FSO-xx safety functions module beside the ZCU-12 control unit	137
Installation of an FSO-xx safety functions module onto ZCU-14	138
Safety functions module FSO-xx beside the ZCU-14 control unit	139
7 Control units of the drive	
Contents of this chapter	141
General	141
ZCU-12 layout	142
ZCU-14 layout	143
Default I/O diagram of the drive control unit (ZCU-1x)	144



Additional information on the connections	146
External power supply for the control unit (XPOW)	146
DI6 as a PTC sensor input	146
AI1 or AI2 as a Pt100, Pt1000, PTC or KTY84 sensor input	146
DIIL input	147
The XD2D connector	147
Safe torque off (XSTO)	148
FSO-xx safety functions module connection (X12)	148
Connector data	149
ZCU-1x ground isolation diagram	151

8 Installation checklist

Contents of this chapter	153
Checklist	153

9 Start-up

Contents of this chapter	155
Start-up procedure	155

10 Fault tracing

Contents of this chapter	159
LEDs	159
Warning and fault messages	159

11 Maintenance

Contents of this chapter	161
Maintenance intervals	161
Descriptions of symbols	161
Recommended annual maintenance actions by the user	161
Recommended maintenance intervals after start-up	162
Cabinet	163
Cleaning the interior of the cabinet	163
Cleaning the door air inlets (IP22 and IP42)	163
Replacing the inlet door filters (IP54)	164
Cleaning the roof outlet filters (IP54)	164
Replacing the outlet (roof) filters (IP54)	164
Cleaning the heatsink	165
Fans	165
Replacing cooling fans	165
Replacing the cabinet "door" fans	166
Replacing the cabinet fans (frames R6 to R9)	167
Replacing the drive module main fans (frames R6 to R8)	168
Replacing the auxiliary cooling fan of the drive module (frames R6 to R9)	169
Replacing the drive module main fans (frame R9)	170
Replacing the drive module main fans (frames R10 and R11)	171
Replacing the circuit board compartment cooling fan (frames R10 and R11)	172
Replacing the IP54 (UL type 12) roof fan of frames R6 to R8	173
Replacing the IP54 (UL type 12) roof fan of frame R9	174
Replacing the IP54 (UL type 12) roof fan of frames R10 and R11	175
Replacing the NSIN sine filter cooling fan	175
Replacing the drive module (frames R6 to R8)	176



Replacing the drive module (frame R9)	181
Replacing the drive module (frames R10 and R11)	185
Capacitors	192
Reforming the capacitors	192
Control panel	192
Cleaning the control panel	192
Replacing the battery	192
ZCU-12 control unit	193
Replacing the memory unit of ZCU-12	193
Replacing the ZCU-12 control unit battery	194
ZCU-14 control unit	194
Replacing the memory unit of ZCU-14	194
Replacing the ZCU-14 control unit battery	195
Replacing safety functions modules (FSO-12, option +Q973 and FSO-21, option +Q972)	196

12 Technical data

Contents of this chapter	197
Ratings	197
Definitions	200
Derating	201
Ambient temperature derating	201
Altitude derating	201
Switching frequency derating	202
Deratings for special settings in the drive control program	202
High speed mode	204
Fuses (IEC)	207
Fuses (UL)	209
Dimensions and weights	210
Dimensions and weights of sine filter cubicle (option +E206)	210
Free space requirements	211
Losses, cooling data and noise	211
Cooling data and noise for drives with sine filter (option +E206)	213
Typical power cable sizes	214
Terminal and entry data for the power cables	216
IEC	216
US	216
Terminal data for the control cables	223
Electrical power network specification	224
Motor connection data	224
Control unit connection data	225
Efficiency	225
Protection classes	225
Ambient conditions	225
Auxiliary circuit power consumption	226
Materials	226
Cabinet	226
Package	227
Disposal	227
Applicable standards	228
Markings	228



CE marking	229
Compliance with the European Low Voltage Directive	229
Compliance with the European EMC Directive	229
Compliance with the EN 61800-3:2004	230
Definitions	230
Category C2	230
Category C3	230
Category C4	231
UL and CSA checklist	232
Tightening torques	232
Electrical connections	233
Mechanical connections	233
Insulation supports	233
Cable lugs	233
Disclaimers	233
Generic disclaimer	233
Cybersecurity disclaimer	234

13 Dimension drawings

Frames R6 to R8 (IP22, IP42 [+B054], UL Type 1) – with and without options +C129, +H350, +H352	236
Frames R6 to R8 (IP54 / UL Type 12 [+B055]) – with and without options +C129, +H350, +H352	237
Frame R9 (IP22 and IP42 [+B054], UL Type 1) – with and without options +C129, +H350, +H352	238
Frame R9 (IP54 / UL Type 12 [+B055]) – with and without options +C129, +H350, +H352	239
Frame R9 marine (IP22, IP42 [+B054], UL Type 1) – option +C121)	240
Frames R6 to R8 with options +F289, +C129 with and without +H350, +H352 (UL Type 1)	241
Frames R6 to R8 with options +F289, +C129, with and without +H350, +H352 (UL Type 12 [+B055])	242
Frames R10 and R11 (IP22, IP42 [+B054], UL Type 1) – with and without options +C129, +H350, +H352	243
Frames R10 and R11 (IP54 / UL Type 12) – with and without options +C129, +H350, +H352	244

14 The Safe torque off function

Contents of this chapter	245
Description	245
Compliance with the European Machinery Directive	246
Wiring	247
Activation switch	247
Cable types and lengths	247
Grounding of protective shields	247
Single ACS880-07 drive, internal power supply	248
Dual-channel connection	248
Single-channel connection	248
Multiple drives	249
Internal power supply	249
External power supply	250

Operation principle	251
Start-up including validation test	252
Competence	252
Validation test reports	252
Validation test procedure	252
Use	254
Maintenance	255
Competence	255
Fault tracing	256
Safety data	257
Abbreviations	258
TÜV certificate	259
Declaration of conformity	259

15 Resistor braking

Contents of this chapter	261
When is resistor braking necessary?	261
Operation principle and hardware description	261
Planning the braking system	262
Selecting the brake circuit components	262
Selecting the default brake system components	262
Selecting a custom brake resistor	262
Selecting and routing the cables of custom resistors	263
Placing the brake resistor	264
Protecting the system against thermal overload	264
Protecting the brake resistor cable against short-circuits	265
Mechanical installation of custom brake resistors	265
Electrical installation of custom brake resistors	265
Measuring the insulation of the custom brake resistor circuit	265
Start-up	265
Parameter settings	265
Technical data	266
Ratings	266
Degree of protection of SAFUR resistors	268
Terminals and cable entry data	268

Further information



1

Safety instructions



Contents of this chapter

This chapter contains the safety instructions which you must obey when you install, start up, operate and do maintenance work on the drive. If you ignore the safety instructions, injury, death or damage can occur.

Use of warnings and notes

Warnings tell you about conditions which can cause injury or death, or damage to the equipment. They also tell you how to prevent the danger. Notes draw attention to a particular condition or fact, or give information on a subject.

The manual uses these warning symbols:

**WARNING!**

Electricity warning tells about hazards from electricity which can cause injury or death, or damage to the equipment.

**WARNING!**

General warning tells about conditions, other than those caused by electricity, which can cause injury or death, or damage to the equipment.

**WARNING!**

Electrostatic sensitive devices warning tells you about the risk of electrostatic discharge which can cause damage to the equipment.

General safety in installation, start-up and maintenance

These instructions are for all personnel who do work on the drive.



WARNING!

Obey these instructions. If you ignore them, injury or death, or damage to the equipment can occur.

- Keep the drive in its package until you install it. After unpacking, protect the drive from dust, debris and moisture.
- Use the required personal protective equipment: safety shoes with metal toe cap, safety glasses, protective gloves and long sleeves, etc. Some parts have sharp edges.
- Lift a heavy drive with a lifting device. Use the designated lifting points. See the dimension drawings.
- Incorrect lifting can cause danger or damage. Obey the local laws and regulations applicable to lifting, such as requirements for planning the lift, for capacity and condition of lifting equipment, and for training of personnel.
- Attach the drive cabinet to the floor to prevent it from toppling over. The cabinet has a high center of gravity. When you pull out heavy components or power modules, there is a risk of overturning. Attach the cabinet also to the wall when necessary.



- Do not stand or walk on the cabinet roof. Make sure that nothing presses against the roof, side or back plates or door. Do not store anything on the roof while the drive is in operation.
- Beware of hot surfaces. Some parts, such as heatsinks of power semiconductors, and brake resistors, remain hot for a while after disconnection of the electrical supply.
- Vacuum clean the area around the drive before the start-up to prevent the drive cooling fan from drawing the dust inside the drive.
- Make sure that debris from drilling, cutting and grinding does not enter the drive during the installation. Electrically conductive debris inside the drive may cause damage or malfunction.
- Make sure that there is sufficient cooling. See the technical data.
- Keep the cabinet doors closed when the drive is powered. With the doors open, a risk of a potentially fatal electric shock, arc flash or high-energy arc blast exists. If you cannot avoid working on a powered drive, obey the local laws and regulations on live working (including – but not limited to – electric shock and arc protection).

- Before you adjust the drive operation limits, make sure that the motor and all driven equipment can operate throughout the set operation limits.
- Before you activate the automatic fault reset or automatic restart functions of the drive control program, make sure that no dangerous situations can occur. These functions reset the drive automatically and continue operation after a fault or supply break. If these functions are activated, the installation must be clearly marked as defined in IEC/EN 61800-5-1, subclause 6.5.3, for example, "THIS MACHINE STARTS AUTOMATICALLY".
- The maximum drive power cycles is five times in ten minutes. Power cycling the drive too often can damage the charging circuit of the DC capacitors.
- If you have connected safety circuits to the drive (for example, Safe torque off or emergency stop), validate them at start-up. See separate instructions for the safety circuits.
- Beware of hot air exiting from the air outlets.
- Do not cover the air inlet or outlet when the drive is running.

Note:

- If you select an external source for the start command and it is on, the drive will start immediately after fault reset unless you configure the drive for pulse start. See the firmware manual.
- If the drive is in remote control mode, you cannot stop or start the drive with the control panel.
- Only authorized persons are allowed to repair a malfunctioning drive.



Electrical safety in installation, start-up and maintenance

■ Electrical safety precautions

These electrical safety precautions are for all personnel who do work on the drive, motor cable or motor.



WARNING!

Obey these instructions. If you ignore them, injury or death, or damage to the equipment can occur.

If you are not a qualified electrical professional, do not do installation or maintenance work.

Go through these steps before you begin any installation or maintenance work.

1. Clearly identify the work location and equipment.
2. Disconnect all possible voltage sources. Make sure that re-connection is not possible. Lock out and tag out.
 - Open the main disconnecting device of the drive.
 - Open the charging switch if present.
 - Open the disconnecter of the supply transformer. (The main disconnecting device in the drive cabinet does not disconnect the voltage from the AC input power busbars of the drive cabinet.)
 - Open the auxiliary voltage switch-disconnector (if present), and all other possible disconnecting devices that isolate the drive from dangerous voltage sources.
 - If you have a permanent magnet motor connected to the drive, disconnect the motor from the drive with a safety switch or by other means.
 - Disconnect all dangerous external voltages from the control circuits.
 - After you disconnect power from the drive, always wait 5 minutes to let the intermediate circuit capacitors discharge before you continue.
3. Protect any other energized parts in the work location against contact.
4. Take special precautions when close to bare conductors.



5. Measure that the installation is de-energized. If the measurement requires removal or disassembly of shrouding or other cabinet structures, obey the local laws and regulations applicable to live working (including – but not limited to – electric shock and arc protection).

- Before and after measuring the installation, verify the operation of the voltage tester on a known voltage source.
- Make sure that the voltage between the drive input power terminals (L1, L2, L3) and the grounding (PE) busbar is zero.

Measuring holes of the standard drive are shown below.

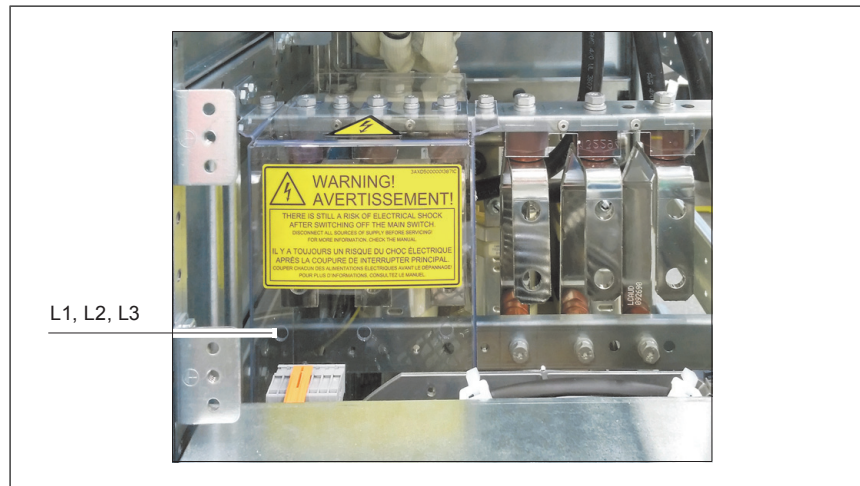

- Make sure that the voltage between the drive output terminals (T1/U, T2/V, T3/W) and the grounding (PE) busbar is zero.
- Make sure that the voltage between the drive DC terminals (UDC+ and UDC-) and the grounding (PE) terminal is zero.

6. Install temporary grounding as required by the local regulations.

7. Ask the person in control of the electrical installation work for a permit to work.

■ Additional instructions and notes



WARNING!

Obey these instructions. If you ignore them, injury or death, or damage to the equipment can occur.

If you are not a qualified electrical professional, do not do installation or maintenance work.

- Keep the cabinet doors closed when the drive is powered. With the doors open, a risk of a potentially fatal electric shock, arc flash or high-energy arc blast exists.
- Make sure that the electrical power network, motor/generator, and environmental conditions agree with the drive data.
- Do not do insulation or voltage withstand tests on the drive.

- If you have a cardiac pacemaker or other electronic medical device, keep away from the area near motor, drive, and the drive power cabling when the drive is in operation. There are electromagnetic fields present which can interfere with the function of such devices. This can cause a health hazard.
- ABB recommends against attaching the cabinet by arc welding. If you have to, obey the welding instructions in the drive manuals.

Note:

- The motor cable terminals of the drive are at a dangerous voltage when the input power is on, regardless of whether the motor is running or not.
- When the input power is on, the drive DC bus is at a dangerous voltage. If brake chopper and resistor are in use, they are at a dangerous voltage. (Option +D150) (Option +D151).
- External wiring can supply dangerous voltages to the relay outputs of the control units of the drive.
- The Safe torque off function does not remove the voltage from the main and auxiliary circuits. The function is not effective against deliberate sabotage or misuse.

Optical components



WARNING!

Obey these instructions. If you ignore them, damage to the equipment can occur.

- Handle the fiber optic cables with care.
- When you unplug the fiber optic cables, always hold the connector, not the cable itself.
- Do not touch the ends of the fibers with bare hands as the ends are extremely sensitive to dirt.
- Do not bend the fiber optic cables too tightly. The minimum allowed bend radius is 35 mm (1.4 in).

Printed circuit boards



WARNING!

Use a grounding wrist band when you handle printed circuit boards. Do not touch the boards unnecessarily. The boards contain components sensitive to electrostatic discharge.

■ **Grounding**

These instructions are for all personnel who are responsible for the grounding of the drive.



WARNING!

Obey these instructions. If you ignore them, injury or death, or equipment malfunction can occur, and electromagnetic interference can increase.

If you are not a qualified electrical professional, do not do grounding work.

- Always ground the drive, the motor and adjoining equipment. This is necessary for the personnel safety. Proper grounding also reduces electromagnetic emission and interference.
- Make sure that the conductivity of the protective earth (PE) conductors is sufficient. See the electrical planning instructions of the drive. Obey the local regulations.
- Connect the power cable shields to protective earth (PE) terminals of the drive to make sure of personnel safety.
- Make a 360° grounding of the power and control cable shields at the cable entries to suppress electromagnetic disturbances.
- In a multiple-drive installation, connect each drive separately to the protective earth (PE) busbar of the power supply.

Note:

- You can use power cable shields as grounding conductors only when their conductivity is sufficient.
- As the normal touch current of the drive is higher than 3.5 mA AC or 10 mA DC, you must use a fixed protective earth (PE) connection. The minimum size of the protective earth conductor must comply with the local safety regulations for high protective earth conductor current equipment. See standard IEC/EN 61800-5-1 (UL 61800-5-1) and the electrical planning instructions of the drive.



General safety in operation

These instructions are for all personnel that operate the drive.



WARNING!

Obey these instructions. If you ignore them, injury or death, or damage to the equipment can occur.

- Keep the cabinet doors closed when the drive is powered. With the doors open, a risk of a potentially fatal electric shock, arc flash or high-energy arc blast exists.
- If you have a cardiac pacemaker or other electronic medical device, keep away from the area near motor, drive, and the drive power cabling when the drive is in operation. There are electromagnetic fields present which can interfere with the function of such devices. This can cause a health hazard.
- Give a stop command to the drive before you reset a fault. If you have an external source for the start command and the start is on, the drive will start immediately after the fault reset, unless you configure the drive for pulse start. See the firmware manual.
- Before you activate the automatic fault reset or automatic restart functions of the drive control program, make sure that no dangerous situations can occur. These functions reset the drive automatically and continue operation after a fault or supply break. If these functions are activated, the installation must be clearly marked as defined in IEC/EN 61800-5-1, subclause 6.5.3, for example, "THIS MACHINE STARTS AUTOMATICALLY".

Note:

- The maximum drive power cycles is five times in ten minutes. Power cycling the drive too often can damage the charging circuit of the DC capacitors. If you need to start or stop the drive, use the control panel keys or commands through the I/O terminals of the drive.
- If the drive is in remote control mode, you cannot stop or start the drive with the control panel.

Additional instructions for permanent magnet motor drives

■ **Safety in installation, start-up, maintenance**

These are additional warnings concerning permanent magnet motor drives. The other safety instructions in this chapter are also valid.



WARNING!

Obey these instructions. If you ignore them, injury or death, or damage to the equipment can occur.

If you are not a qualified electrical professional, do not do installation or maintenance work.

- Do not do work on the drive when a rotating permanent magnet motor is connected to it. A rotating permanent magnet motor energizes the drive including its input and output power terminals.

Before installation, start-up and maintenance work on the drive:

- Stop the drive.
- Disconnect the motor from the drive with a safety switch or by other means.
- If you cannot disconnect the motor, make sure that the motor cannot rotate during work. Make sure that no other system, like hydraulic crawling drives, can rotate the motor directly or through any mechanical connection like felt, nip, rope, etc.
- Do the steps in section [Electrical safety precautions \(page 18\)](#).
- Install temporary grounding to the drive output terminals (T1/U, T2/V, T3/W). Connect the output terminals together as well as to the PE.

During the start up:

- Make sure that the motor cannot run overspeed, for example, driven by the load. Motor overspeed causes overvoltage that can damage or destroy the capacitors in the intermediate circuit of the drive.

■ Safety in operation



WARNING!

Make sure that the motor cannot run overspeed, for example, driven by the load. Motor overspeed causes overvoltage that can damage or destroy the capacitors in the intermediate circuit of the drive.



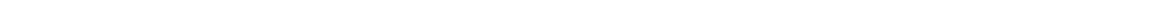

2

Introduction to the manual

Contents of this chapter

This chapter describes the manual. It contains a flowchart of steps in checking the delivery, installing and starting up the drive. The flowchart refers to chapters/sections in this manual and to other manuals.

Target audience

This manual is intended for people who plan the installation, install, start up and do maintenance work on the drive, or create instructions for the end user of the drive concerning the installation and maintenance of the drive.

Read the manual before working on the drive. You are expected to know the fundamentals of electricity, wiring, electrical components and electrical schematic symbols.

Categorization by frame size and option code

The frame size identifies information which concerns only a certain frame size of the drive. The frame size is shown on the type designation label. All frame sizes are listed in the technical data.

The option code (+A123) identifies information which concerns only a certain optional selection. The options included in the drive are listed on the type designation label.

Quick installation, commissioning and operation flowchart

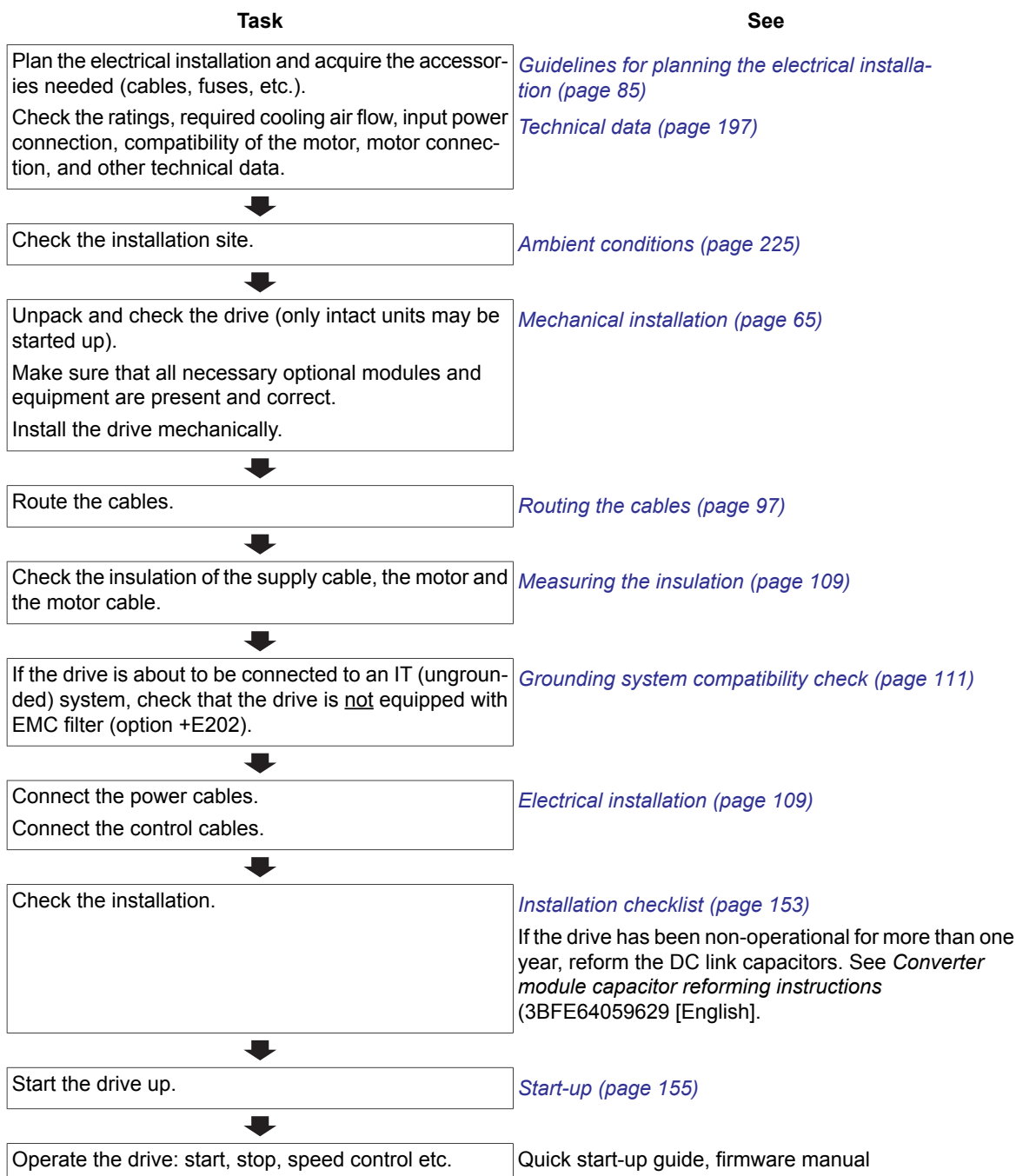

Terms and abbreviations

Term	Description
ACS-AP-I	Industrial assistant non-Bluetooth control panel
ACS-AP-W	Industrial assistant control panel with Bluetooth interface
CMF	Common mode filtering
DDCS	Distributed drives communication system protocol
Drive	Frequency converter for controlling AC motors
DTC	Direct torque control, a motor control method
EMC	Electromagnetic compatibility

Term	Description
EMI	Electromagnetic interference
FAIO-01	Optional analog I/O extension module
FCAN-01	Optional CANopen® adapter module
FCNA-01	Optional ControlNet™ adapter module
FDCO-01	DDCS communication module with two pairs of 10 Mbit/s DDCS channels
FDCO-02	DDCS communication module with one pair of 10 Mbit/s and one pair of 5 Mbit/s DDCS channels
FDIO-01	Optional digital I/O extension module
FDNA-01	Optional DeviceNet™ adapter module
FEA-03	Optional I/O extension adapter
FECA-01	Optional EtherCAT® adapter module
FEIP-21	Optional Ethernet adapter module
FEN-01	Optional TTL incremental encoder interface module
FEN-11	Optional TTL absolute encoder interface module
FEN-21	Optional resolver interface module
FEN-31	Optional HTL incremental encoder interface module
FENA-21	Optional Ethernet adapter module for EtherNet/IP™, Modbus TCP® and PROFINET IO® protocols, 2-port
FEPL-02	Optional Ethernet POWERLINK adapter module
FIO-01	Optional digital I/O extension module
FIO-11	Optional analog I/O extension module
FMBT-21	Optional Ethernet adapter module for Modbus TCP protocol
FPBA-01	Optional PROFIBUS DP® adapter module
FPNO-21	Optional Profinet IO adapter module
FPTC-01	Optional thermistor protection module
FPTC-02	Optional ATEX-certified thermistor protection module for potentially explosive atmospheres
Frame, frame size	Physical size of the drive or power module
FSCA-01	Optional RS-485 (Modbus/RTU) adapter
FSO-21	Safety functions module which supports the FSE-31 module and the use of safety encoders
FSO-12	Safety functions module which does not support the use of encoders
FSPS-21	Optional functional safety module
HTL	High-threshold logic
IGBT	Insulated gate bipolar transistor
Inverter unit	Inverter module(s) under control of one control unit, and related components. One inverter unit typically controls one motor.
IT system	Type of supply network that has no (low-impedance) connection to ground. See IEC 60364-5.
MCCB	Molded case circuit breaker
PLC	Programmable logic controller
Power module	Common term for drive module, inverter module, supply module, brake chopper module etc.
RFI	Radio-frequency interference
SAFUR	Series of brake resistors
SAR	Safe acceleration range
SBC	Safe brake control
SLS	Safely-limited speed
SS1	Safe stop 1 (IEC/EN 61800-5-2)
SSE	Safe stop emergency
SSM	Safe speed monitor without encoder
STO	Safe torque off (IEC/EN 61800-5-2)

Term	Description
Supply unit	Supply module(s) under control of one control unit, and related components.
TN system	Type of supply network that provides a direct connection to ground
ZCU	Type of control unit
ZGAB	Brake chopper adapter board
ZGAD	Gate driver adapter board
ZINT	Main circuit board
ZMU	Type of memory unit, attached to the control unit

Related manuals

Name	Code (English/Multi-lingual)	Code (Translation)
Drive hardware manuals and guides		
<i>Drive/converter/inverter safety instructions</i>	3AXD50000037978	
<i>ACS880-07 drives (45 to 710, 50 to 700 hp) hardware manual</i>	3AUA0000105718	
<i>EMC filter and ground-to-phase varistor disconnecting instructions for ACS880 frames R1 to R11</i>	3AUA0000125152	
<i>ACx-AP-x assistant control panels user's manual</i>	3AUA0000085685	
<i>Converter module lifting device for drive cabinets</i>	3AXD50000210268	
Drive firmware manuals and guides		
<i>ACS880 primary control program firmware manual</i>	3AUA0000085967	
<i>Quick start-up guide for ACS880 drives with primary control program</i>	3AUA0000098062	
Option manuals and guides		
<i>Drive composer start-up and maintenance PC tool user's manual</i>	3AUA0000094606	
<i>FSO-12 safety functions module user's manual</i>	3AXD50000015612	
<i>FSO-21 safety functions module user's manual</i>	3AXD50000015614	
<i>User's manual for Prevention of unexpected start-up (+Q950) for ACS880-07/17/37 drives</i>	3AUA0000145922	
<i>User's manual for Emergency stop, stop category 0 (+Q951) for ACS880-07/17/37 drives</i>	3AUA0000119895	
<i>User's manual for Emergency stop, stop category 1 (+Q952) for ACS880-07/17/37 drives</i>	3AUA0000119896	
<i>User's manual for Prevention of unexpected start-up (+Q957) for ACS880-07/17/37 drives</i>	3AUA0000119910	
<i>User's manual for Emergency stop, stop category 0 (+Q963) for ACS880-07/17/37 drives</i>	3AUA0000119908	
<i>User's manual for Emergency stop, stop category 1 (+Q964) for ACS880-07/17/37 drives</i>	3AUA0000119909	
<i>User's manual for FPTC-02 ATEX-certified thermistor protection module, Ex II (2) GD (option +L537 +Q971) for ACS880 drives</i>	3AXD50000027782	
<i>User's manual for Emergency stop, configurable stop category 0 or 1 (+Q978) for ACS880-07/17/37 drives</i>	3AUA0000145920	
<i>User's manual for Emergency stop, configurable stop category 0 or 1 (+Q979) for ACS880-07/17/37 drives</i>	3AUA0000145921	
<i>Bypass connection for ACS880-07, -17, and -37 drives (40...1200 A) option description</i>	3AXD50000048959	

Name	Code (English/Multi-lingual)	Code (Translation)
<i>Manuals and quick guides for I/O extension modules, fieldbus adapter, etc.</i>		

The code below opens an online listing of the manuals applicable to the product:



[ACS880-07 \(45...400 kW, 60...450 hp\) manuals](#)

See www.abb.com/drives/documents for all manuals on the Internet.

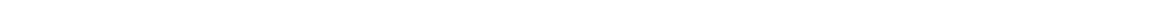



Operation principle and hardware description

Contents of this chapter



This chapter briefly describes the operation principle and construction of the drive.

Product overview

The ACS880-07 is an air-cooled cabinet-installed drive for controlling asynchronous AC induction motors, permanent magnet synchronous motors, AC induction servomotors and ABB synchronous reluctance motors (SynRM motors) with option N7502.

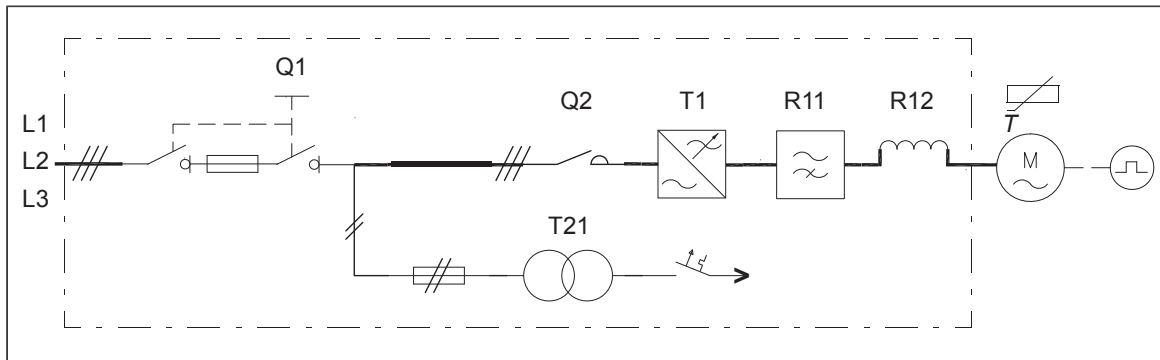
■ Single-line circuit diagram of the drive



Q1	Main switch-disconnector (switch fuse in frames R6 to R8, switch-disconnector and separate fuses in frames R9 to R11, or molded case circuit breaker and separate fuses [option +F289 for US market only])
Q2	Optional line contactor (+F250)
T21	Auxiliary voltage transformer. Supplies 230 V control voltage to, for example, cabinet fan(s) and to 24 V DC power supply for I/O extension adapter module.
T1	Drive module
R11	Optional common mode filter (+E208)
R12	Optional du/dt filter (+E205) or sine filter (+E206)
	HTL pulse encoder for optional FEN-31 HTL incremental encoder interface module (+L502)
	PTC sensors for optional thermistor relay(s) (+L505, +2L505) or Pt100 sensors for optional Pt100 relays (+xL506)

■ **Block diagram of the brake and DC options (+D150, +D151 and +H356)**

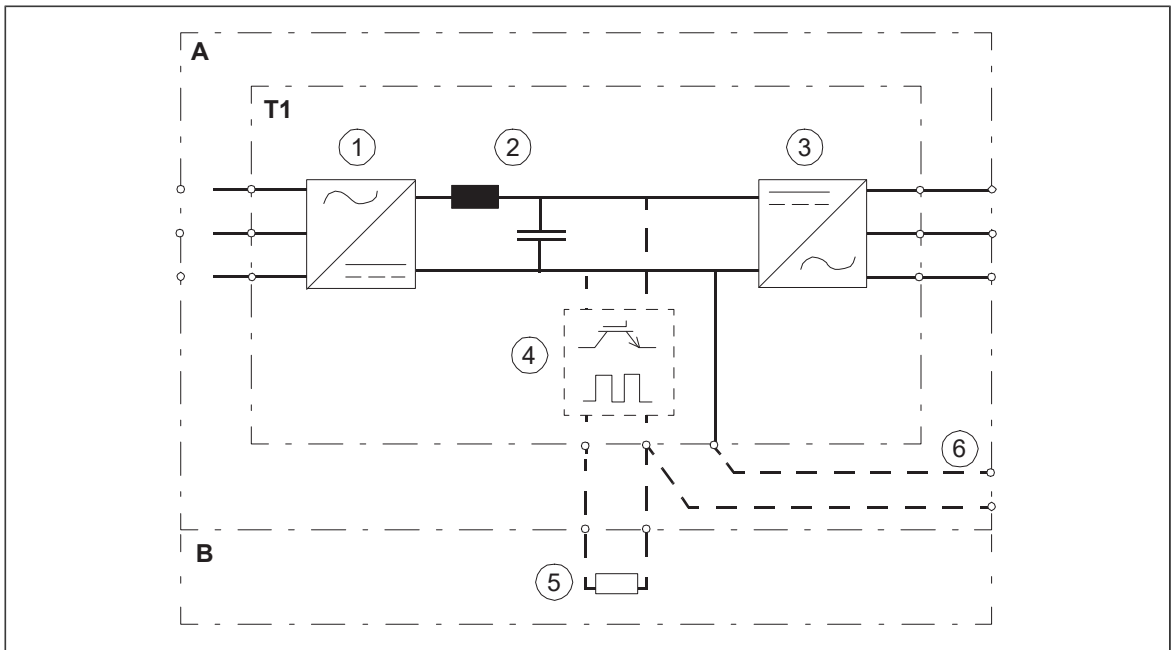

A	Drive module cubicle
T1	Drive module
B	Brake resistor cubicle
1	Rectifier. Converts alternating current and voltage to direct current and voltage.
2	DC link. DC circuit between rectifier and inverter. DC choke is included in frames R6 to R9. An AC input choke is included in frames R10 and R11.
3	Inverter. Converts direct current and voltage to alternating current and voltage.
4	Brake chopper (option +D150). Conducts the surplus energy from the intermediate DC circuit of the drive to the brake resistor when necessary. The chopper operates when the DC link voltage exceeds a certain maximum limit. The voltage rise is typically caused by deceleration (braking) of a high inertia motor. User obtains and installs the brake resistor when needed.
5	Brake resistor (option +D151)
6	Optional DC cable connection busbars (+H356). Not available with option +D150.

■ General information on the cabinet layout



IP22/IP42
UL Type 1/
UL Type 1 Filtered



IP54
UL Type 12



UL Type 1 with molded case circuit breaker (option +F289 for US market only)

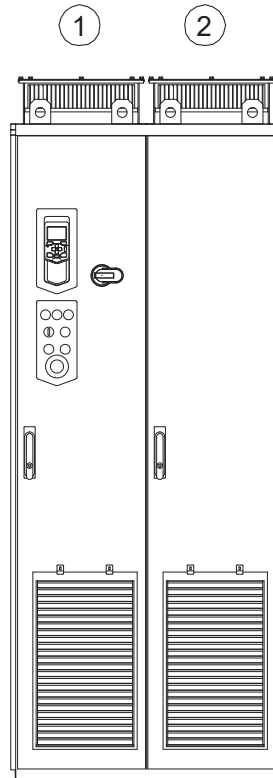

Example cabinet line-up

- | | |
|---|---|
| 1 | Frames R6 to R8: drive module cubicle.
Frames R9 to R11: two cubicles with one door (main switch and power cabling cubicle and drive module cubicle) |
| 2 | Brake resistor cubicle with option +D151 |

■ **Cabinet layout of frames R6 to R8**

The cabinet layout without shrouds is shown below.

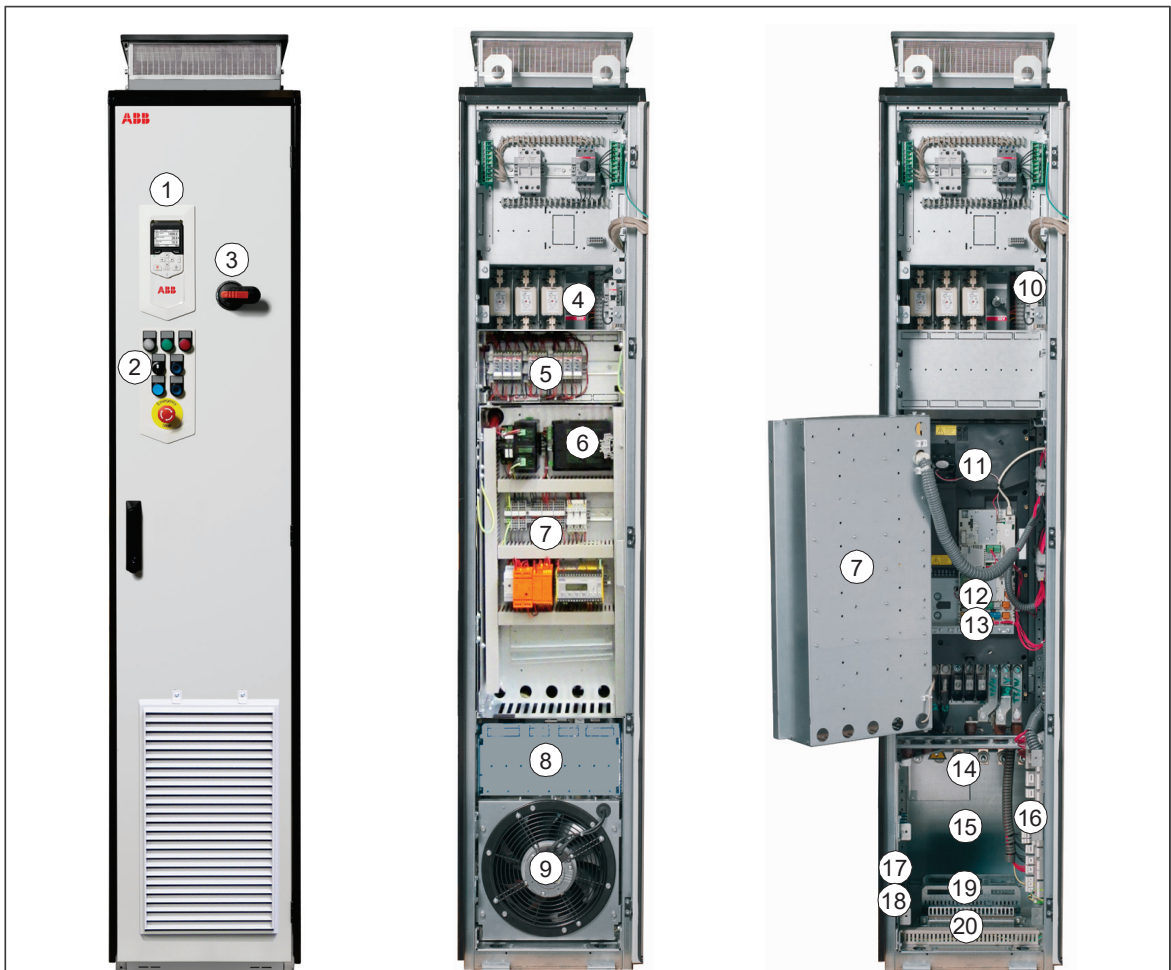

1	Drive control panel	11	Drive module
2	Door switches and lights	12	Control unit
3	Main switch handle	13	Optional terminal block for external control unit connections (X504, option +L504)
4	Main switch-disconnector with fuses	14	Power cable connection terminals and du/dt filter (option +E205) and common mode filter (option +E208) behind
5	Thermistor and Pt100 relays (options +L505 and +L506)	15	Common mode filter (option +E208)
6	Buffer module C22	16	Connection terminals for options +F250, +Q951, +Q952, +Q963, +Q964+Q968, +Q954, +M600...+M605, +L505, +L506
7	Swing-out frame	17	Cabinet heater (option +G300)
8	Mounting plate with connection terminals for options +G300, +G307, +G313 at the back side of the plate	18	PE busbar
9	“Door” fan	19	Power cable entries
10	Auxiliary voltage transformer (T21)	20	Control cable entry

■ **Cabinet layout of frames R6 to R8 with option +C129**

The cabinet layout without shrouds is shown below.



1	Drive control panel	11	Buffer module C22
2	Door switches and lights	12	Swing-out frame
3	Main switch handle	13	Mounting plate with connection terminals for options +G300, +G307, +G313 at the back side of the plate
4	Power and control cable entries	14	"Door" fan
5	Ground bar	15	Drive module
6	Input cable connection terminals	16	Control unit
7	Motor cable connection terminals	17	Optional terminal block for external control unit connections (X504, option +L504)
8	Auxiliary voltage transformer (T21)	18	Connection terminals for options +F250, +Q951, +Q952, +Q963, +Q964+Q968, +Q954, +M600...+M605, +L505, +L506
9	Main switch-disconnector with fuses	19	Cabinet heater (option +G300)
10	Thermistor and Pt100 relays (options +L505 and +L506)	-	-

■ **Cabinet layout of frames R6 to R8 with options +C129 and +F289**

Option +C129 +F289 is available for US market only. The cabinet layout without shrouds is shown below.



1	Drive control panel	8	Main fuses for control devices, IP54 fan transformer (with option +B055), V-meter (option +G334), starter for auxiliary motor fan (option +M600)
2	Door switches and lights,	9	Auxiliary voltage transformer (T21)
3	Main switch handle	10	Thermistor and Pt100 relays (options +L505 and +L506)
4	Input power cable entries	11	Buffer module C22
5	Ground bar	12	Swing-out frame
6	Input power cable terminals	13	Mounting plate with connection terminals for options +G300, +G307, +G313 at the back side of the plate
7	Molded case circuit breaker (option +F289)	14	"Door" fan

38 Operation principle and hardware description



15	Control cable entries	20	Control unit
16	Motor cable entries	21	Optional terminal block for external control unit connections (X504, option +L504)
17	Ground bar	22	Common mode filter (option +E208)
18	Motor cable connection terminals	23	Connection terminals for options +F250, +Q951, +Q952, +Q963, +Q964+Q968, +Q954, +M600...+M605,+ L505, +L506.
19	Drive module	24	Cabinet heater (option +G300)

■ **Cabinet layout of frame R9**

The cabinet layout is shown below. See also the next page.



A - Main breaker and power cabling cubicle		B - Drive module cubicle	
1	Drive control panel	9	Buffer module
2	Operating switch	10	Swing-out frame
3	Main switch handle	11	Thermistor and Pt100 relays (options +L505 and +L506)
4	Motor cable connection terminals	12	Mounting plate with connection terminals for options +G300, +G301, +G307, +G313 at the back side of the plate
5	du/dt filter (option +E205)	-	-
6	Input cable connection terminals	-	-
7	Main switch-disconnector	-	-
8	AC fuses	-	-

40 Operation principle and hardware description

The cabinet layout without shrouds, with the swing-out frame open is shown below.

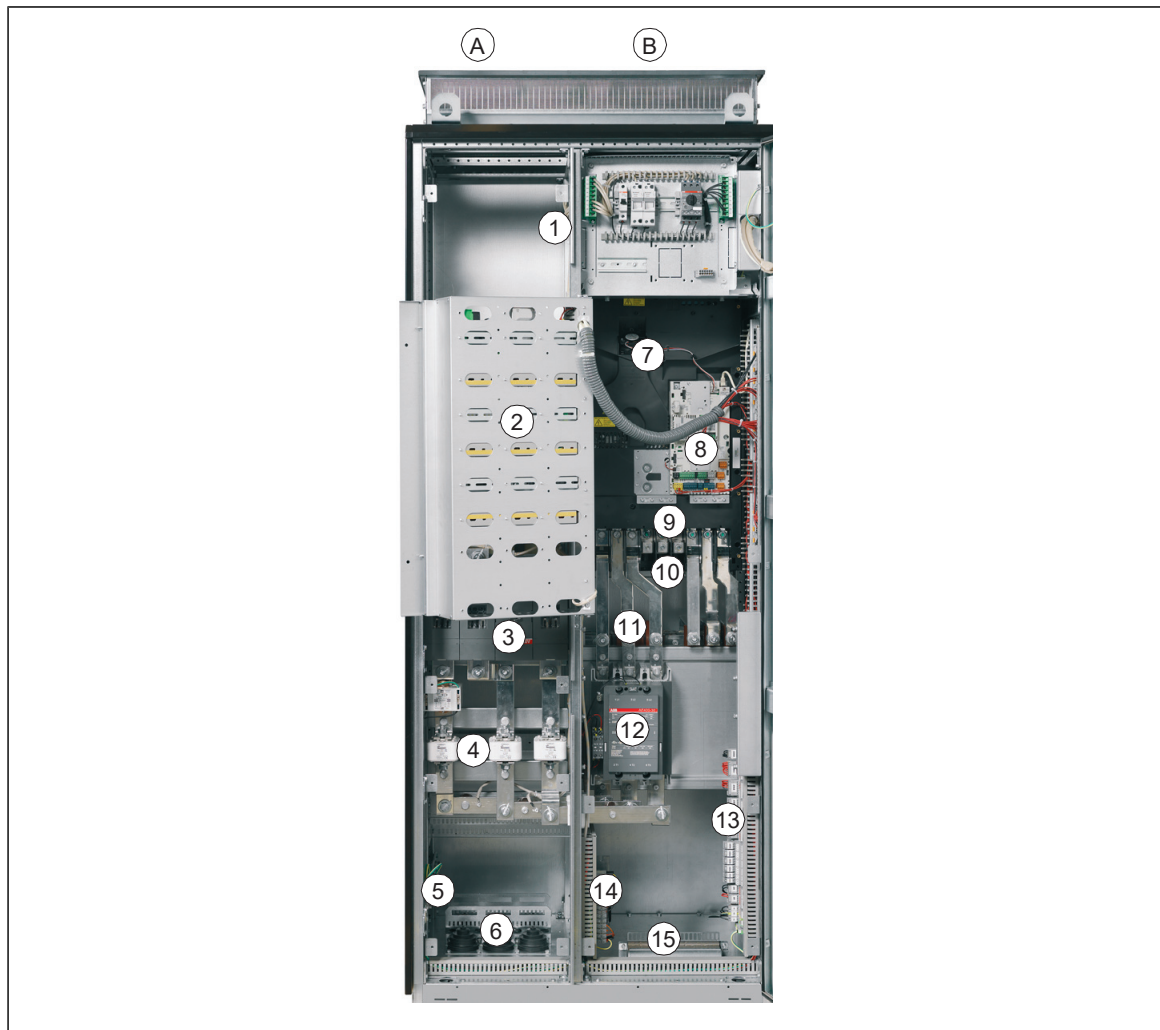

A - Main breaker and power cabling cubicle		B - Drive module cubicle	
1	Auxiliary voltage transformer (T21)	7	Drive module
2	Swing-out frame	8	Control unit
3	Main switch-disconnector or molded case circuit breaker with option +F289	9	Optional terminal block for external control unit connections (X504, option +L504)
4	AC fuses	10	Connection terminals for external brake resistor and DC cables
5	PE-terminal	11	Common mode filter (option +E208) behind the busbars
6	Power cable entries	12	Line contactor (option +F250)
-	-	13	Connection terminals for options +F250, +Q951, +Q952, +Q963, +Q964+Q968, +Q954, +M600...+M605,+ L505, +L506
-	-	14	Cabinet heater (option +G300)
-	-	15	Control cable entry

■ **Cabinet layout of frame R9 with options +C129 and +F289**

The cabinet layout is shown below. See also the next page.



A - Main breaker and power cabling cubicle		B - Drive module cubicle	
1	Drive control panel	10	Buffer module
2	Operating switch	11	Swing-out frame
3	Main switch handle	12	Thermistor and Pt100 relays (options +L505 and +L506)
4	Power cable entries	13	Mounting plate with connection terminals for options +G300, +G301, +G307, +G313 at the back side of the plate
5	Input cable connection terminals	-	-
6	Motor cable connection terminals	-	-
7	Ground bar	-	-
8	Molded case circuit breaker (option +F289)	-	-
9	AC fuses	-	-

42 Operation principle and hardware description

The cabinet layout with the swing-out frame open is shown below.



1	Control cable entry	7	Connection terminals for external brake resistor and DC cables
2	Swing-out frame	8	Line contactor (option +F250)
3	Drive module	9	Connection terminals for options +F250, +Q951, +Q952, +Q963, +Q964+Q968, +Q954, +M600...+M605, +L505, +L506.
4	Control unit	10	Cabinet heater (option +G300)
5	Optional terminal block for external control unit connections (X504, option +L504)	11	Auxiliary voltage transformer (T21)
6	Common mode filter (option +E208) behind the busbars	-	-

■ **Cabinet layout of frames R10 and R11 – bottom entry and exit of cables**

The cabinet layout is shown below. See also the next page.

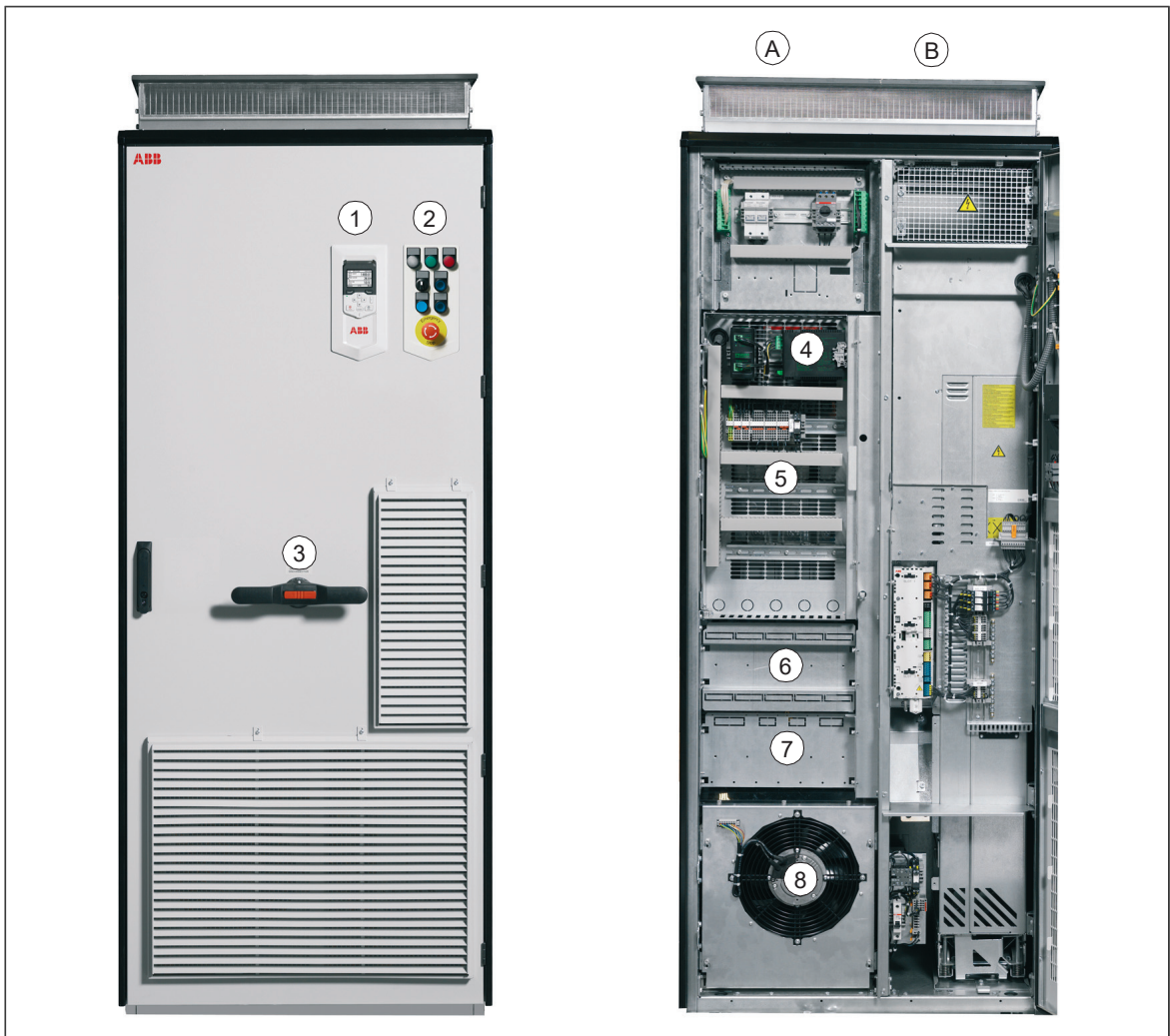

A – Main breaker and power cabling cubicle		B - Drive module cubicle	
1	Drive control panel	-	See the next page.
2	Operating switch	-	-
3	Main switch handle	-	-
4	Buffer module	-	-
5	Swing-out frame	-	-
6	Thermistor and Pt100 relays (options +L505 and +L506)	-	-
7	Mounting plate with connection terminals for options +G300, +G301, +G307, +G313 at the back side of the plate	-	-
8	“Door” fan	-	-

The cabinet layout without shrouds, with the swing-out frame open is shown below.

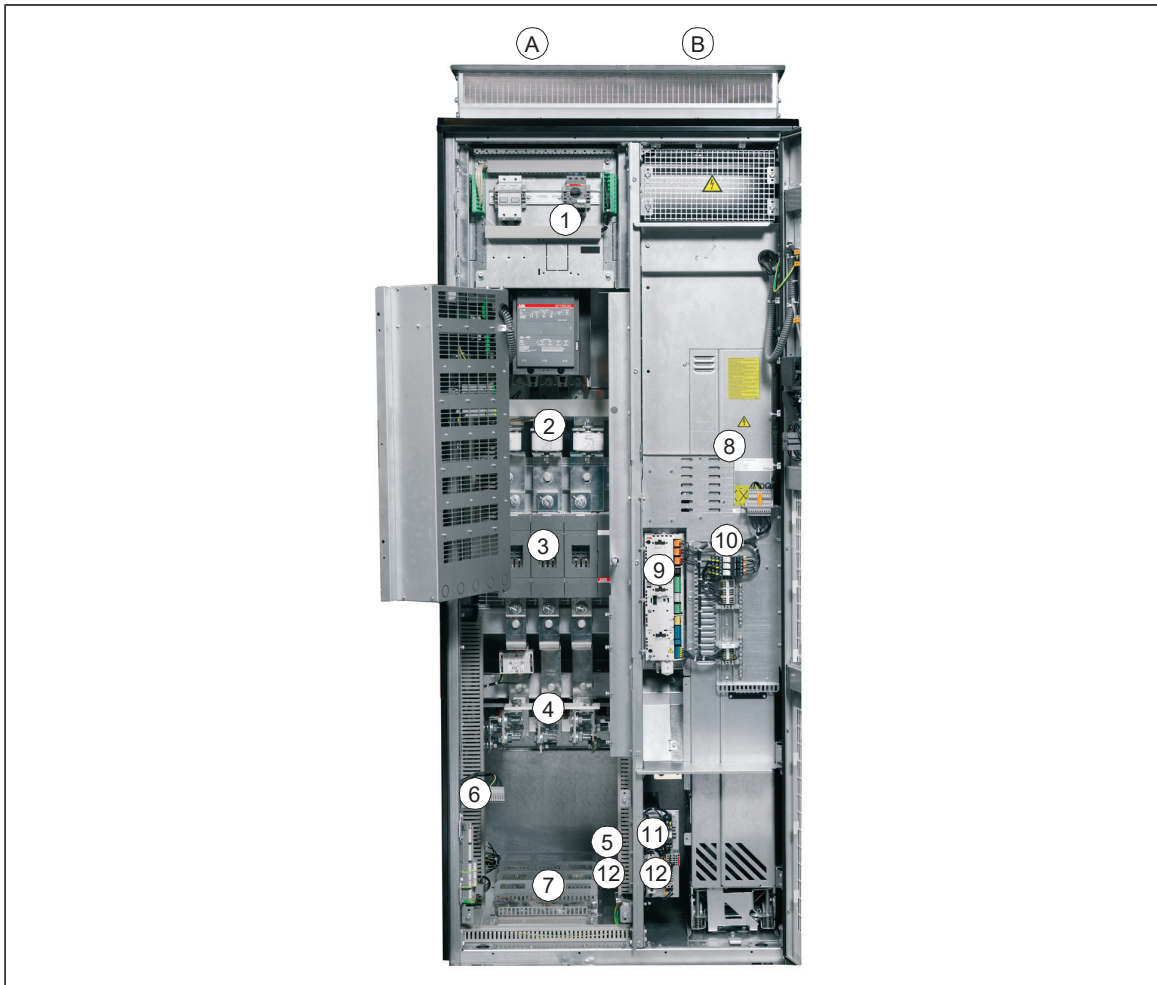

A – Main breaker and power cabling cubicle		B - Drive module cubicle	
1	Main fuses for control devices, IP54 fan transformer (with option +B055), V-meter (option +G334), starter for auxiliary motor fan (option +M600)	8	Drive module
2	AC fuses	9	Control unit
3	Main switch-disconnector	10	Optional terminal block for external control unit connections (X504, option +L504)
4	Input and motor cable connection terminals	11	Auxiliary voltage transformer (T21)
5	PE-terminal	12	Cabinet heater
6	Connection terminals for options +F250, +Q951, +Q952, +Q963, +Q964+Q968, +Q954, +M600...+M605,+ L505, +L506.	-	-
7	Power and control cable entries	-	-

■ **Cabinet layout of frames R10 and R11 – top entry and exit of cables (option +C129)**

The cabinet layout is shown below.



A – Main breaker and power cabling cubicle		B - Drive module cubicle	
1	Main fuses for control devises, IP54 fan transformer (with option +B055), V-meter (option +G334), starter for auxiliary motor fan (option +M600)	8	Drive module
2	AC fuses	9	Control unit
3	Main switch-disconnector	10	Optional terminal block for external control unit connections (X504, option +L504)
4	Input and motor cable connection terminals	11	Auxiliary voltage transformer (T21)
5	PE-terminal	12	Cabinet heater
6	Power and control cable entries	-	-
7	“Door” fan	-	-

■ Overview of power and control connections

The diagram shows the power connections and control interfaces of the drive.

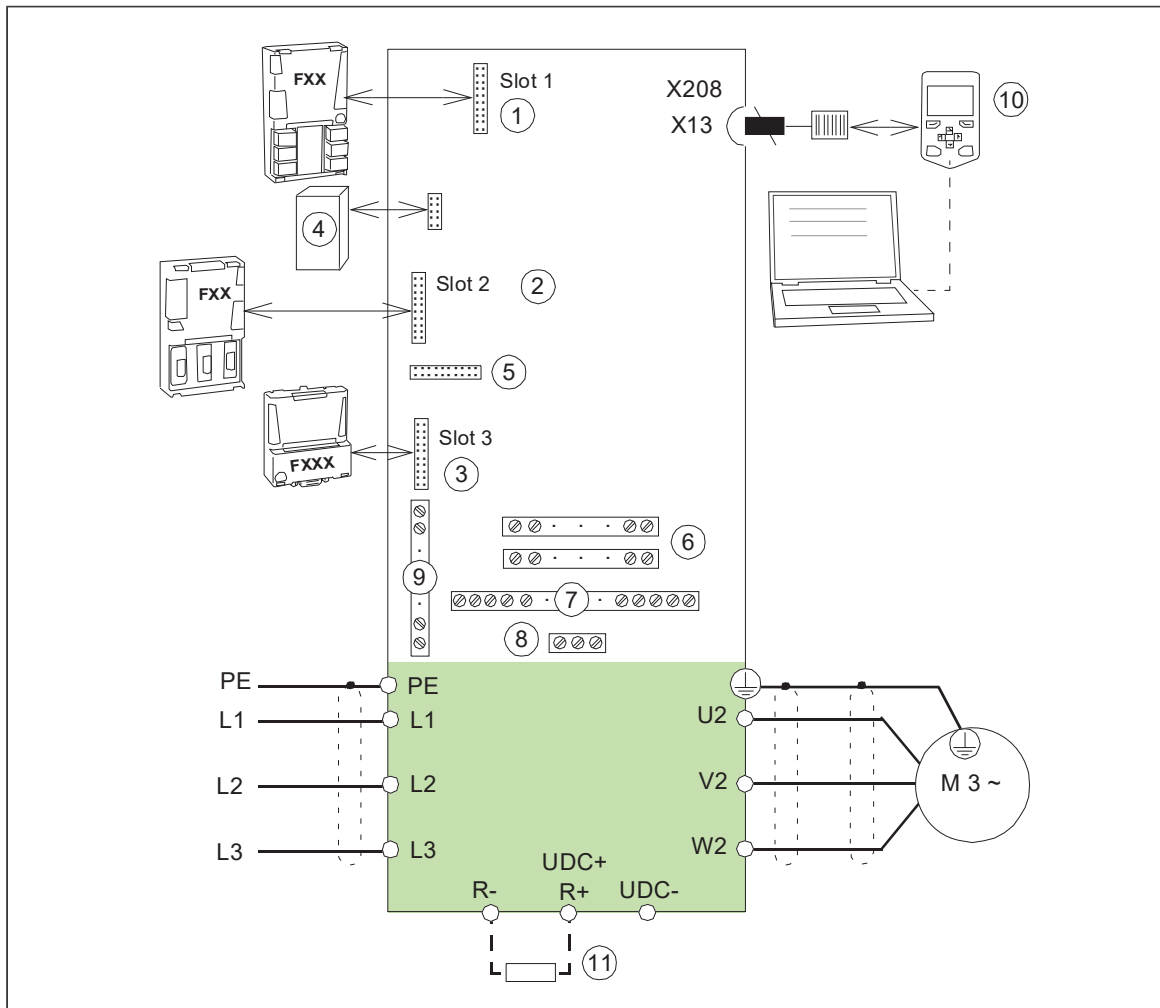

1	Analog and digital I/O extension modules, feedback interface modules and fieldbus communication modules can be inserted into slots 1, 2 and 3. See section Type designation key (page 59) .
2	
3	
4	Memory unit
5	Connector for safety functions module
6	See chapter Control units of the drive (page 141)
7	Additional terminal block X504 for control cable connections to the control unit (option +L504)
8	Connection terminals for options +G300, +G307, +G313
9	Connection terminals for options
10	See section Control panel (page 49)
11	External brake resistor with brake chopper option (+D150) if brake resistor option +D151 is not selected.

The layout of external control connection terminals at the side of the drive cabinet is shown below. The composition depends on the options selected.

<p>The image shows two vertical terminal block diagrams. The left diagram has terminals labeled X965 (top), X969, X951, X954, X601, X506, X250, and X957. The right diagram has terminals labeled X965, X969, X289, X951, X954, X601, X506, X250, and X957. Each terminal block shows a grid of terminals with some terminals highlighted in red or green, indicating specific connection points.</p>	<table border="1"> <thead> <tr> <th data-bbox="815 219 930 271"></th> <th data-bbox="930 219 1455 271">Terminals for</th> </tr> </thead> <tbody> <tr> <td data-bbox="815 271 930 360">X250</td> <td data-bbox="930 271 1455 360">Auxiliary contacts of optional line contactor (+F250)</td> </tr> <tr> <td data-bbox="815 360 930 439">X289</td> <td data-bbox="930 360 1455 439">Auxiliary contacts of optional molded case circuit breaker (MCCB) (+F289)</td> </tr> <tr> <td data-bbox="815 439 930 607">X951, X952, X963 or X964</td> <td data-bbox="930 439 1455 607">Push buttons for emergency stop options +Q951, +Q952, +Q963 and +Q964</td> </tr> <tr> <td data-bbox="815 607 930 685">X968</td> <td data-bbox="930 607 1455 685">Safe torque off function with safety relay (option +Q968)</td> </tr> <tr> <td data-bbox="815 685 930 775">X954</td> <td data-bbox="930 685 1455 775">Ground fault monitoring for IT (ungrounded) systems (option +Q954)</td> </tr> <tr> <td data-bbox="815 775 930 887">X969</td> <td data-bbox="930 775 1455 887">External STO customer connection for safety options +Q951, +Q952, +Q963, +Q964, +Q957 and +Q971</td> </tr> <tr> <td data-bbox="815 887 930 1088">X601, X602, X603, X604 or X605</td> <td data-bbox="930 887 1455 1088">Starter for auxiliary motor fan (options +M601...+M605)</td> </tr> <tr> <td data-bbox="815 1088 930 1559">X506</td> <td data-bbox="930 1088 1455 1559">Thermistor relay or Pt100 relays (option +L505 or +L506)</td> </tr> </tbody> </table>		Terminals for	X250	Auxiliary contacts of optional line contactor (+F250)	X289	Auxiliary contacts of optional molded case circuit breaker (MCCB) (+F289)	X951, X952, X963 or X964	Push buttons for emergency stop options +Q951, +Q952, +Q963 and +Q964	X968	Safe torque off function with safety relay (option +Q968)	X954	Ground fault monitoring for IT (ungrounded) systems (option +Q954)	X969	External STO customer connection for safety options +Q951, +Q952, +Q963, +Q964, +Q957 and +Q971	X601, X602, X603, X604 or X605	Starter for auxiliary motor fan (options +M601...+M605)	X506	Thermistor relay or Pt100 relays (option +L505 or +L506)
	Terminals for																		
X250	Auxiliary contacts of optional line contactor (+F250)																		
X289	Auxiliary contacts of optional molded case circuit breaker (MCCB) (+F289)																		
X951, X952, X963 or X964	Push buttons for emergency stop options +Q951, +Q952, +Q963 and +Q964																		
X968	Safe torque off function with safety relay (option +Q968)																		
X954	Ground fault monitoring for IT (ungrounded) systems (option +Q954)																		
X969	External STO customer connection for safety options +Q951, +Q952, +Q963, +Q964, +Q957 and +Q971																		
X601, X602, X603, X604 or X605	Starter for auxiliary motor fan (options +M601...+M605)																		
X506	Thermistor relay or Pt100 relays (option +L505 or +L506)																		

■ **Door switches and lights**



	Label in English	Label in local language	Description				
1	READY	-	Ready light (option +G327)				
2	RUN	-	Run light (option+G328)				
3	FAULT	-	Fault light (option +G329)				
4	MAIN CONTACTOR OFF-ON 	-	Operating switch with line contactor (Q2, option +F250) <table border="1" style="width: 100%;"> <tr> <td>0</td> <td>Opens the main contactor (Q2) and disables starting of the drive.</td> </tr> <tr> <td>1</td> <td>Closes the main contactor (Q2).</td> </tr> </table>	0	Opens the main contactor (Q2) and disables starting of the drive.	1	Closes the main contactor (Q2).
0	Opens the main contactor (Q2) and disables starting of the drive.						
1	Closes the main contactor (Q2).						
5	EMERGENCY STOP RE-SET	-	Emergency stop reset push button (with emergency stop options only)				
6	GROUND FAULT RESET	-	Ground (earth) fault light with option +Q954				
7	-	-	Reserved for application-engineered equipment				
8	EMERGENCY STOP	-	Emergency stop push button (with emergency stop options only)				

The layout depends on the options selected.

■ **Main switch-disconnector (Q1)**

The switch-disconnector handle switches the main voltage to the drive on and off.

■ **Other devices on the door**

- Voltmeter (option +G334); comes with a phase selector switch.
Note: The voltage is measured on the supply side of the main switch or breaker.
- AC current meter (option +G335) on one phase.

■ Control panel

The ACS-AP-W is the user interface of the drive. It provides the essential controls such as Start/Stop/Direction/Reset/Reference, and the parameter settings for the inverter control program.

One control panel can be used to control several drives through a panel link.

The control panel can be removed by pulling it forward by the top edge and reinstalled in reverse order. For the use of the control panel, see *ACx-AP-x assistant control panels user's manual* (3AUA0000085685 [English]) and the firmware manual.



Control by PC tools

There is a USB connector on the front of the panel that can be used to connect a PC to the drive. When a PC is connected to the control panel, the control panel keypad is disabled.

Descriptions of options

Note: All options are not available for all drive types, do not coexist with certain other options, or may require additional engineering. Check actual availability with ABB.

■ Degree of protection

Definitions

According to IEC/EN 60529, the degree of protection is indicated by an IP code where the first numeral means protection against ingress of solid foreign objects, and the second numeral protection against ingress of water. The IP codes of the standard cabinet and options covered in this manual are defined below.

IP code	The equipment is protected ...	
	First numeral	Second numeral
IP22	against ingress of solid foreign objects > 12.5 mm diameter *	against dripping (15° tilting) water
IP42	against ingress of solid foreign objects > 1 mm	against dripping (15° tilting) water
IP54	dust-protected	against splashing water

* meaning for protection of persons: against access to hazardous parts with finger

IP22 (UL Type 1)

The degree of protection of the standard drive cabinet is IP22 (UL type 1). The air outlets at the top of the cabinet and the air inlet gratings are covered with metallic gratings. With doors open, the degree of protection of the standard cabinet and all cabinet options is IP20. The live parts inside the cabinet are protected against contact with clear plastic shrouds or metallic gratings.

IP42 (UL Type 1 Filtered) (option +B054)

This option provides the degree of protection of IP42 (UL type 1). The air inlet gratings are covered with a metallic mesh between the inner and outer metallic gratings.

IP54 (UL Type 12) (option +B055)

This option provides the degree of protection of IP54 (UL type 12). It provides the cabinet air inlets with filter housings containing folded board air filter mats between the inner and outer metallic gratings. An additional fan and filtered outlets on the cabinet roof are also included.

■ **Marine construction (option +C121)**

The option includes the following accessories and features:

- reinforced mechanics
- grab railings
- door flush bolt which allows the door to open 90 degrees and prevents it from slamming close
- self-extinctive materials
- flat bars at base of the cabinet for fastening
- fastening brackets at the top of the cabinet.

Additional wire markings may be required for classification. See section [Wire markings \(page 53\)](#).

■ **Cooling air intake through bottom of cabinet (option +C128)**

See section [Air inlet through the bottom of cabinet \(option +C128\) \(page 82\)](#).

■ **UL Listed (option +C129)**

The cabinet contains the following accessories and features:

- all components UL/CSA Listed/Recognized
- maximum supply voltage 600 V
- US-type main switch and fuses.

■ **Channeled air outlet (option +C130)**

This option provides a collar for connection to an air outlet duct. The collar is located on the cabinet roof. Depending on the equipment installed in each cubicle, the channeled air outlet either replaces, or adds to, the standard roof arrangement.

With option +B055, this option also provides the cabinet air inlets with filter housings containing folded board air filter mats between the inner and outer metallic gratings.

See also section [Air outlet duct on the cabinet roof \(option +C130\) \(page 83\)](#).

■ **CSA Approved (option +C134)**

The option includes the following accessories and features:

- bottom entry and exit of cables with US cable conduit entry (plain plate without ready-made holes)
- all components UL/CSA listed/recognized
- maximum supply voltage 600 V
- main (air circuit) breaker when available for the particular drive type.

■ **Plinth height (options +C164 and +C179)**

The standard height of the cabinet plinth is 50 mm. These options specify a plinth height of 100 mm (+C164) or 200 mm (+C179).

■ **Seismic design (option +C180)**

The option involves seismic capability according to International building code 2012, test procedure ICC-ES AC-156. The installation level must not exceed 25% of the height of the building, and S_{DS} (installation site specific spectral acceleration response) must not exceed 2.0 g.

The option adds the following accessories and features:

- reinforced mechanics
- flat bars at base of the cabinet for fastening.

■ **Empty cubicles on right (options +C196...C198)**

The option adds an empty 400, 600 or 800 mm wide cubicle to the right end of the line-up. The cubicle is equipped with blank power cable entries both at the top and the bottom.

The cubicle is equipped with blank panel entries (full panel or two-half panels) on the back.

■ **Empty cubicles on left (options +C199...C201)**

The option adds an empty 400, 600 or 800 mm wide cubicle to the left end of the line-up. The cubicle is equipped with blank power cable entries both at the top and the bottom.

The cubicle is equipped with blank panel entries (full panel or two-half panels) on the back.

■ **Resistor braking (options +D150 and +D151)**

See chapter Resistor braking.

■ **du/dt filter (option +E205)**

The du/dt filter protects the motor insulating system by reducing the voltage rise speed at the motor terminals. The filter also protects the motor bearings by reducing the bearing currents.

More information on when the option is required: See section [Examining the compatibility of the motor and drive \(page 86\)](#).

■ **Sine filter (option +E206)**

A sine filter provides true sinusoidal voltage waveform at the drive output by suppressing the high-frequency voltage components of the output. These high-frequency components cause stress to motor insulation as well as output transformer saturation (if present).

The sine filter option consists of three single-phase reactors and delta-connected capacitors at the output of the drive. The filter is fitted in a separate cubicle and has a dedicated cooling fan.

■ **Common mode filter (option +E208)**

The common mode filter contains ferrite rings mounted around the AC output busbars in the drive module. The filter protects the motor bearings by reducing the bearing currents.

More information on when the option is required: See section [Examining the compatibility of the motor and drive \(page 86\)](#).

■ **Molded case circuit breaker (MCCB, option +F289)**

This option replaces the standard main switch with a molded case circuit breaker. The breaker has inbuilt protection functions against overload and short-circuit. It is operated with a direct rotary handle on the cabinet door.

For North American market only.

■ **Cabinet heater with external supply (option +G300)**

The option contains:

- heating elements in the cubicles or supply/inverter modules
- load switch for providing electrical isolation during service
- miniature circuit breaker for overcurrent protection
- terminal block for external power supply.

The heater prevents humidity condensation inside the cabinet when the drive is not running. The power output of the semiconductor-type heating elements depends on the environmental temperature. The customer must switch the heating off when it is not needed by cutting the supply voltage off.

The customer must supply the heater from an external 110...240 V AC power source.

For the actual wiring, see the circuit diagrams delivered with drive.

■ **Cabinet lighting (option +G301)**

This option contains LED lighting fixtures in each cubicle (except joining and brake resistor cubicles) and a 24 V DC power supply. The lighting is powered from the same external 110...240 V AC power source as the cabinet heater (option +G300).

■ **Terminals for external control voltage (option +G307)**

The option provides terminals for connecting an external uninterruptible control voltage to the control unit and control devices when the drive is not powered.

See also:

- [Supplying power for the auxiliary circuits \(page 103\)](#)
- circuit diagrams delivered with drive for the actual wiring.

■ **Output for motor space heater (option +G313)**

The option contains:

- load switch for providing electrical isolation during service
- miniature circuit breaker for overcurrent protection
- terminal block for heater and external heater supply connection.

When the drive is running, the heater is switched off. Otherwise, the heater is controlled by the external supply voltage.

The power and voltage of the heater depend on the motor.

See also:

- [Supplying power for the auxiliary circuits \(page 103\)](#)
- circuit diagrams delivered with drive for the actual wiring.

■ **Ready/Run/Fault lights (options +G327...G329)**

These options provide "ready" (+G327, white), "run" (+G328, green) and "fault" (+G329, red) lights installed on the cabinet door.

■ **Halogen-free wiring and materials (option +G330)**

The option provides halogen-free cable ducts, control wires and wire sleeves, thus reducing toxic fire gases.

■ **V-meter with selector switch (option +G334)**

The option contains a voltmeter and a selector switch on the cabinet door. The switch selects the two input phases across which the voltage is measured.

■ **A-meter in one phase (option +G335)**

The option contains an ammeter that reads the current flowing through one input phase.

■ **Wire markings**

Standard wiring

Color

The standard color of the wiring is black, with the following exceptions:

- PE wiring: Yellow/Green, or yellow/green sleeving
- UPS input wiring (option +G307): Orange
- Pt100 sensor wiring with ATEX-certified thermal protection (option +nL514): Light blue.

Markings



As standard, wires and terminals are marked as follows:

- Main circuit terminals: Connector identifier (eg. "U1") marked on terminal, or on insulating material close to the terminal. Input and output main circuit cables are not marked.
 - Plug-in connectors of wire sets (except those that require special tools to disconnect) are labeled with connector designation (eg. "X1"). The marking is either directly on the connector, or near the connector on printed sleeving or tape.
 - Grounding busbars are marked with stickers.
 - Fiber optic cable pairs and data cables have component designation and connector designations (eg. "A1:V1", "A1:X1") marked with rings or tape.
-

- Data cables are marked with tape.
- Ribbon cables are marked with either labels or tape.
- Customer-specific (engineered) wiring (option +P902) is not marked.

Additional wire markings

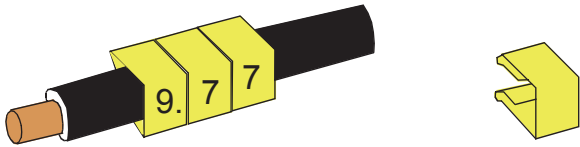
The following additional wire markings are available.

Option	Additional markings
+G340 (class A3)	<p>Single wires not attached to plug-in connectors are marked with component pin numbers on snap-on or ring markers. Plug-in connectors are marked with an identification label placed on the wires near the connector (individual wires are not marked). Short, obvious connections are not marked. PE wires are not marked unless connected directly to components.</p> 
+G342 (class C1)	<p>Single wires connected to components, between modules, or to terminal blocks are marked with component identification and pin numbers for both ends. The marking is printed on sleeving or, if necessary, snap-on markers. Plug-in connectors are marked with an identification label (or snap-on markers) placed on the wires near the connector (individual wires are not marked). Short, obvious connections are not marked. PE wires are not marked unless connected directly to components.</p> 

■ Bottom cable entry/exit (options +H350 and +H352)

For UL Listed (+C129) units, the default input and output cabling direction is through the roof of the cabinet. The bottom entry (+H350) and bottom exit (+H352) options provide power and control cable entries at the floor of the cabinet. The entries are equipped with grommets and 360° grounding hardware.

For non-UL Listed units, bottom entry/exit is the default cabling arrangement.

■ Top cable entry/exit (options +H351 and +H353)

The top entry (+H351) and top exit (+H353) options provide power and control cable entries at the roof of the cabinet. The entries are equipped with grommets and 360° grounding hardware.

■ Cable conduit entry (option +H358)

The option provides US/UK conduit plates (plain 3 mm thick steel plates without any ready-made holes).

■ Additional terminal block X504 (option +L504)

The standard terminal blocks of the drive control unit are wired to the additional terminal block at the factory for customer control wiring. The terminals are spring loaded.

Note: The optional modules inserted in the slots of the control unit are not wired to the additional terminal block. The customer must connect the optional module control wires directly to the modules.

■ **Thermal protection with PTC relays (options +L505, +2L505, +L513, +2L513, +L536, +L537)**

PTC thermistor relay options are used for overtemperature supervision of motors equipped with PTC sensors. When the motor temperature rises to the thermistor wake-up level, the resistance of the sensor increases sharply. The relay detects the change and indicates motor overtemperature through its contacts.

+L505, +2L505, +L513, +2L513

Option +L505 provides a thermistor relay and a terminal block. The terminal block has connections for the measuring circuit (one to three PTC sensors in series), an output indication of the relay, and an optional external reset button. The relay can be reset either locally or externally, or the reset circuit can be jumpered for automatic reset.

By default, the thermistor relay is wired internally to digital input DI6 of the drive control unit. The loss of the input is set to trigger an external fault.

The output indication on the terminal block can be wired by the customer, for example, to an external monitoring circuit. See the circuit diagrams delivered with the drive.

Option +L513 is an ATEX-certified thermal protection function that has the same external connectivity as +L505. In addition, +L513 comes with +Q971 (ATEX-certified safe disconnection function) as standard and is wired at the factory to activate the Safe torque off function of the drive in an overtemperature situation. A manual reset for the protection function is required by Ex/ATEX regulations. For more information, see *ATEX-certified motor thermal protection functions for cabinet-built ACS880 drives (options +L513+Q971 and +L514+Q971) user's manual (3AXD50000014979 [English])*.

Options +2L505 and +2L513 duplicate options +L505 and +L513 respectively, containing the relays and connections for two separate measurement circuits.

+L536, +L537

An alternative to a thermistor relay option is the FPTC-01 (option +L536) or FPTC-02 (+L537, also requires +Q971) thermistor protection module. The module mounts onto the inverter control unit, and has reinforced insulation to keep the control unit PELV-compatible. The connectivity of the FPTC-01 and the FPTC-02 is the same; FPTC-02 is Type Examined as a protective device within the scope of the European ATEX Product Directive.

For protection purposes, the FPTC has a "fault" input for the PTC sensor. An overtemperature situation executes the SIL/PL-capable SMT (Safe motor temperature) safety function by activating the Safe torque off function of the drive.

The FPTC also has a "warning" input for the sensor. When the module detects overtemperature through this input, it sends a warning indication to the drive.

For more information and wiring examples, see the module manuals and the circuit diagrams delivered with the drive.

See also

- firmware manual for parameter settings
 - *ATEX-certified motor thermal protection functions for cabinet-built ACS880 drives (options +L513+Q971 and +L514+Q971) user's manual (3AXD50000014979 [English])*
-

- *FPTC-01 thermistor protection module (option +L536) for ACS880 drives user's manual (3AXD50000027750 [English])*
- *FPTC-02 ATEX-certified thermistor protection module, Ex II (2) GD (option +L537+Q971) for ACS880 drives user's manual (3AXD50000027782 [English])*
- circuit diagrams delivered with the drive for the actual wiring.

■ **Thermal protection with Pt100 relays (options +nL506, +nL514)**

Pt100 temperature monitoring relays are used for overtemperature supervision of motors equipped with Pt100 sensors. For example, there can be three sensors to measure the temperature of the motor windings and two sensors for the bearings. As the temperature rises, the sensor resistance increases linearly. At an adjustable wake-up level, the monitoring relay de-energizes its output.

The standard Pt100 relay options include two (+2L506), three (+3L506), five (+5L506) or eight (+8L506) relays. By default, the relays are wired internally to digital input DI6 of the drive control unit. The loss of the input is set to trigger an external fault. The options include a terminal block for sensor connection. The output indication on the terminal block can be wired by the customer, for example, to an external monitoring circuit. See the circuit diagrams delivered with the drive.

Options +3L514 (3 relays) and +5L514 (5 relays) are ATEX-certified thermal protection functions that have the same external connectivity as +nL506. In addition, each monitoring relay has a 0/4...20 mA output that is available on the terminal block. Option +nL514 comes with +Q971 (ATEX-certified safe disconnection function) as standard and is wired at the factory to activate the Safe torque off function of the drive in an overtemperature situation. As the monitoring relay does not have a reset functionality, the manual reset required by Ex/ATEX regulations must be implemented using drive parameters. For more information, see *ATEX-certified motor thermal protection functions for cabinet-built ACS880 drives (options +L513+Q971 and +L514+Q971) user's manual (3AXD50000014979 [English])*.

See also

- firmware manual for parameter settings
- *ATEX-certified motor thermal protection functions for cabinet-built ACS880 drives (options +L513+Q971 and +L514+Q971) user's manual (3AXD50000014979 [English])*
- Pt100 relay alarm and trip limit setting instructions in the start-up instructions
- circuit diagrams delivered with the drive for the actual wiring.

■ **Starter for auxiliary motor fan (options +M6xx)**

What the option contains

The option provides switched and protected connections for 3-phase auxiliary motor fans. Each fan connection is equipped with

- fuses
- a manual motor starter switch with an adjustable current limit
- a contactor controlled by the drive, and
- terminal block X601 for customer connections.

The number of connections must be specified when ordering. The maximum number of connections available depends on the current requirement. The lower current ratings allow up to four fan connections (eg. option +4M602), while the highest current rating only allows

one (eg. +M610). For more information, refer to *ACS880-X7 single drives ordering information* (3AXD10000052815, available on request).

Description

The output for the auxiliary fan is wired from the 3-phase supply voltage to terminal block X601 through a motor starter switch and a contactor. The contactor is operated by the drive. The 230 V AC control circuit is wired through a jumper on the terminal block; the jumper can be replaced by an external control circuit.

The starter switch has an adjustable trip current limit, and can be opened to permanently switch the fan off.









The statuses of both the starter switch and the fan contactor are wired to the terminal block.

See the circuit diagrams delivered with the drive for the actual wiring.

Type designation label

The type designation label includes ratings, appropriate markings, a type designation and a serial number, which allow identification of each unit. The type designation label is located on the front cover. A sample label is shown below.

Quote the complete type designation and serial number when contacting technical support.

 <p>Origin Estonia Made in Estonia ABB Oy Hiomotie 13 00380 Helsinki Finland</p>		<p>① ACS880-07-0061A-7+C134+C179+E200+E205+L501+L504+3L506+P909+Q973+Q979</p>		  																										
<p>②</p>		<p>⑥</p> <table border="0"> <tr> <td>Input</td> <td>U1</td> <td>3~ 525/600/690 VAC</td> </tr> <tr> <td></td> <td>I1</td> <td>62/62/61 A</td> </tr> <tr> <td></td> <td>f1</td> <td>50/60 Hz</td> </tr> <tr> <td>Output</td> <td>U2</td> <td>3~ 0...U1</td> </tr> <tr> <td></td> <td>I2</td> <td>62/62/61 A</td> </tr> <tr> <td></td> <td>f2</td> <td>0...500 Hz</td> </tr> <tr> <td></td> <td>Sn</td> <td>73 kVA</td> </tr> </table>		Input	U1	3~ 525/600/690 VAC		I1	62/62/61 A		f1	50/60 Hz	Output	U2	3~ 0...U1		I2	62/62/61 A		f2	0...500 Hz		Sn	73 kVA	<p>⑧</p>   		<p>③</p> <table border="1"> <tr> <td>FRAME</td> </tr> <tr> <td>R6</td> </tr> </table>		FRAME	R6
Input	U1	3~ 525/600/690 VAC																												
	I1	62/62/61 A																												
	f1	50/60 Hz																												
Output	U2	3~ 0...U1																												
	I2	62/62/61 A																												
	f2	0...500 Hz																												
	Sn	73 kVA																												
FRAME																														
R6																														
<p>④</p> <p>Air cooling</p>		<p>⑦</p> <p>Icc 65 kA</p>		<p>⑨</p> <p>MSIP-REI-Abb-ACS880-0271A-7</p>  <p>S/N: 8200802684</p>																										
<p>⑤</p> <p>IP22 Type 1 UL/CSA: max. 600 VAC</p>		<p>⑩</p> 																												
1	Type designation, see section Type designation key below.																													
2	Manufacturing address																													
3	Frame size																													
4	Cooling method																													
5	Degree of protection; UL/CSA specifications																													
6	Ratings, see also chapter Technical data (page 197)																													
7	Short-circuit withstand strength, see section Electrical power network specification (page 224)																													
8	Valid markings																													
9	Serial number. The first digit of the serial number refers to the manufacturing plant. The next four digits refer to the unit's manufacturing year and week, respectively. The remaining digits complete the serial number so that there are no two units with the same number.																													
10	Link to product information																													

Type designation key

The type designation contains information on the specifications and configuration of the drive. The first digits from left express the basic configuration (eg, ACS880-07-240A-5). The optional selections are given thereafter, separated by plus signs, eg, +E202. The main selections are described below. Not all selections are available for all types. For more information, refer to *ACS880-X7 single drives ordering information* (3AXD10000052815, available on request).

■ Basic codes

Code	Description
ACS880	Product series
07	When no options are selected: cabinet-installed drive, IP22 (UL Type 1), main switch-disconnector (switch fuse with aR fuses), ACS-AP-W assistant control panel with Bluetooth interface, no EMC filter, built-in input DC choke (frames R6 to R9), built-in input AC choke (frames R10 and R11), coated boards, ACS880 primary control program, Safe torque off function, bottom entry and exit of cables, multilingual device label sticker, USB memory containing circuit diagrams and all manuals.
Size	
xxxx	See <i>Ratings (page 197)</i> .
Voltage range	
3	380...415 V. This is indicated in the type designation label as typical input voltage level 3 ~ 400 V AC.
5	380...500 V. This is indicated in the type designation label as typical input voltage levels 3 ~ 400/480/500 V AC.
7	525...690 V. This is indicated in the type designation label as typical input voltage levels 3 ~ 525/600/690 V AC.

■ Option codes

Code	Description
B054	IP42 (UL Type 1 Filtered)
B055	IP54 (UL Type 12)
C121	Marine construction. See section <i>Marine construction (option +C121) (page 50)</i> .
C128	Air inlet through bottom of cabinet. See section <i>Air inlet through the bottom of cabinet (option +C128) (page 82)</i> .
C129	UL Listed (evaluated to both U.S. and Canadian safety requirements). See section <i>UL Listed (option +C129) (page 50)</i> .
C130	Channeled air outlet. See section <i>Channeled air outlet (option +C130) (page 50)</i> .
C132	Marine type approval. Refer to <i>ACS880 +C132 marine type-approved cabinet-built drives supplement</i> (3AXD50000039629 [English]).
C134	CSA approved. See section <i>CSA Approved (option +C134) (page 51)</i> .
C164	Plinth height 100 mm. See section <i>Plinth height (options +C164 and +C179) (page 51)</i> .
C179	Plinth height 200 mm. See section <i>Plinth height (options +C164 and +C179) (page 51)</i> .
C180	Seismic design. See section <i>Seismic design (option +C180) (page 51)</i> .
C196	Empty 400 mm wide cubicle on right. See section <i>Empty cubicles on right (options +C196...C198) (page 51)</i> .
C197	Empty 600 mm wide cubicle on right. See section <i>Empty cubicles on right (options +C196...C198) (page 51)</i> .

60 Operation principle and hardware description

Code	Description
C198	Empty 800 mm wide cubicle on right. See section <i>Empty cubicles on right (options +C196...C198) (page 51)</i> .
C199	Empty 400 mm wide cubicle on left. See section <i>Empty cubicles on left (options +C199...C201) (page 51)</i> .
C200	Empty 600 mm wide cubicle on left. See section <i>Empty cubicles on left (options +C199...C201) (page 51)</i> .
C201	Empty 800 mm wide cubicle on left. See section <i>Empty cubicles on left (options +C199...C201) (page 51)</i> .
C205	Marine product certification issued by DNV GL
C206	Marine product certification issued by the American Bureau of Shipping (ABS)
C207	Marine product certification issued by Lloyd's Register (LR)
C209	Marine product certification issued by Bureau Veritas
C228	Marine product certification issued by China Classification Society (CCS)
C229	Marine product certification issued by Russian Maritime Register of Shipping (RS)
D150	Brake choppers
D151	Brake resistors
E200	EMC/RFI filter for 2nd environment TN (grounded) system, category C3
E201	EMC/RFI filter for 2nd environment IT (ungrounded) system, category C3 For frame R6 690 V: EMC/RFI filter for 2nd environment IT (ungrounded) system, category C4
E202	EMC/RFI filter for 1st environment TN (grounded) system, category C2
E205	du/dt filtering
E206	Sine output filter
E208	Common mode filtering (standard with frames R6i, R7i, R8i and multiples)
F250	Main (line) contactor
F277	Flange-mounted switch for MCCB
F289	MCCB circuit breaker
G300	Cabinet and module heating elements (external supply). See section <i>Cabinet heater with external supply (option +G300) (page 52)</i> .
G301	Cabinet lighting. See section <i>Cabinet lighting (option +G301) (page 52)</i> .
G307	Terminals for connecting external control voltage (230 V AC or 115 V AC, eg. UPS). See section <i>Terminals for external control voltage (option +G307) (page 52)</i> .
G313	Output for motor space heater (external supply)
G327	Ready light on door, white
G328	Run light on door, green
G329	Fault light on door, red
G330	Halogen-free wiring and materials
G334	V-meter with selector switch
G335	A-meter in one phase
G340	Additional wire markings. See section <i>Wire markings (page 53)</i> .
G342	
H350	Bottom power cable entry. See section <i>Bottom cable entry/exit (options +H350 and +H352) (page 54)</i> .
H351	Top power cable entry. See section <i>Top cable entry/exit (options +H351 and +H353) (page 54)</i> .

Code	Description
H352	Motor cabling direction down. See section <i>Bottom cable entry/exit (options +H350 and +H352) (page 54)</i> .
H353	Motor cabling direction up. See section <i>Top cable entry/exit (options +H351 and +H353) (page 54)</i> .
H356	DC cable connection busbars
H358	Cable gland plates (3 mm steel, undrilled)
J425	ACS-AP-I control panel (without Bluetooth)
K451	FDNA-01 DeviceNet™ adapter module
K454	FPBA-01 PROFIBUS DP adapter module
K457	FCAN-01 CANopen adapter module
K458	FSCA-01 RS-485 (Modbus/RTU) adapter module
K462	FCNA-01 ControlNet™ adapter module
K469	FECA-01 EtherCat adapter module
K470	FEPL-02 EtherPOWERLINK adapter module
K475	FENA-21 Ethernet adapter module for EtherNet/IP™, Modbus TCP and PROFINET IO protocols, 2-port
K490	FEIP-21 Ethernet adapter module for EtherNet/IP™
K491	FMBT-21 Ethernet adapter module for Modbus TCP
K492	FPNO-21 Ethernet adapter module for PROFINET IO
L500	FIO-11 analog I/O extension module
L501	FIO-01 digital I/O extension module
L502	FEN-31 HTL incremental encoder interface module
L503	FDCO-01 optical DDCS communication adapter module
L504	Additional I/O terminal block. See section <i>Additional terminal block X504 (option +L504) (page 54)</i> .
L505	Thermal protection with PTC relays (1 or 2 pcs). See section <i>Thermal protection with PTC relays (options +L505, +2L505, +L513, +2L513, +L536, +L537) (page 55)</i> .
L506	Thermal protection with Pt100 relays (2, 3, 5 or 8 pcs). See section <i>Thermal protection with Pt100 relays (options +nL506, +nL514) (page 56)</i> .
L508	FDCO-02 optical DDCS communication adapter module
L513	ATEX-certified thermal protection with PTC relays (1 or 2 pcs)
L514	ATEX-certified thermal protection with Pt100 relays (3 or 5 pcs)
L515	FEA-03 I/O extension adapter
L516	FEN-21 resolver interface module
L517	FEN-01 TTL incremental encoder interface module
L518	FEN-11 TTL absolute encoder interface module
L521	FSE-31 pulse encoder interface module
L525	FAIO-01 analog I/O extension module
L526	FDIO-01 digital I/O extension module
L536	FPTC-01 thermistor protection module
L537	FPTC-02 ATEX-certified thermistor protection module
M600	Starter for auxiliary motor fan, trip limit 1 ... 1.6 A
M601	Starter for auxiliary motor fan, trip limit 1.6 ... 2.5 A
M602	Starter for auxiliary motor fan, trip limit 2.5 ... 4 A

62 Operation principle and hardware description

Code	Description
M603	Starter for auxiliary motor fan, trip limit 4 ... 6.3 A
M604	Starter for auxiliary motor fan, trip limit 6.3 ... 10 A
M605	Starter for auxiliary motor fan, trip limit 10...16 A
N5000	Winder control program
N5050	Crane control program
N5100	Winch control program
N5200	PCP (Progressive Cavity Pump) control program
N5300	Test bench control program
N5350	Cooling tower control program
N5450	Override control program
N5600	ESP (Electrical Submersible Pump) control program
N5700	Position control program
N7502	Control program for synchronous reluctance motors (SynRM)
N8010	IEC 61131-3 application programmability
N8200	High speed (> 598 Hz) license
P902	Customized
P904	Extended warranty (30 months from delivery or 24 months from commissioning)
P909	Extended warranty (42 months from delivery or 36 months from commissioning)
P911	Extended warranty (66 months from delivery or 60 months from commissioning)
P912	Seaworthy packaging
P913	Special color (RAL Classic)
P947	Safety data calculation and validation for tailored safety functions
P948	Customized extended warranty
P952	Country of origin: Finland
P966	Special color (other than RAL Classic)
Q950	Prevention of unexpected start-up with FSO-xx safety functions module, by activating the Safe torque off function
Q951	Emergency stop (category 0) with safety relays, by opening the main breaker/contactor
Q952	Emergency stop (category 1) with safety relays, by opening the main breaker/contactor
Q954	Earth fault monitoring for IT (ungrounded) systems
Q957	Prevention of unexpected start-up with safety relays, by activating the Safe torque off function
Q963	Emergency stop (category 0) with safety relays, by activating the Safe torque off function
Q964	Emergency stop (category 1) with safety relays, by activating the Safe torque off function
Q965	Safely-limited speed with FSO-21 and encoder
Q971	ATEX-certified safe disconnection function
Q972	FSO-21 safety functions module
Q973	FSO-12 safety functions module
Q978	Emergency stop (configurable for category 0 or 1) with FSO-xx safety functions module, by opening the main breaker/contactor
Q979	Emergency stop (configurable for category 0 or 1) with FSO-xx safety functions module, by activating the Safe torque off function
Q982	PROFIsafe with FSO-xx safety functions module and FPNO-21 Ethernet adapter module
Q986	FSPS-21 PROFIsafe safety functions module

Code	Description
R700	Documentation/manuals in English
R701	Documentation/manuals in German
R702	Documentation/manuals in Italian
R703	Documentation/manuals in Dutch
R704	Documentation/manuals in Danish
R705	Documentation/manuals in Swedish
R706	Documentation/manuals in Finnish
R707	Documentation/manuals in French
R708	Documentation/manuals in Spanish
R709	Documentation/manuals in Portuguese
R711	Documentation/manuals in Russian
R712	Documentation/manuals in Chinese
R713	Documentation/manuals in Polish
R714	Documentation/manuals in Turkish

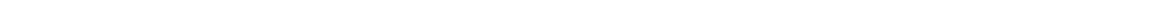

4

Mechanical installation

Contents of this chapter

This chapter describes the mechanical installation procedure of the drive.

Examining the installation site

Examine the installation site. Make sure that:

- The installation site is sufficiently ventilated or cooled to remove heat from the drive. See the technical data.
- The ambient conditions of the drive meet the specifications. See the technical data.
- There is sufficient free space above the drive for cooling, maintenance, and operation of the pressure relief (if present).
- The floor that the drive cabinet is installed on is of non-flammable material, as smooth as possible, and strong enough to support the weight of the unit. Check the floor flatness with a spirit level. The maximum allowed deviation from the surface level is 5 mm (0.2 in) in every 3 meters (10 ft). Level the installation site, if necessary, as the cabinet is not equipped with adjustable feet.



Do not install the drive on an elevated platform or a recess. The module extraction/installation ramp included with the drive is only suitable for a height difference of 50 mm (2 in) maximum (ie. the standard plinth height of the drive).

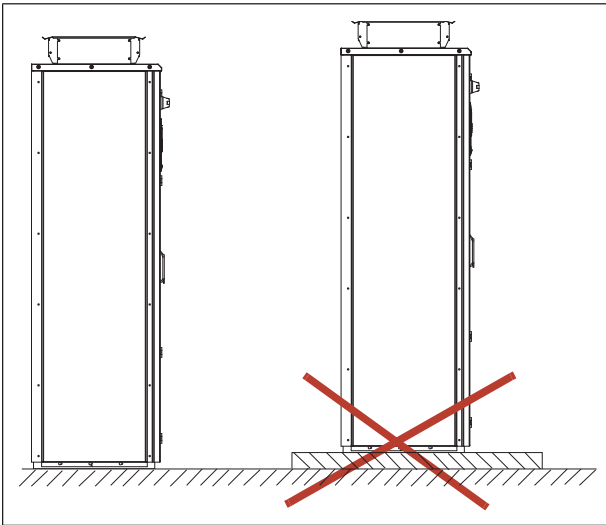

Necessary tools

The tools required for moving the unit to its final position, fastening it to the floor and wall and tightening the connections are listed below:

- crane, fork-lift or pallet truck (check load capacity!), slate/spud bar, jack and rollers
- Pozidriv and Torx screwdrivers
- torque wrench
- set of wrenches or sockets.

Moving the drive in its package

Move the drive in its original packaging to the installation site as shown below to avoid damaging the cabinet surfaces and door devices. When you are using a pallet truck, check its load capacity before you move the drive.

■ Horizontal package

Move the drive package in horizontal position, preferably in the original package to installation site as shown below to avoid damaging the cabinet surfaces and door devices. When you use a pallet truck, check its load capacity before you move the drive.

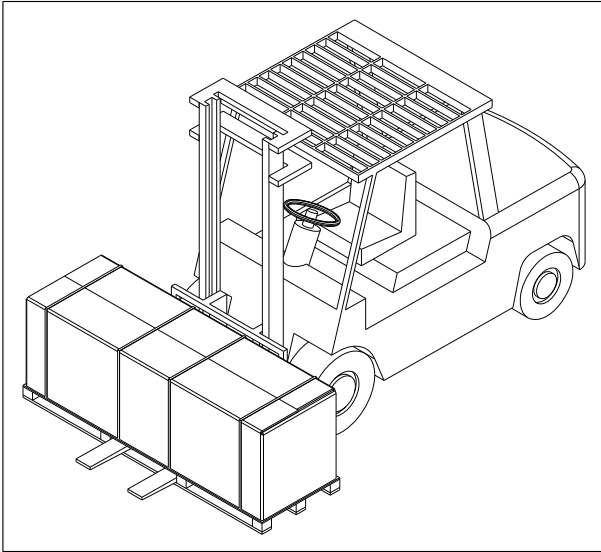

■ Vertical package

Move the drive package in vertical position, preferably in the original package to installation site as shown below to avoid damaging the cabinet surfaces and door devices. When you use a pallet truck, check its load capacity before you move the drive.

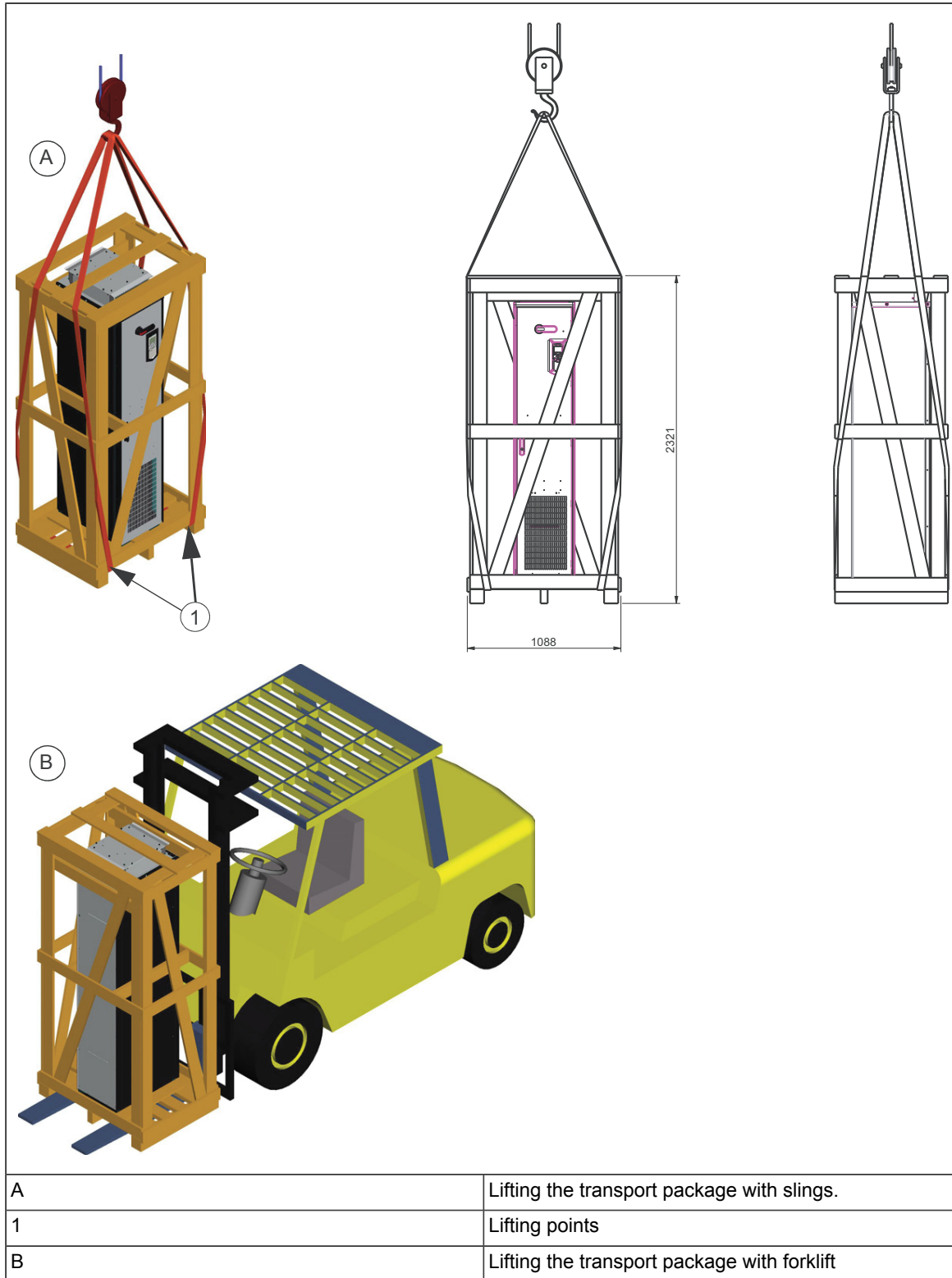

Unpacking the transport package

This drawing shows the layout of the horizontal transport package.

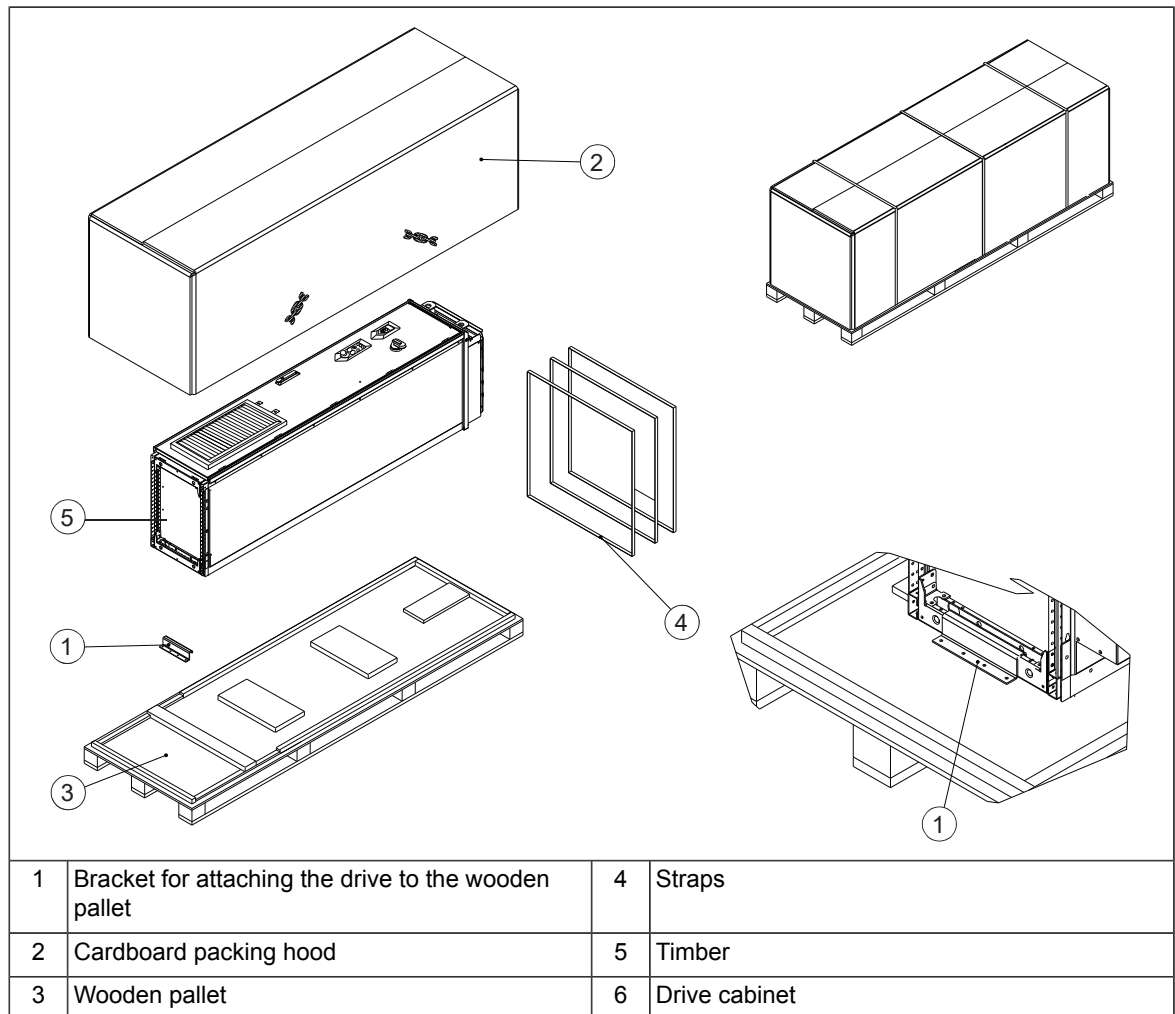

Unpack the horizontal transport package as follows:

1. Cut the straps (4).
2. Remove the hood (2).
3. Undo the screws that attach the bracket (1) to the wooden pallet.
4. Remove the plastic wrapping.

Unpack the vertical transport package as follows:

1. Undo the screws that attach the wooden parts of the transport crate to each other.
2. Remove the wooden parts.
3. Remove the clamps with which the drive cabinet is mounted onto the transport pallet by undoing the fastening screws.
4. Remove the plastic wrapping.

Lifting the cabinet

■ Lifting from the cabinet from the horizontal package

Lift the drive cabinet up using its lifting lugs.

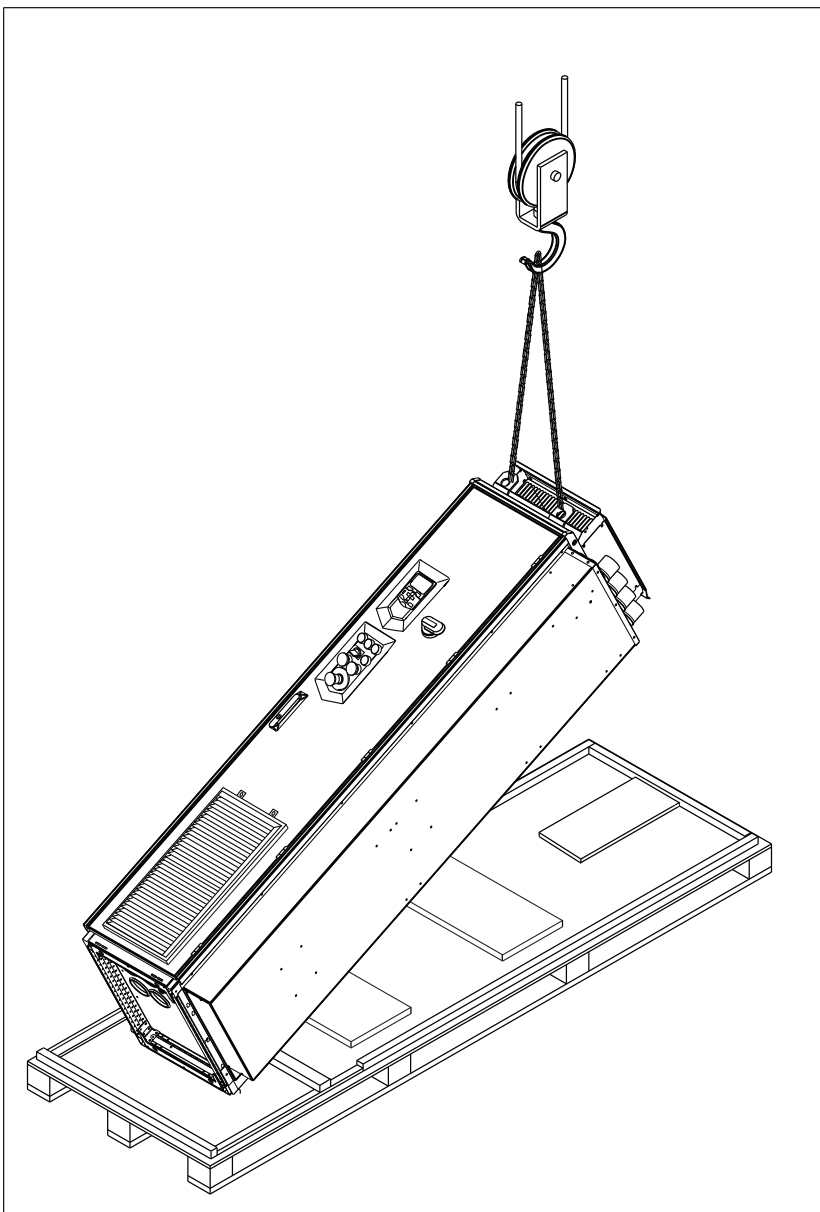

■ **Lifting the cabinet with crane**



WARNING!

Incorrect lifting can cause danger or damage. Obey the local laws and regulations applicable to lifting, such as requirements for planning the lift, for capacity and condition of lifting equipment, and for training of personnel.

Lift the drive cabinet by its designated lifting eyes. The lifting eyes can be removed after the cabinet is in its final position, but their mounting holes must be blocked to retain the degree of protection.

<p>IP22, IP42 (option +B054) UL Type 1, UL Type 1 Filtered (option +B054)</p>	<p>IP54, UL Type 12 Option +B055</p> <p>Note: The minimum allowed height of the lifting slings is 2 meters (6.7 ft).</p>



■ **Lifting lugs**

Certificate of conformity

The certificate is available in ABB Library at www.abb.com/drives/documents (document number 3AXD10001061361).

Declaration of Conformity



EU Declaration of Conformity

Machinery Directive 2006/42/EC

We

Manufacturer: ABB Oy

Address: Hiomotie 13, 00380 Helsinki, Finland.

Phone: +358 10 22 11

declare under our sole responsibility that the following products:

Lifting bars, identified with material codes

64300971	64301284	64301411	64485342
64301047	64301306	64456695	64485351
64301063	64301314	64456725	64485369
64301080	64301322	64456822	64485377
64301101	64301331	64456881	64485458
64301136	64301349	64456890	68775558
64301152	64301357	64456920	68775540
64301187	64301365	64485296	3AUA5000013498
64301209	64301373	64485300	3AUA5000013504
64301250	64301381	64485318	3AUA0000055356
64301268	64301390	64485326	3AXD50000435524
64301276	64301403	64485334	3AXD50000435548

Lifting lugs, identified with material codes

64302621 64327151

used for lifting the following **frequency converters** and **frequency converter components**

ACS800LC types -x7LC, LC multidrives, -x07LC

ACS580, ACH580, ACQ580 types -07

ACS880 types -x7, multidrives, -x07, -xx07

ACS880LC types -x7LC, LC multidrives, -x07LC, -xx07

identified with serial numbers beginning with 1 or 8





are in conformity with all the relevant lifting accessory requirements of EU Machinery Directive 2006/42/EC.

Person authorized to compile the technical file:
Name and address: Vesa Tiihonen, Hiomotie 13, 00380 Helsinki, Finland

Helsinki, 16 Dec 2019

Signed for and on behalf of:



Peter Lindgren
Vice President, ABB Oy



Vesa Tiihonen
Manager, Product Engineering and Quality

Moving the cabinet after unpacking

Move drive cabinet carefully in the upright position. Avoid tilting. The center of gravity of the cabinet is high.



■ **Moving the cabinet with rollers**



WARNING!

Do not move marine versions (option +C121) on rollers.

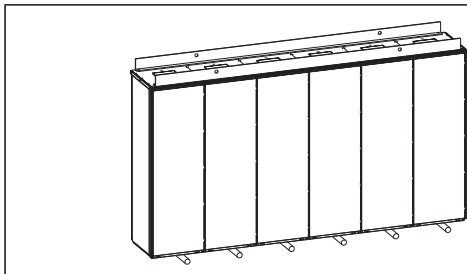

Lay the cabinet on the rollers and move it carefully until close to its final location.

Remove the rollers by lifting the unit with a crane, forklift, pallet truck or jack.

■ **Moving the cabinet to its final placement with a slate bar**

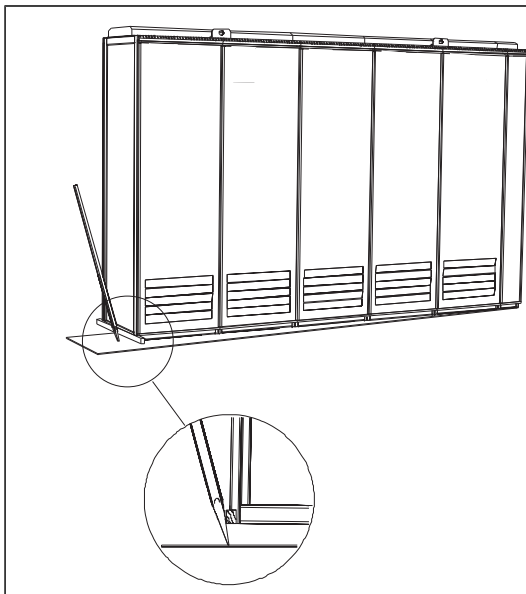

Move the cabinet into its final position with an iron bar. Place a wooden piece at the bottom edge of the cabinet in order not to damage the cabinet frame with the iron bar.

■ **Moving the cabinet on its back**



WARNING! Do not transport the drive with a sine filter (option +E206) on its back. It will damage the filter.

If you need to lay the cabinet on its back, support from below alongside the cubicle seams.

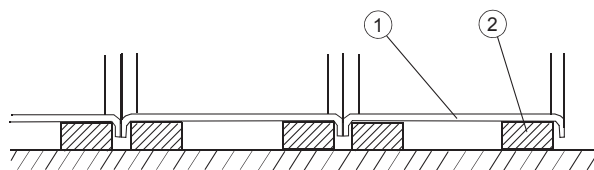

1	Cabinet back panel
2	Support

Installing the IP54 roof

If the roof of an IP54 cabinet is delivered in a separate package, install the roof as follows.

■ Frames R6 to R8

1. Undo the mounting screws of the front top profile of the cabinet and remove it.
2. Undo the back mounting screws of the roof from the cabinet top. See step 1 under section [Frames R10 and R11 \(page 76\)](#)
3. Remove the IP54 filter grating and connect the fan power supply wires.

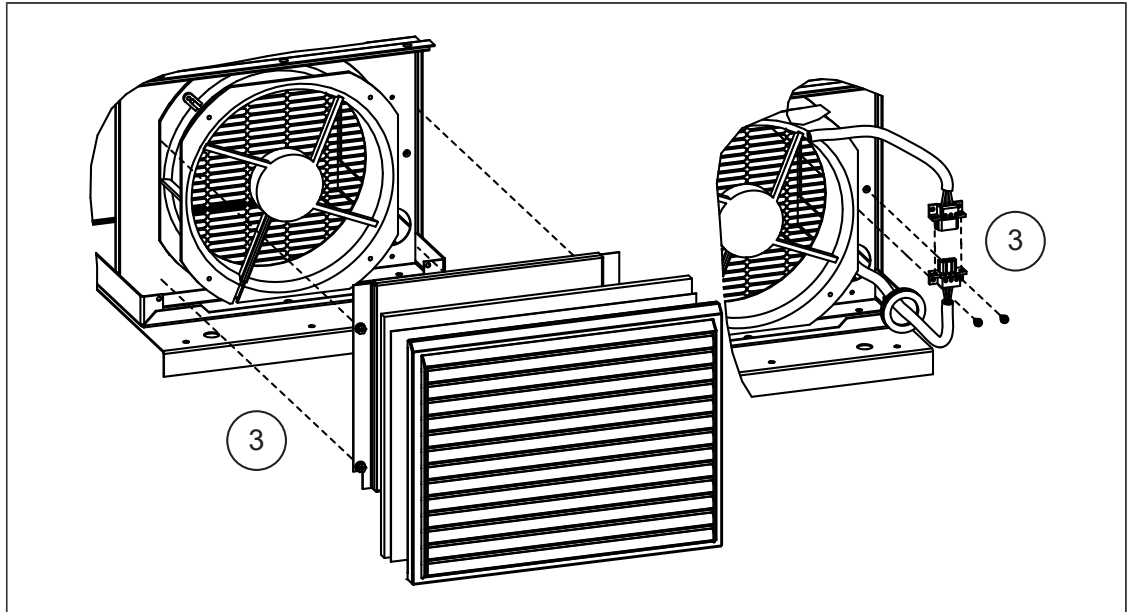

4. Install the front top profile of the cabinet in reverse order to step 1.
5. Fasten the back mounting screws of the roof.
6. Install the IP54 filter grating.



■ Frame R9

1. Undo the mounting screws of the front top profile of the cabinet and remove it. Undo the back mounting screws of the roof from the cabinet top. See step 1 under section [Frames R10 and R11 \(page 76\)](#)
2. Install the shroud to bottom of the fan assembly. Connect the fan supply wires.

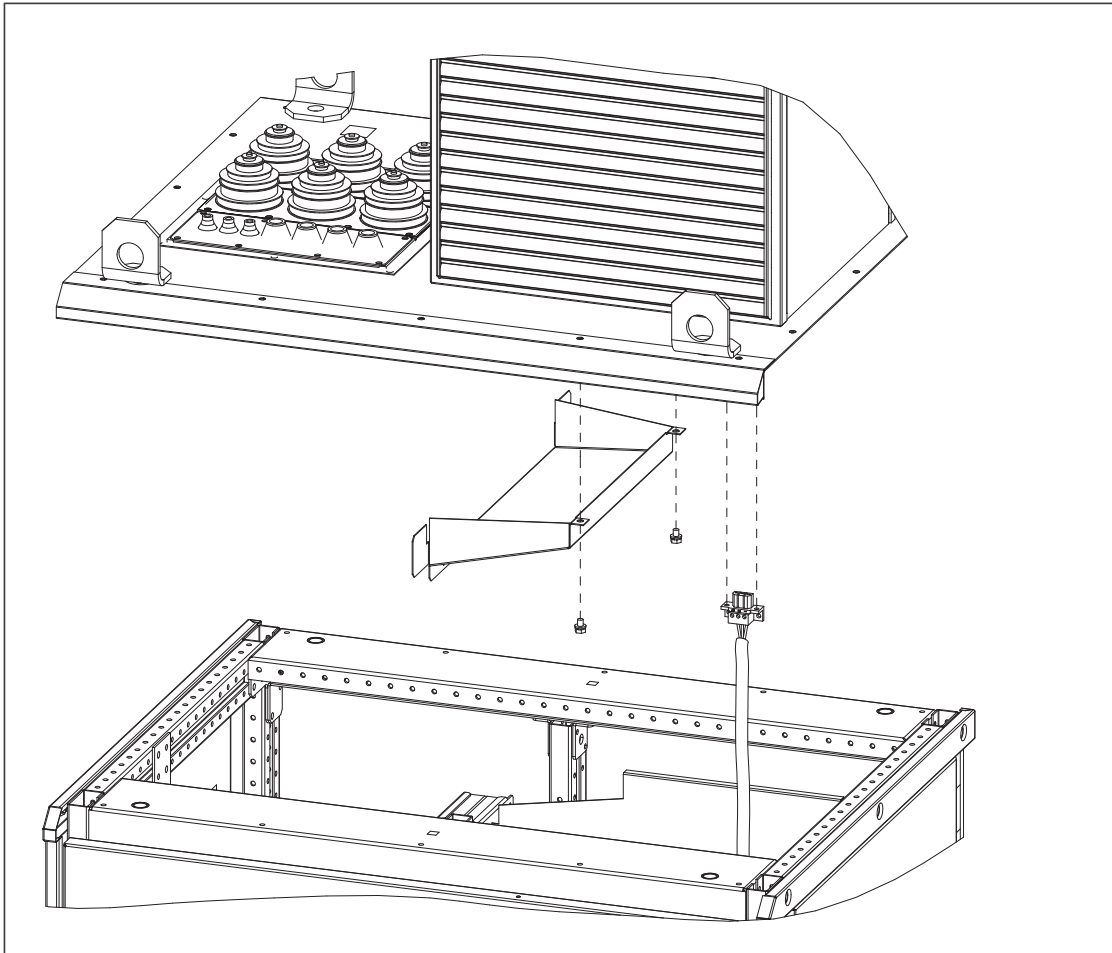

3. Install the front top profile of the cabinet in reverse order to step 1.
4. Fasten the back mounting screws of the roof.

■ Frames R10 and R11

1. To remove the top front and back profile of the cabinet, undo the mounting screws.
2. Connect the power supply wires to the fan.

3. Install the front top profile of the cabinet in reverse order to step 1.
4. Fasten the back mounting screws of the roof.

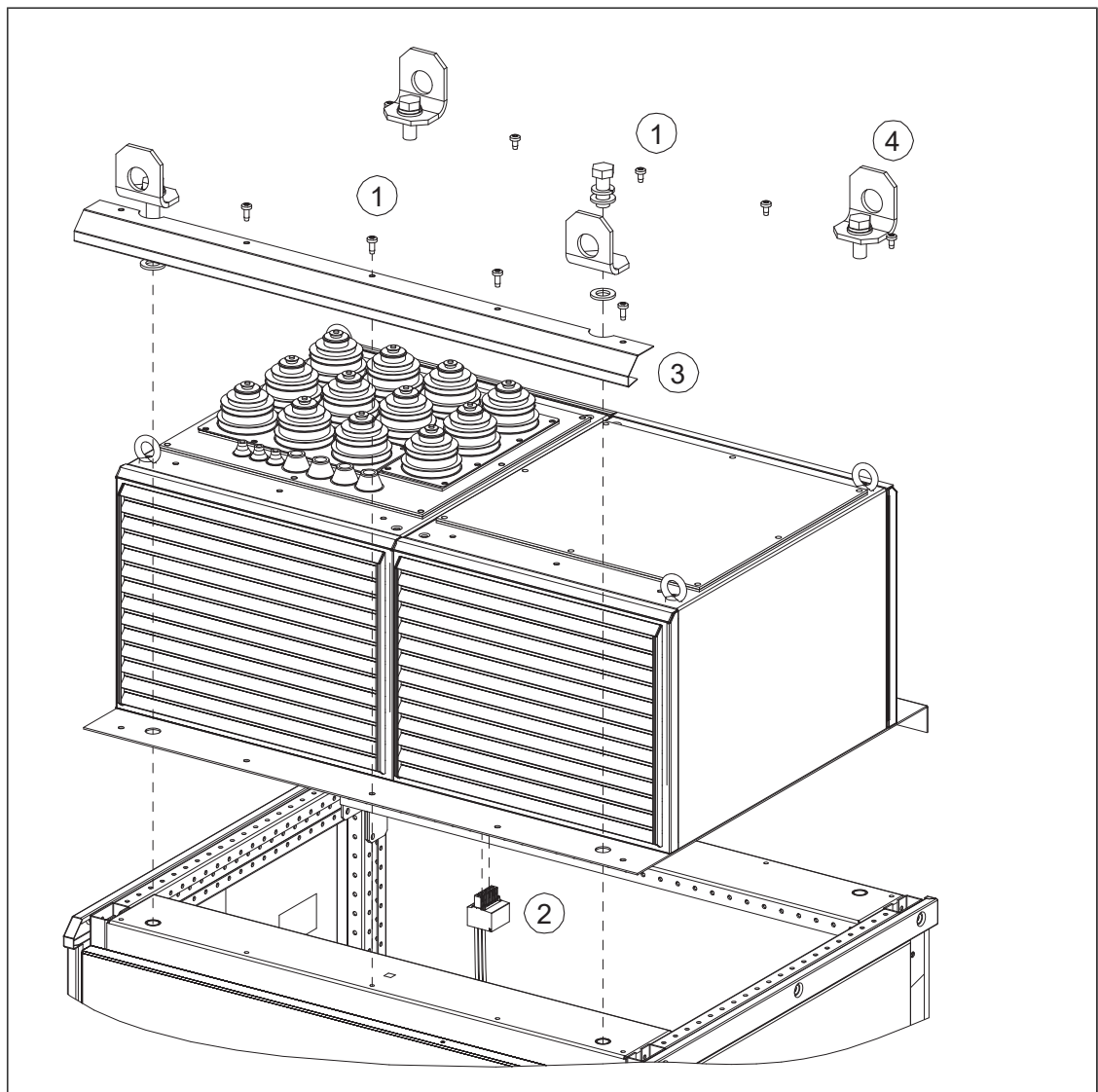

Attaching the cabinet to the floor and wall or roof

■ General rules

- The drive must be installed in an upright vertical position.
- Leave 400 mm (15.75") of free space above the basic roof level of the cabinet for cooling.
- The cabinet can be installed with its back against a wall (a), or back-to-back with another unit (b).
- Leave some space (w) at the side where the cabinet outmost hinges are to allow the doors to open sufficiently. The doors must open 120° to allow supply or inverter module drive module replacement.

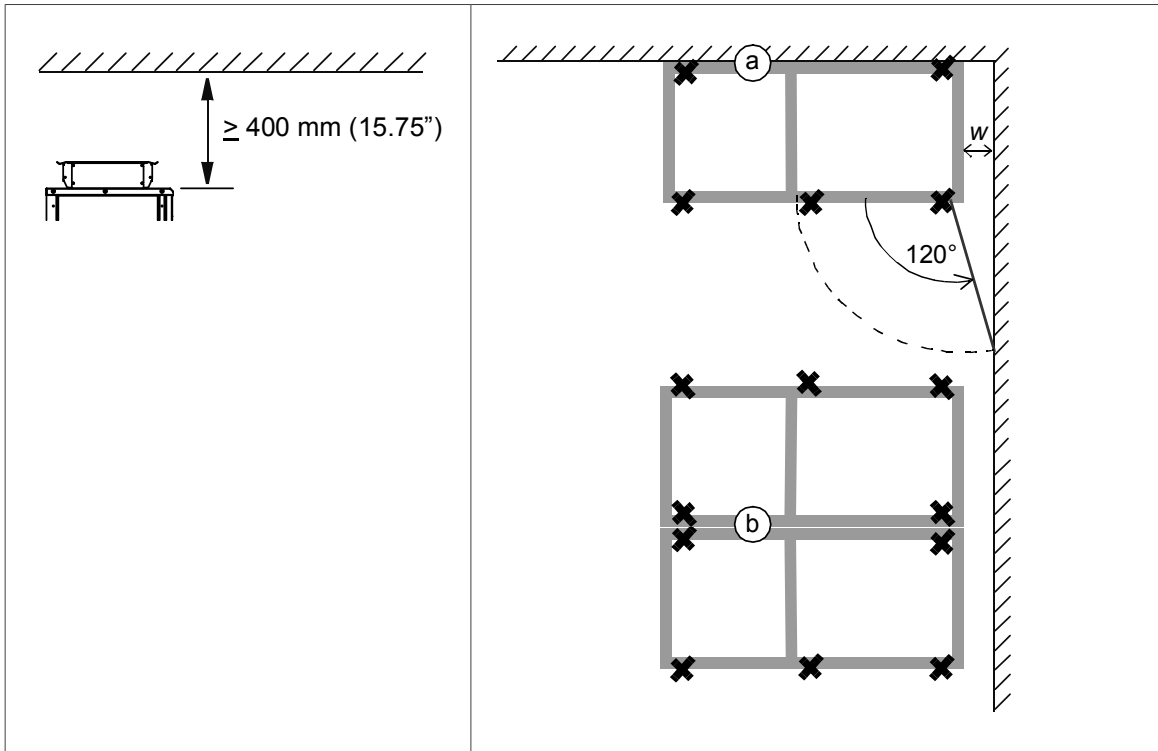

Note 1: Any height adjustment must be done before attaching the cabinet sections to the floor or to each other. Height adjustment can be done by using metal shims between the cabinet bottom and floor.

Note 2: Depending on the size of the cabinet, it has either bolt-on lifting eyes, or lifting bars with lifting holes. If the cabinet is delivered with lifting bars, remove them. Store the bars for decommissioning. Bolt-on lifting eyes need not be removed unless the holes are used for attaching the cabinet. Plug any unused holes using the existing bolts and sealing rings included. Tighten to 70 N·m (52 lbf·ft).

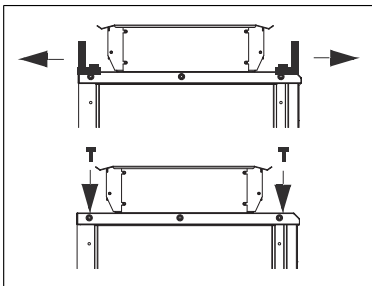

■ Attaching the cabinet (non-marine units)

Alternative 1 – Clamping

1. Insert the clamps (included) into the twin slots along the front and rear edges of the cabinet frame body and fasten them to the floor with a bolt. The recommended maximum distance between the clamps in the front edge is 800 mm (31.5”).
2. If floor mounting at the back is not possible, fasten the top of the cabinet to the wall with L-brackets (not included in the delivery) bolted to the lifting eye/bar holes, and suitable hardware.

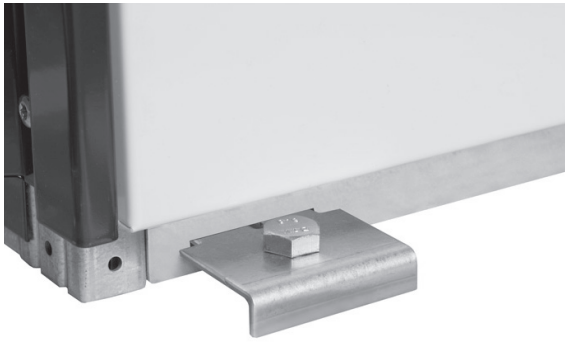
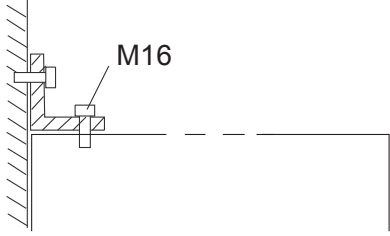
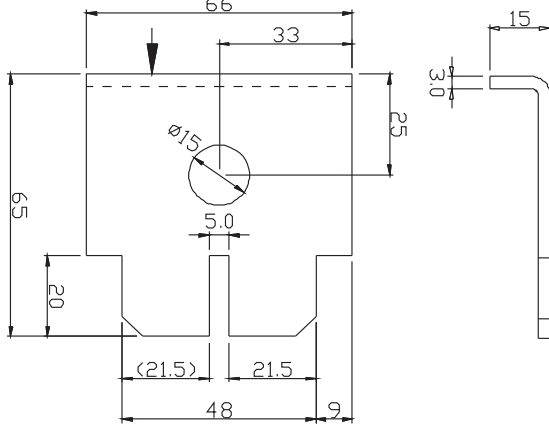
Clamping bottom to floor	Attaching top to wall
	
	

Alternative 2 – Using the holes inside the cabinet

1. Attach the cabinet to the floor through the bottom fastening holes with M10 to M12 (3/8" to 1/2") bolts. The recommended maximum distance between the front edge fastening points is 800 mm (31.5").
2. If the back fastening holes are not accessible, fasten the top of the cabinet to the wall with L-brackets (not included in the delivery) bolted to the lifting eye/bar holes.

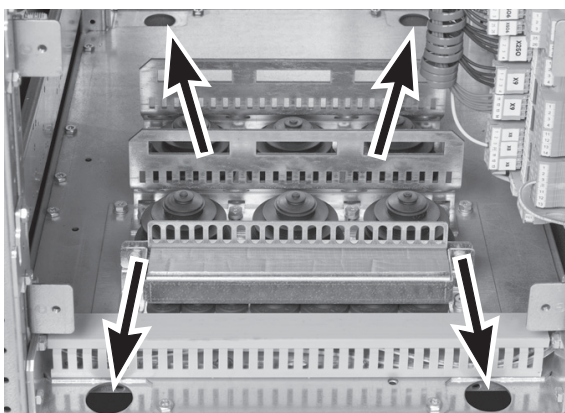
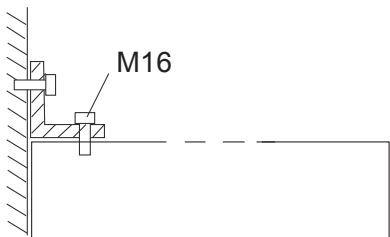
Attaching bottom to floor	Attaching cabinet top to wall
	



Alternative 3 – Cabinets with plinth options +C164 and +C179

Attach the plinth to the floor with the L-brackets with which the cabinet is attached to the transportation pallet.



■ **Attaching the cabinet (marine units)**

See the dimension drawing delivered with the drive for details of the fastening points.

Fasten the cabinet to the floor and roof (wall) as follows:

1. Bolt the unit to the floor through the flat bars at the base of the cabinet using M10 or M12 screws.
2. If there is not enough room behind the cabinet for installation, clamp (a) the rear edges of the flat bars (c) to the floor. See the figure below.
3. Attach corner brackets (d) to the lifting eye holes. Fasten the corner brackets to the rear wall and/or roof with suitable hardware such as U-brackets (e).

<p style="text-align: center;">②</p>	<p style="text-align: center;">③</p>
<p>a Clamp (not included)</p> <p>b Back panel of cabinet</p> <p>c Flat bars at base of cabinet</p>	<p>d Corner bracket (included)</p> <p>e U-bracket (not included)</p> <p>- -</p>



Miscellaneous

■ Cable duct in the floor below the cabinet

A cable duct can be constructed below the 500 mm wide middle part of the cabinet. The cabinet weight lies on the two 50 mm wide transverse sections which the floor must carry.

Prevent the cooling air flow from the cable duct to the cabinet by bottom plates. To ensure the degree of protection for the cabinet, use the original bottom plates delivered with the unit. With user-defined cable entries, take care of the degree of protection, fire protection and EMC compliance.

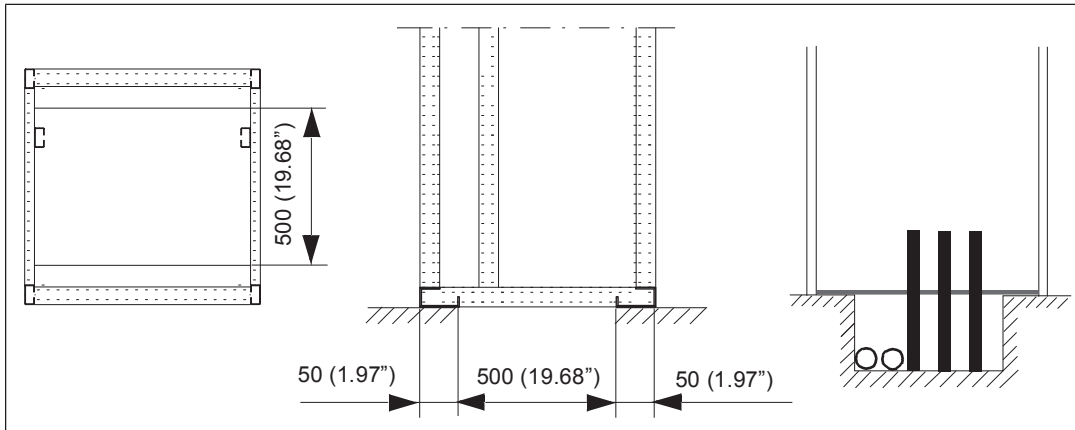

■ Arc welding

ABB does not recommend attaching the cabinet by arc welding. However, if arc welding is the only option, connect the return conductor of the welding equipment to the cabinet frame at the bottom within 0.5 meters (1'6") of the welding point.

Note: The cabinet frame is zinc-plated.



WARNING!

Make sure that the return wire is connected correctly. Welding current must not return via any component or cabling of the drive. If the welding return wire is connected improperly, the welding circuit can damage electronic circuits in the cabinet.



WARNING!

Do not inhale the welding fumes.

■ Air inlet through the bottom of cabinet (option +C128)

Drives with air intake through the bottom of the cabinet (option +C128) are intended for installation on an air duct in the floor.

An example of the air inlets in the cabinet bottom plate is shown below. Refer also to the dimension drawings delivered with the drive.

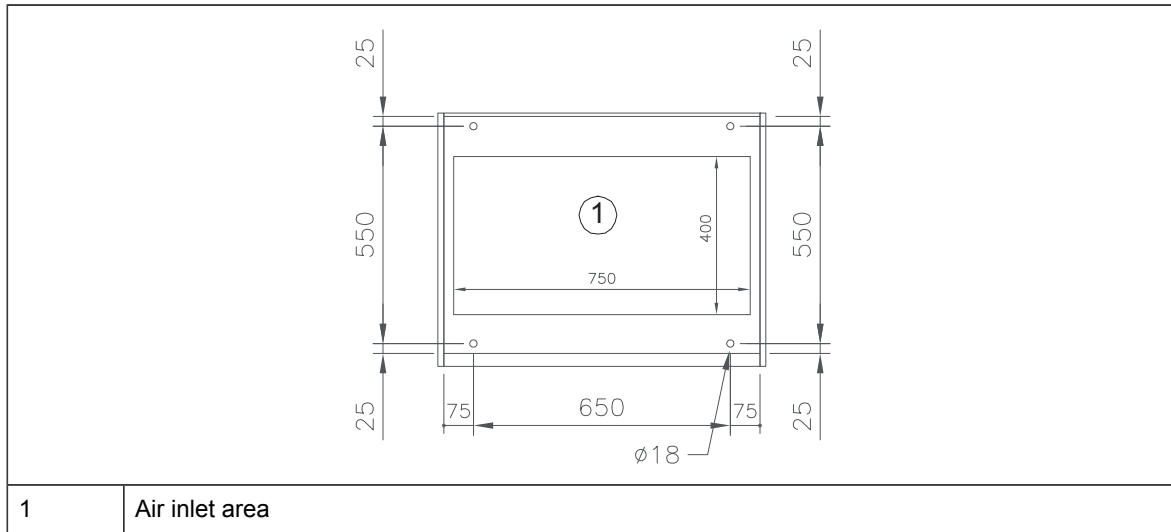

Support the plinth of the cabinet all round.

The air duct must be able to supply a sufficient volume of cooling air. See technical data for the minimum air flow values.



WARNING!

Make sure that the incoming air is sufficiently clean. If not, dust goes into the cabinet. The outlet filter on the cabinet roof prevents dust from going out. The collected dust can cause drive malfunction and danger of fire.

■ **Air outlet duct on the cabinet roof (option +C130)**

The option adds air outlet ducts to each cubicle of the cabinet line-up. The outlet diameter (and quantity) of the ducts depend on the cubicle width. The ducts used are from the Veloduct series by FläktGroup.

Cubicle width (mm)	Outlet duct				Channel
	Veloduct type	Outer diameter (mm)	Inner diameter (mm)	Cross-sectional area (m ²)	Recommended inner diameter (mm)
300	BDEA-6-020	200	194	0.030	200.0 ... 200.7
400	BDEA-6-031	310	304	0.073	315.0 ... 315.9
500	BDEA-6-031	310	304	0.073	315.0 ... 315.9
600	BDEA-6-040	400	394	0.122	400.0 ... 401.0
700	BDEA-6-040	400	394	0.122	400.0 ... 401.0
800	2 × BDEA-6-031	310	304	0.145	315.0 ... 315.9
1000	2 × BDEA-6-031	310	304	0.145	315.0 ... 315.9

The ventilation system must keep the static pressure in the air outlet duct sufficiently below the pressure of the room where the drive is located in order that the cabinet fans can produce the required air flow through the cabinet. Make sure that no dirty or moist air is able to flow backward to the drive in any case, even during off-time or while servicing the drive or the ventilation system.

Calculating the required static pressure difference

The required static pressure difference between the exit air duct and the drive installation room can be calculated as follows:

$$\Delta p_s = (1.5 \dots 2) \cdot p_d$$

where

$$p_d = 0.5 \cdot \rho \cdot v_m^2$$

$$v_m = q / A_c$$

p_d Dynamic pressure

ρ Air density (kg/m³)

v_m Average air velocity in the exit duct(s) (m/s)

q Rated air flow of the drive (m³/s)

A_c Cross-sectional area of the exit duct(s) (m²)

Example

The cabinet has 3 exit openings of 315 mm diameter. The rated air flow of the cabinet is 4650 m³/h = 1.3 m³/s.

$$A_c = 3 \cdot 0.315^2 \cdot \pi / 4 = 0.234 \text{ m}^2$$

$$v_m = 1.3 / 0.234 = 5.5 \text{ m/s}$$

$$p_d = 0.5 \cdot \rho \cdot v_m^2 = 0.5 \cdot 1.1 \cdot 5.5^2 = 17 \text{ Pa}$$

The required pressure in the exit air duct is then, $1.5 \dots 2 \cdot 17 \text{ Pa} = 26 \dots 34 \text{ Pa}$, below the pressure in the room.



5

Guidelines for planning the electrical installation

Contents of this chapter

This chapter contains instructions for planning the electrical installation of the drive. Some instructions are mandatory to follow in every installation, others provide useful information that only concerns certain applications.

Limitation of liability

The installation must always be designed and made according to applicable local laws and regulations. ABB does not assume any liability whatsoever for any installation which breaches the local laws and/or other regulations. Furthermore, if the recommendations given by ABB are not followed, the drive may experience problems that the warranty does not cover.

Selecting the supply disconnecting device

The drive is equipped with a main switch-disconnector as standard. The disconnector can be locked to the open position for installation and maintenance work.

Selecting the main contactor

The drive can be equipped with a line contactor (option +F250).

Examining the compatibility of the motor and drive

Use asynchronous AC induction motors, permanent magnet synchronous motors, AC induction servomotors or ABB synchronous reluctance motors (SynRM motors) with the drive.

Select the motor size and drive type from the rating table on basis of the AC line voltage and motor load. You can find the rating table in the appropriate hardware manual. You can also use the DriveSize PC tool.

Make sure that the motor can be used with an AC drive. See [Requirements table \(page 86\)](#). For basics of protecting the motor insulation and bearings in drive systems, see [Protecting the motor insulation and bearings \(page 86\)](#).

Note:

- Consult the motor manufacturer before using a motor whose nominal voltage differs from the AC line voltage connected to the drive input.
- The voltage peaks at the motor terminals are relative to the supply voltage of the drive, not the drive output voltage.

■ Protecting the motor insulation and bearings

The drive employs modern IGBT inverter technology. Regardless of frequency, the drive output comprises pulses of approximately the drive DC bus voltage with a very short rise time. The pulse voltage can almost double at the motor terminals, depending on the attenuation and reflection properties of the motor cable and the terminals. This can cause additional stress on the motor and motor cable insulation.

Modern variable speed drives with their fast rising voltage pulses and high switching frequencies can generate current pulses that flow through the motor bearings. This can gradually erode the bearing races and rolling elements.

du/dt filters protect motor insulation system and reduce bearing currents. Common mode filters mainly reduce bearing currents. Insulated N-end (non-drive end) bearings protect the motor bearings.

■ Requirements table

These tables show how to select the motor insulation system and when a drive du/dt and common mode filters and insulated N-end (non-drive end) motor bearings are required. Ignoring the requirements or improper installation may shorten motor life or damage the motor bearings and voids the warranty.

This table shows the requirements when an ABB motor is in use.

Motor type	Nominal AC line voltage	Requirement for			
		Motor insulation system	ABB du/dt and common mode filters, insulated N-end motor bearings		
			$P_n < 100$ kW and frame size < IEC 315	100 kW $\leq P_n < 350$ kW or IEC 315 \leq frame size < IEC 400	$P_n \geq 350$ kW or frame size \geq IEC 400
			$P_n < 134$ hp and frame size < NEMA 500	134 hp $\leq P_n < 469$ hp or NEMA 500 \leq frame size \leq NEMA 580	$P_n \geq 469$ hp or frame size > NEMA 580
Random-wound M2_, M3_ and M4_	$U_n \leq 500$ V	Standard	-	+ N	+ N + CMF
	500 V < $U_n \leq 600$ V	Standard	+ du/dt	+ N + du/dt	+ N + du/dt + CMF
		or			
	600 V < $U_n \leq 690$ V (cable length ≤ 150 m)	Reinforced	-	+ N	+ N + CMF
		Reinforced	+ du/dt	+ N + du/dt	+ N + du/dt + CMF
600 V < $U_n \leq 690$ V (cable length > 150 m)	Reinforced	-	+ N	+ N + CMF	
Form-wound HX_ and AM_	380 V < $U_n \leq 690$ V	Standard	n.a.	+ N + CMF	$P_n < 500$ kW: +N + CMF
					$P_n \geq 500$ kW: +N + du/dt + CMF
Old ¹⁾ form-wound HX_ and modular	380 V < $U_n \leq 690$ V	Check with the motor manufacturer.	+ N + du/dt with voltages over 500 V + CMF		
Random-wound HX_ and AM_ ²⁾	0 V < $U_n \leq 500$ V	Enamelled wire with fiber glass taping	+ N + CMF		
	500 V < $U_n \leq 690$ V		+ N + du/dt + CMF		
HDP	Consult the motor manufacturer.				

1) manufactured before 1.1.1998

2) For motors manufactured before 1.1.1998, check for additional instructions with the motor manufacturer.

This table shows the requirements when a non-ABB motor is in use.

Motor type	Nominal AC line voltage	Requirement for			
		Motor insulation system	ABB du/dt and common mode filters, insulated N-end motor bearings		
			$P_n < 100 \text{ kW}$ and frame size $< \text{IEC 315}$	$100 \text{ kW} \leq P_n < 350 \text{ kW}$ or $\text{IEC 315} \leq \text{frame size} < \text{IEC 400}$	$P_n \geq 350 \text{ kW}$ or frame size $\geq \text{IEC 400}$
$P_n < 134 \text{ hp}$ and frame size $< \text{NEMA 500}$	$134 \text{ hp} \leq P_n < 469 \text{ hp}$ or $\text{NEMA 500} \leq \text{frame size} \leq \text{NEMA 580}$	$P_n \geq 469 \text{ hp}$ or frame size $> \text{NEMA 580}$			
Random-wound and form-wound	$U_n \leq 420 \text{ V}$	Standard: $\hat{U}_{LL} = 1300 \text{ V}$	-	+ N or CMF	+ N + CMF
	$420 \text{ V} < U_n \leq 500 \text{ V}$	Standard: $\hat{U}_{LL} = 1300 \text{ V}$	+ du/dt	+ du/dt + (N or CMF)	+ N + du/dt + CMF
		or	Reinforced: $\hat{U}_{LL} = 1600 \text{ V}$, 0.2 micro-second rise time	-	+ N or CMF
	$500 \text{ V} < U_n \leq 600 \text{ V}$	Reinforced: $\hat{U}_{LL} = 1600 \text{ V}$	+ du/dt	+ du/dt + (N or CMF)	+ N + du/dt + CMF
		or	Reinforced: $\hat{U}_{LL} = 1800 \text{ V}$	-	+ N or CMF
	$600 \text{ V} < U_n \leq 690 \text{ V}$	Reinforced: $\hat{U}_{LL} = 1800 \text{ V}$	+ du/dt	+ du/dt + N	+ N + du/dt + CMF
		Reinforced: $\hat{U}_{LL} = 2000 \text{ V}$, 0.3 micro-second rise time ¹⁾	-	+ N + CMF	+ N + CMF

¹⁾ If the intermediate DC circuit voltage of the drive is increased from the nominal level due to long term resistor braking cycles, check with the motor manufacturer if additional output filters are needed.

The abbreviations used in the tables are defined below.

Abbr.	Definition
U_n	Nominal AC line voltage
\hat{U}_{LL}	Peak line-to-line voltage at motor terminals which the motor insulation must withstand
P_n	Motor nominal power
du/dt	du/dt filter at the output of the drive
CMF	Common mode filter of the drive
N	N-end bearing: insulated motor non-drive end bearing
n.a.	Motors of this power range are not available as standard units. Consult the motor manufacturer.

Availability of du/dt filter and common mode filter by drive type

TO BE ADDED

Additional requirements for explosion-safe (EX) motors

If you will use an explosion-safe (EX) motor, follow the rules in the requirements table above. In addition, consult the motor manufacturer for any further requirements.

Additional requirements for ABB motors of types other than M2_, M3_, M4_, HX_ and AM_

Use the selection criteria given for non-ABB motors.

Additional requirements for ABB high-output and IP23 motors

The rated output power of high output motors is higher than what is stated for the particular frame size in EN 50347 (2001).

This table shows the requirements for protecting the motor insulation and bearings in drive systems for ABB random-wound motor series (for example, M3AA, M3AP and M3BP).

Nominal AC supply voltage	Requirement for			
	Motor insulation system	ABB du/dt and common mode filters, insulated N-end motor bearings		
		$P_n < 100 \text{ kW}$	$100 \text{ kW} \leq P_n < 200 \text{ kW}$	$P_n \geq 200 \text{ kW}$
		$P_n < 140 \text{ hp}$	$140 \text{ hp} \leq P_n < 268 \text{ hp}$	$P_n \geq 268 \text{ hp}$
$U_n \leq 500 \text{ V}$	Standard	-	+ N	+ N + CMF
$500 \text{ V} < U_n \leq 600 \text{ V}$	Standard	+ du/dt	+ du/dt + N	+ du/dt + N + CMF
	or			
$600 \text{ V} < U_n \leq 690 \text{ V}$	Reinforced	-	+ N	+ N + CMF
	Reinforced	+ du/dt	+ du/dt + N	+ du/dt + N + CMF

Additional requirements for non-ABB high-output and IP23 motors

The rated output power of high-output motors is higher than what is stated for the particular frame size in EN 50347 (2001).

If you plan to use a non-ABB high-output motor or an IP23 motor, consider these additional requirements for protecting the motor insulation and bearings in drive systems:

- If motor power is below 350 kW: Equip the drive and/or motor with the filters and/or bearings according to the table below.
- If motor power is above 350 kW: Consult the motor manufacturer.

Nominal AC supply voltage	Requirement for		
	Motor insulation system	ABB du/dt and common mode filters, insulated N-end motor bearings	
		$P_n < 100 \text{ kW}$ or frame size < IEC 315	$100 \text{ kW} < P_n < 350 \text{ kW}$ or IEC 315 < frame size < IEC 400
	$P_n < 134 \text{ hp}$ or frame size < NEMA 500	$134 \text{ hp} < P_n < 469 \text{ hp}$ or NEMA 500 < frame size < NEMA 580	
$U_n \leq 420 \text{ V}$	Standard: $\hat{U}_{LL} = 1300 \text{ V}$	+ N or CMF	+ N or CMF
$420 \text{ V} < U_n < 500 \text{ V}$	Standard: $\hat{U}_{LL} = 1300 \text{ V}$	+ du/dt + (N or CMF)	+ N + du/dt + CMF
	or Reinforced: $\hat{U}_{LL} = 1600 \text{ V}$, 0.2 microsecond rise time	+ N or CMF	+ N or CMF
$500 \text{ V} < U_n \leq 600 \text{ V}$	Reinforced: $\hat{U}_{LL} = 1600 \text{ V}$	+ du/dt + (N or CMF)	+ N + du/dt + CMF
	or Reinforced: $\hat{U}_{LL} = 1800 \text{ V}$	+ N or CMF	+ N + CMF
$600 \text{ V} < U_n \leq 690 \text{ V}$	Reinforced: $\hat{U}_{LL} = 1800 \text{ V}$	+ N + du/dt	+ N + du/dt + CMF
	Reinforced: $\hat{U}_{LL} = 2000 \text{ V}$, 0.3 microsecond rise time ¹⁾	+ N + CMF	+ N + CMF

¹⁾ If the intermediate DC circuit voltage of the drive is increased from the nominal level due to long term resistor braking cycles, check with the motor manufacturer if additional output filters are needed.

Additional data for calculating the rise time and the peak line-to-line voltage

The diagrams below show the relative peak line-to-line voltage and rate of change of voltage as a function of the motor cable length. If you need to calculate the actual peak voltage and voltage rise time considering the actual cable length, proceed as follows:

- Peak line-to line voltage: Read the relative \hat{U}_{LL}/U_n value from the diagram below and multiply it by the nominal supply voltage (U_n).
- Voltage rise time: Read the relative values \hat{U}_{LL}/U_n and $(du/dt)/U_n$ from the diagram below. Multiply the values by the nominal supply voltage (U_n) and substitute into equation $t = 0.8 \cdot \hat{U}_{LL}/(du/dt)$.

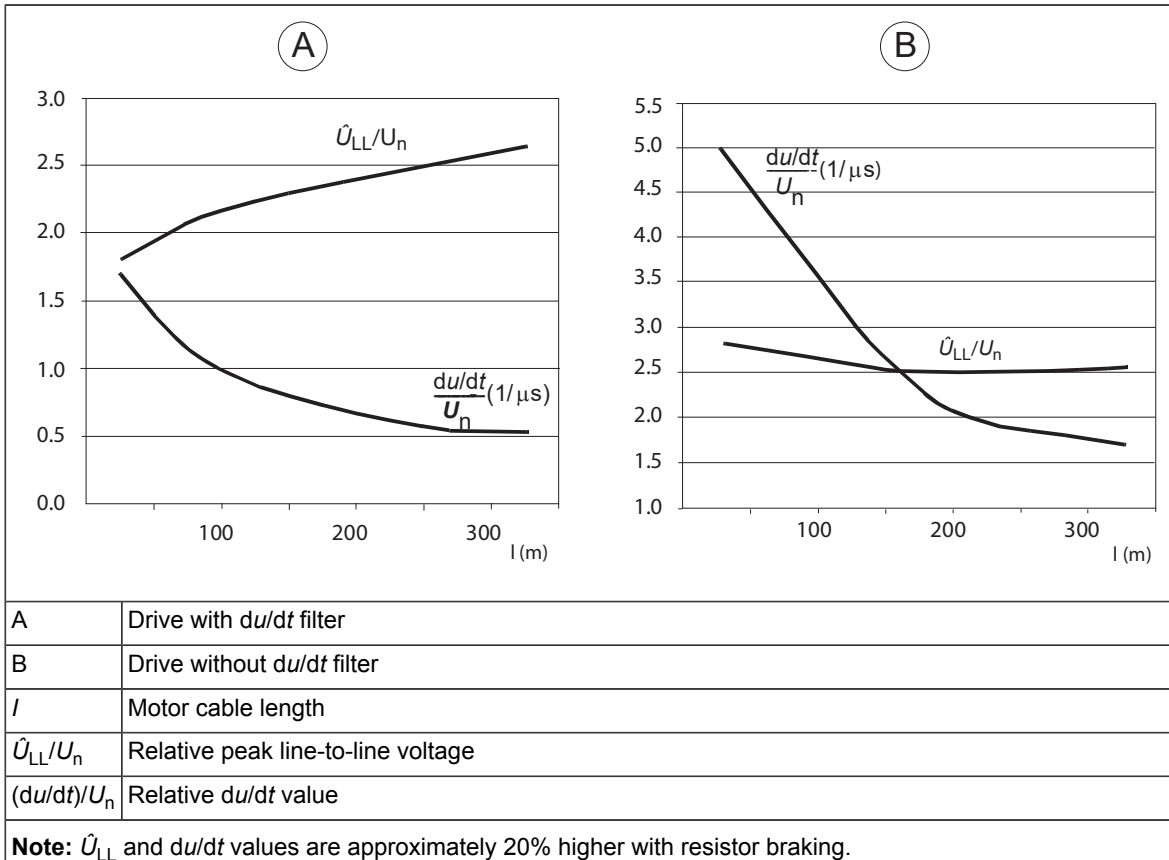

Additional note for sine filters

A sine filter also protects the motor insulation system. The peak phase-to-phase voltage with a sine filter is approximately $1.5 \cdot U_n$.

Selecting the power cables

■ General guidelines

Select the input power and motor cables according to local regulations.

- **Current:** Select a cable capable of carrying the maximum load current and suitable for the prospective short-circuit provided by the supply network. The method of installation and ambient temperature affect the cable current carrying capacity. Obey local regulations and laws.
- **Temperature:** For an IEC installation, select a cable rated for at least 70 °C (158 °F) maximum permissible temperature of conductor in continuous use. For North America, select a cable rated for at least 75 °C (167 °F).
- **Voltage:** 600 V AC cable is accepted for up to 500 V AC. 750 V AC cable is accepted for up to 600 V AC. 1000 V AC cable is accepted for up to 690 V AC.

To comply with the EMC requirements of the CE mark, use one of the preferred cable types. See [Preferred power cable types \(page 92\)](#).

Symmetrical shielded cable reduces electromagnetic emission of the whole drive system as well as the stress on motor insulation, bearing currents and wear.

Metal conduit reduces electromagnetic emission of the whole drive system.

The protective conductor must always have an adequate conductivity.

Unless local wiring regulations state otherwise, the cross-sectional area of the protective conductor must agree with the conditions that require automatic disconnection of the supply required in 411.3.2. of IEC 60364-4-41:2005 and be capable of withstanding the prospective fault current during the disconnection time of the protective device. The cross-sectional area of the protective conductor can either be selected from the table below or calculated according to 543.1 of IEC 60364-5-54.

This table shows the minimum cross-sectional area of the protective conductor related to the phase conductor size according to IEC/UL 61800-5-1 when the phase conductor and the protective conductor are made of the same metal. If this is not so, the cross-sectional area of the protective grounding conductor shall be determined in a manner which produces a conductance equivalent to that which results from the application of this table.

Cross-sectional area of the phase conductors S (mm ²)	Minimum cross-sectional area of the corresponding protective conductor S _p (mm ²)
S ≤ 16	S ¹⁾
16 < S ≤ 35	16
35 < S	S/2

1) To comply with standard IEC/EN 61800-5-1 (UL 61800-5-1)

- use a protective earth conductor with a minimum cross-sectional area of 10 mm² Cu or 16 mm² Al (as an alternative when aluminum cables are permitted),
or
- use a second protective earth conductor of the same cross-sectional area as the original protective earth conductor,
or
- use a device that automatically disconnects the supply if the protective earth conductor is damaged.

If the protective earth conductor is separate (that is, it does not form part of the input power cable or the input power cable enclosure), the minimum cross-sectional area must be:

- 2.5 mm² when the conductor is mechanically protected,
or
- 4 mm² when the conductor is not mechanically protected.

■ Typical power cable sizes

See the technical data.

■ Power cable types

Preferred power cable types

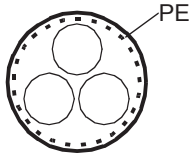

This section presents the preferred cable types. Make sure that the selected cable type also complies with local/state/country electrical codes.

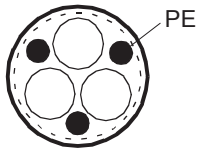
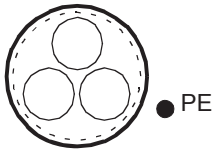

Cable type	Use as input power cabling	Use as motor cabling
 <p>Symmetrical shielded (or armored) cable with three phase conductors and concentric PE conductor as shield (or armor)</p>	Yes	Yes

Cable type	Use as input power cabling	Use as motor cabling
 <p>Symmetrical shielded (or armored) cable with three phase conductors and symmetrically constructed PE conductor and a shield (or armor)</p>	Yes	Yes
 <p>Symmetrical shielded (or armored) cable with three phase conductors and a shield (or armor), and separate PE conductor/cable¹⁾</p>	Yes	Yes

¹⁾ A separate PE conductor is required if the conductivity of the shield (or armor) is not sufficient for the PE use.

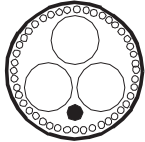
Alternate power cable types

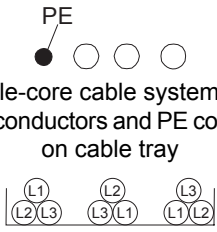
Cable type	Use as input power cabling	Use as motor cabling
 <p>Four-conductor cabling in PVC conduit or jacket (three phase conductors and PE)</p>	Yes with phase conductor smaller than 10 mm ² (8 AWG) Cu.	Yes with phase conductor smaller than 10 mm ² (8 AWG) Cu, or motors up to 30 kW (40 hp). Note: Shielded or armored cable, or cabling in metal conduit is always recommended to minimize radio frequency interference.
 <p>Four-conductor cabling in metal conduit (three phase conductors and PE), eg, EMT, or four-conductor armored cable</p>	Yes	Yes with phase conductor smaller than 10 mm ² (8 AWG) Cu, or motors up to 30 kW (40 hp)
 <p>Shielded (Al/Cu shield or armor)¹⁾ four-conductor cable (three phase conductors and a PE)</p>	Yes	Yes with motors up to 100 kW (135 hp). A potential equalization between the frames of motor and driven equipment is required.

Cable type	Use as input power cabling	Use as motor cabling
 <p>A single-core cable system: three phase conductors and PE conductor on cable tray</p> <p>Preferable cable arrangement to avoid voltage or current imbalance between the phases</p>	<p>Yes</p>  <p>WARNING! If you use unshielded single-core cables in an IT network, make sure that the non-conductive outer sheath (jacket) of the cables have good contact with a properly grounded conductive surface. For example, install the cables on a properly grounded cable tray. Otherwise voltage may become present on the non-conductive outer sheath of the cables, and there is even a risk of an electric shock.</p>	No

1) Armor may act as an EMC shield, as long as it provides the same performance than a concentric EMC shield of a shielded cable. To be effective at high frequencies, the shield conductivity must be at least 1/10 of the phase conductor conductivity. The effectiveness of the shield can be evaluated based on the shield inductance, which must be low and only slightly dependent on frequency. The requirements are easily met with a copper or aluminum shield/armor. Cross-section of a steel shield has to be ample and the shield helix low gradient. Galvanizing increases the high-frequency conductivity.

Not allowed power cable types

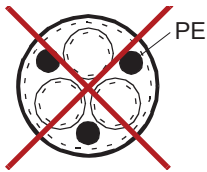
Cable type	Use as input power cabling	Use as motor cabling
 <p>Symmetrical shielded cable with individual shields for each phase conductor</p>	No	No

■ **Additional guidelines, North America**

ABB recommends the use of conduit for power wiring to the drive and between the drive and the motor(s). Due to the variety of application needs, metallic and non-metallic conduit can be used. ABB recommends the use of metallic conduit.

The following table shows examples of various materials and methods for wiring the drive in the intended application. See NEC 70 along with state and local codes for the appropriate materials for your application.

In all applications, ABB prefers the use of symmetrical shielded VFD cable between drive and motor(s).

Wiring method	Notes
Conduit - Metallic ^{1) 2)}	
Electrical metallic tubing: Type EMT	Prefer symmetrical shielded VFD cable.
Rigid metal conduit: Type RMC	Use separate conduit run for each motor.
Liquid-tight flexible metal electrical conduit: Type LFMC	Do not run input power wiring and motor wiring in the same conduit.
Conduit - Non-metallic ^{2) 3)}	
Liquid-tight flexible non-metallic conduit: Type LFNC	Prefer symmetrical shielded VFD cable. Use separate conduit run for each motor. Do not run input power wiring and motor wiring in the same conduit.
Wireways ²⁾	
Metallic	Prefer symmetrical shielded VFD cable. Separate motor wiring from input power wiring and other low voltage wiring. Do not run outputs of multiple drives parallel. Bundle each cable (wiring) together and use separators where possible.
Free air ²⁾	
Enclosures, air handlers, etc.	Prefer symmetrical shielded VFD cable. Allowed internally in enclosures when in accordance with UL.

1) Metallic conduit may be used as an additional ground path, provided this path is a solid path capable of handling ground currents.

2) See NFPA NEC 70, UL, and local codes for your application.

3) Non-metallic conduit use underground is allowed; however, these installations inherently have an increased chance for nuisance problems due to the potential for water/moisture in the conduit. Water/moisture in the conduit increases the likelihood of VFD faults or warnings. Proper installation is required to make sure there is no intrusion of water/moisture.

Metal conduit

Couple separate parts of a metal conduit together: bridge the joints with a ground conductor bonded to the conduit on each side of the joint. Also bond the conduits to the drive enclosure and motor frame. Use separate conduits for input power, motor, brake resistor, and control wiring. Do not run motor wiring from more than one drive in the same conduit.

■ Power cable shield

If the cable shield is used as the sole protective earth (PE) conductor, make sure that its conductivity agrees with the PE conductor requirements.

To effectively suppress radiated and conducted radio-frequency emissions, the cable shield conductivity must be at least 1/10 of the phase conductor conductivity. The requirements are easily met with a copper or aluminum shield. The minimum requirement of the motor cable shield of the drive is shown below. It consists of a concentric layer of copper wires with an open helix of copper tape or copper wire. The better and tighter the shield, the lower the emission level and bearing currents.

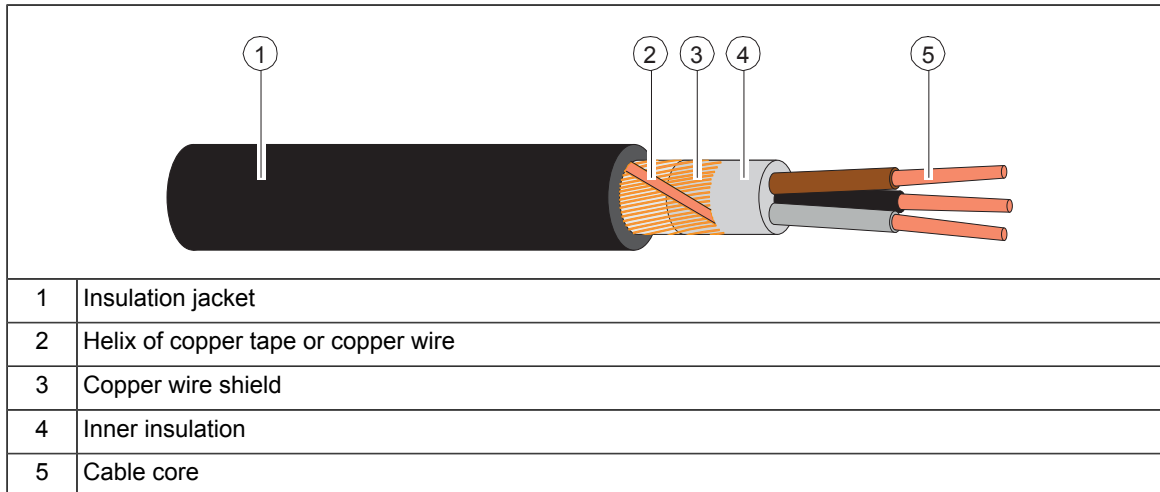

Planning the resistor braking system

See chapter [Resistor braking \(page 261\)](#)

Selecting the control cables

■ Shielding

Only use shielded control cables.

Use a double-shielded twisted pair cable for analog signals. This type of cable is recommended for the pulse encoder signals also. Use one individually shielded pair for each signal. Do not use common return for different analog signals.

A double-shielded cable (a) is the best alternative for low-voltage digital signals, but single-shielded (b) twisted pair cable is also acceptable.

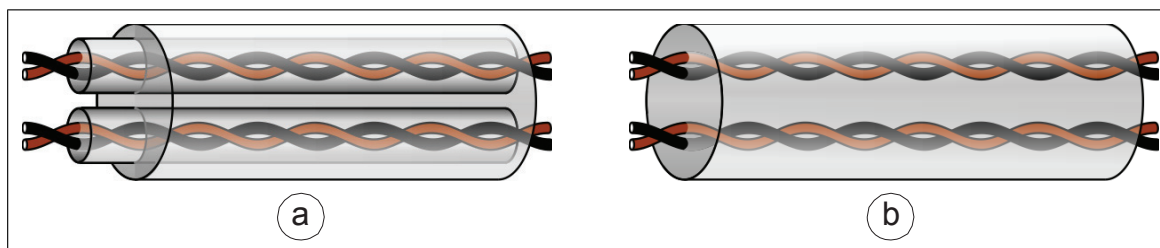

■ Signals in separate cables

Run analog and digital signals in separate, shielded cables. Do not mix 24 V DC and 115/230 V AC signals in the same cable.

■ Signals that can be run in the same cable

If their voltage does not exceed 48 V, relay-controlled signals can be run in the same cables as digital input signals. The relay-controlled signals should be run as twisted pairs.

■ Relay cable

The cable type with braided metallic shield (for example ÖLFLEX by LAPPKABEL, Germany) has been tested and approved by ABB.

■ **Control panel to drive cable**

Use EIA-485 with male RJ-45 connector, cable type Cat 5e or better. The maximum permitted length of the cable is 100 m (328 ft).

■ **PC tool cable**

Connect the Drive composer PC tool to the drive through the USB port of the control panel. Use a USB Type A (PC) - Type Mini-B (control panel) cable. The maximum length of the cable is 3 m (9.8 ft).

Routing the cables

■ **General guidelines – IEC**

- Route the motor cable away from other cables. Motor cables of several drives can be run in parallel installed next to each other.
- Install the motor cable, input power cable and control cables on separate trays.
- Avoid long parallel runs of motor cables with other cables.
- Where control cables must cross power cables, make sure that they are arranged at an angle as near to 90 degrees as possible.
- Do not run extra cables through the drive.
- Make sure that the cable trays have good electrical bonding to each other and to the grounding electrodes. Aluminum tray systems can be used to improve local equalizing of potential.

The following figure illustrates the cable routing guidelines with an example drive.

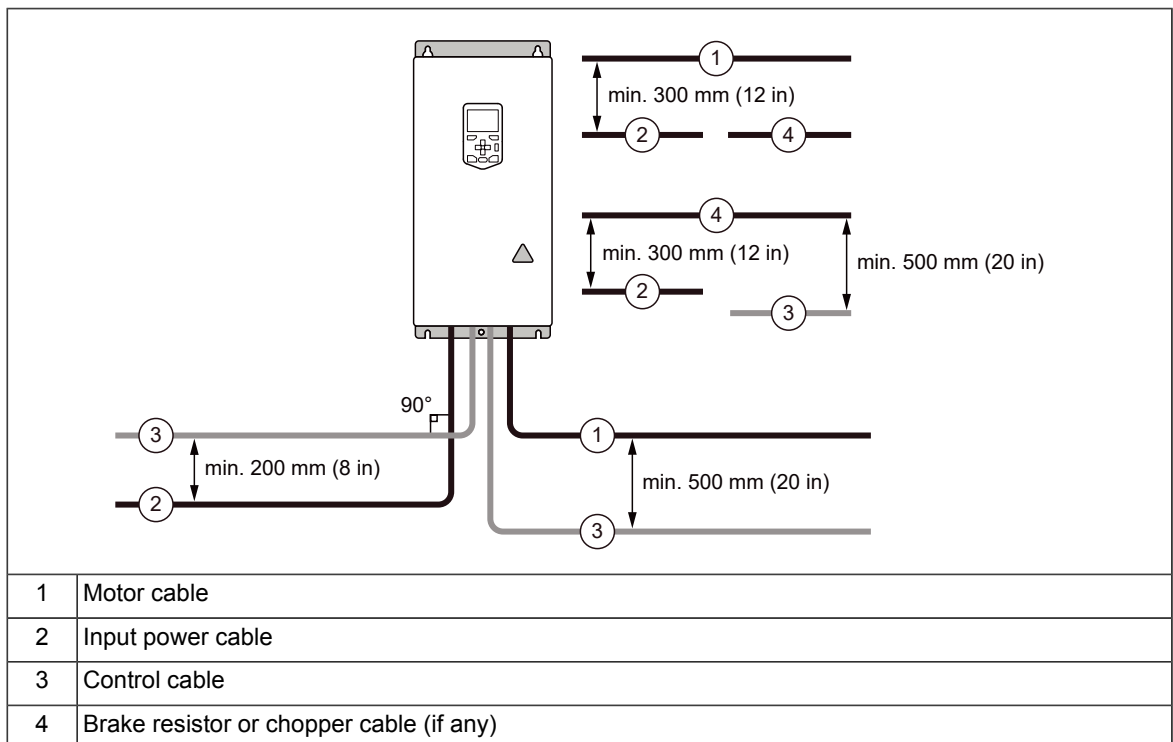

■ General guidelines – North America

Make sure that the installation is in accordance with national and local codes. Obey these general guidelines:

- Use separate conduits for the input power, motor, brake resistor (optional), and control cabling.
- Use separate conduit for each motor cabling.

The following figure illustrates the cable routing guidelines with an example drive.

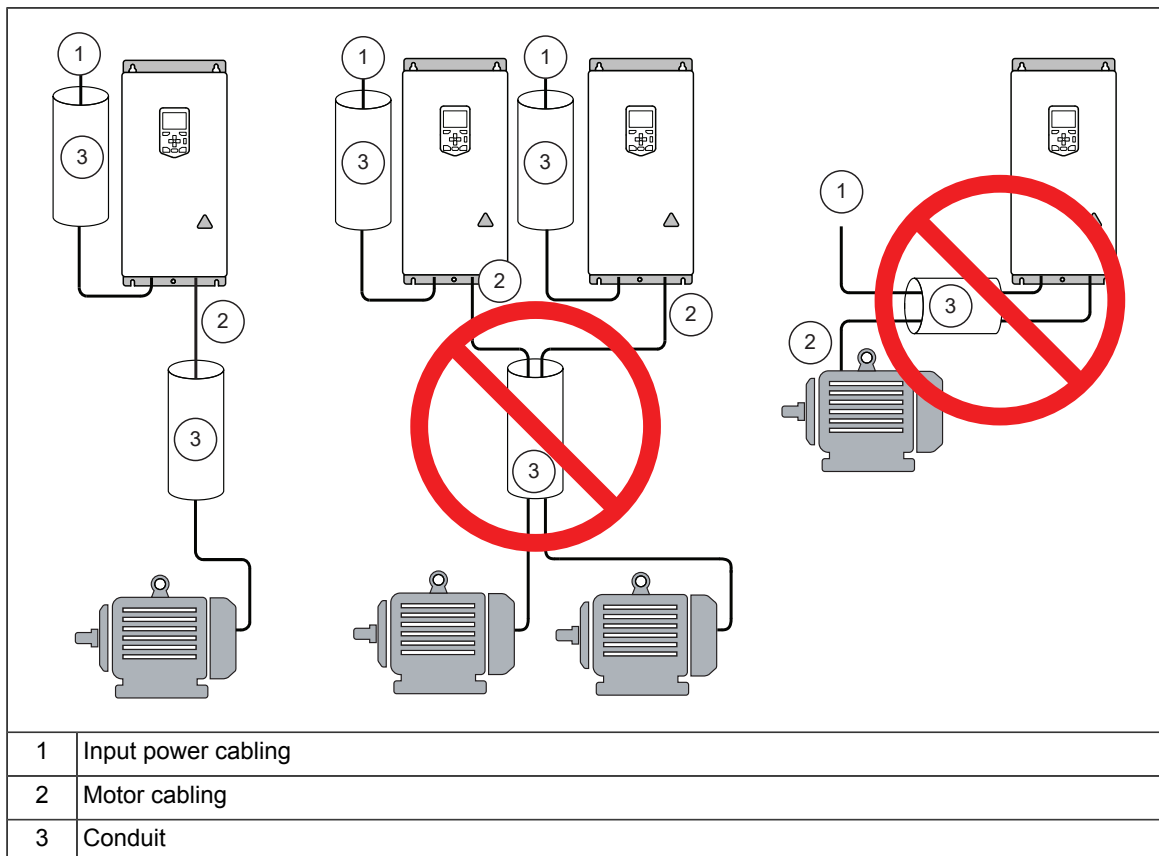

■ Continuous motor cable shield/conduit or enclosure for equipment on the motor cable

To minimize the emission level when safety switches, contactors, connection boxes or similar equipment are installed on the motor cable between the drive and the motor:

- Install the equipment in a metal enclosure.
- Use either a symmetrical shielded cable, or install the cabling in a metal conduit.
- Make sure that there is a good and continuous galvanic connection in the shield/conduit between drive and motor.
- Connect the shield/conduit to the protective ground terminal of the drive and the motor.

■ **Separate control cable ducts**

Put 24 V DC and 230 V AC (120 V AC) control cables in separate ducts, unless the 24 V DC cable is insulated for 230 V AC (120 V AC) or insulated with an insulation sleeving for 230 V AC (120 V AC).

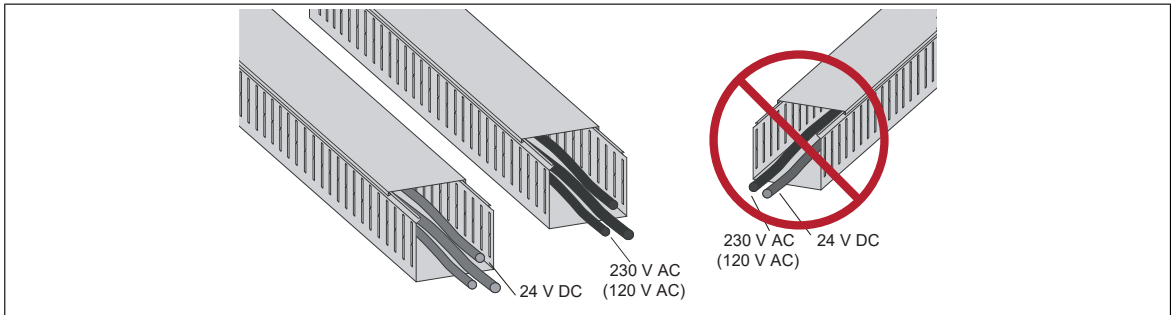

Protecting the drive, input power cable, motor and motor cable in short circuit situations and against thermal overload

■ **Protecting the drive and input power cable in short-circuit situations**

The drive is equipped with internal AC fuses (1) as standard. The fuses restrict drive damage and prevent damage to adjoining equipment in case of a short-circuit inside the drive.

Protect the input cable with fuses or circuit breaker (2) according to local safety regulations, appropriate input voltage and the rated current of the drive (see chapter *Technical data (page 197)*).

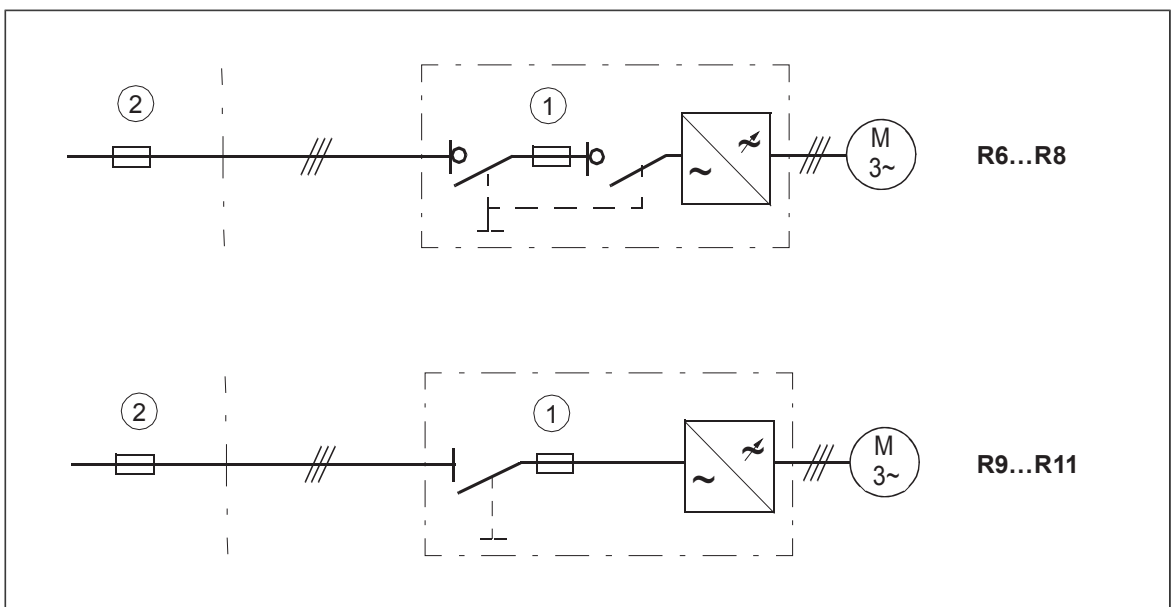

■ **Protecting the motor and motor cable in short-circuits**

The drive protects the motor cable and motor in a short-circuit situation when the motor cable is sized according to the nominal current of the drive. No additional protection devices are needed.

■ Protecting the drive and the power cables against thermal overload

The drive protects itself and the input and motor cables against thermal overload when the cables are sized according to the nominal current of the drive. No additional thermal protection devices are needed.



WARNING!

If the drive is connected to multiple motors, use a separate circuit breaker or fuses for protecting each motor cable and motor against overload. The drive overload protection is tuned for the total motor load. It may not trip due to an overload in one motor circuit only.

■ Protecting the motor against thermal overload

According to regulations, the motor must be protected against thermal overload and the current must be switched off when overload is detected. The drive includes a motor thermal protection function that protects the motor and switches off the current when necessary. Depending on a drive parameter value, the function either monitors a calculated temperature value (based on a motor thermal model) or an actual temperature indication given by motor temperature sensors.

The motor thermal protection model supports thermal memory retention and speed sensitivity. The user can tune the thermal model further by feeding in additional motor and load data.

The most common temperature sensor types are PTC or Pt100.

For more information, see the firmware manual.

■ Protecting the motor against overload without thermal model or temperature sensors

Motor overload protection protects the motor against overload without using motor thermal model or temperature sensors.

Motor overload protection is required and specified by multiple standards including the US National Electric Code (NEC) and the common UL/IEC 61800-5-1 standard in conjunction with IEC 60947-4-1. The standards allow for motor overload protection without external temperature sensors.

The protection feature allows the user to specify the class of operation in the same manner as the overload relays are specified in standards IEC 60947-4-1 and NEMA ICS 2.

The motor overload protection supports thermal memory retention and speed sensitivity.

For more information, see drive firmware manual.

Protecting the drive against ground faults

The drive is equipped with an internal ground fault protective function to protect the unit against ground faults in the motor and motor cable. This function is not a personnel safety or a fire protection feature. See the firmware manual for more information.

An optional ground fault monitoring device (+Q954) is available for IT (ungrounded) systems. The option includes a ground fault indicator on the drive cabinet door.

■ Residual current device compatibility

The drive is suitable to be used with residual current devices of Type B.

Note: As standard, the drive contains capacitors connected between the main circuit and the frame. These capacitors and long motor cables increase the ground leakage current and may cause nuisance faults in residual current devices.

Implementing the emergency stop function

You can order the drive with an emergency stop function (option).

See the appropriate option manual for more information.

Option code	User's manual	Manual code (English)
+Q951	Emergency stop, stop category 0 (using main contactor/breaker)	3AUA0000119895
+Q952	Emergency stop, stop category 1 (using main contactor/breaker)	3AUA0000119896
+Q963	Emergency stop, stop category 0 (using Safe torque off)	3AUA0000119908
+Q964	Emergency stop, stop category 1 (using Safe torque off)	3AUA0000119909
+Q978	Emergency stop, stop category 0 or 1 (using main contactor/breaker and Safe torque off)	3AUA0000145920
+Q979	Emergency stop, stop category 0 or 1 (using Safe torque off)	3AUA0000145921

Implementing the Safe torque off function

See chapter *The Safe torque off function (page 245)*.

Implementing the Prevention of unexpected start-up function

You can order the drive with a Prevention of unexpected start-up (POUS) function. The POUS function disables the control voltage of the power semiconductors of the drive (inverter) output stage. This prevents the drive from generating the torque required to rotate the motor. POUS enables a short-time maintenance work (like cleaning) on the non-electrical parts of the machinery without switching off and disconnecting the drive.

See the appropriate option manual for more information.

Option code	User's manual	Manual code (English)
+Q950	Prevention of unexpected start-up, with FSO-xx safety functions module	3AUA0000145922
+Q957	Prevention of unexpected start-up, with safety relay	3AUA0000119910

Implementing an ATEX-certified motor thermal protection

With option +Q971, the drive provides ATEX-certified safe motor disconnection without contactor using the drive Safe torque off function. To implement the thermal protection of a motor in explosive atmosphere (Ex motor), you must also:

- use an ATEX-certified Ex motor
 - order an ATEX-certified thermistor protection module for the drive (option +L357), or acquire and install an ATEX-compliant protection relay
 - do the necessary connections.
-

For a cabinet-installed drives, an ATEX-certified motor thermal protection function is also available (option +L513+Q971, or +L514+Q971). The drive is equipped with an ATEX-certified Safe motor disconnection function and with an ATEX-compliant protection relay, either for PTC, or Pt100 temperature sensors.

For more information, see:

User's manual	Manual code (English)
<i>ATEX-certified Safe disconnection function, Ex II (2) GD for ACS880 drives (+Q971) application guide</i>	3AUA0000132231
<i>FPTC-02 ATEX-certified thermistor protection module, Ex II (2) GD (option +L537+Q971) for ACS880 drives user's manual</i>	3AXD50000027782
<i>ATEX-certified motor thermal protection functions for cabinet-built ACS880 drives (options +L513+Q971 and +L514+Q971) user's manual</i>	3AXD50000014979

Implementing the functions provided by the FSO-xx safety functions module

You can order the drive with an FSO-12 or FSO-21 safety functions module (option +Q972 or +Q973) which enables the implementation of functions such as Safe brake control (SBC), Safe stop 1 (SS1), Safe stop emergency (SSE), Safely limited speed (SLS) and Safe maximum speed (SMS).

The settings of the FSO-xx module have default values when delivered from the factory. The wiring of the external safety circuit and configuration of the FSO-xx module are the responsibility of the user.

The FSO-xx module reserves the standard Safe torque off (STO) connection of the drive control unit. STO can still be utilized by other safety circuits through the FSO-xx.

See the appropriate manual for more information.

Name	Code
<i>FSO-12 safety functions module user's manual</i>	3AXD50000015612
<i>FSO-21 safety functions module user's manual</i>	3AXD50000015614

Implementing the power loss ride-through function

If the incoming supply voltage is cut off, the drive will continue to operate by utilizing the kinetic energy of the rotating motor. The drive will be fully operational as long as the motor rotates and generates energy to the drive.

If the drive is equipped with a main contactor (option +F250), it restores the drive input power after a short break. The power supply for the contactor control circuit is buffered. It keeps the contactor closed in short power-loss situations. If the drive is equipped an external uninterruptible auxiliary power supply (option +G307), it keeps the main contactor closed in power-loss situations.

Note that if the power loss lasts so long that the drive trips on undervoltage, a fault reset and a fresh start command is required to continue operation.

Implement the power-loss ride-through function as follows:

1. Enable the power-loss ride-through function of the drive (parameter 30.31).
2. Enable the automatic restart of the motor after a short power supply break:
 - Set the start mode to automatic (parameter 21.01 or 21.19, depending on the motor control mode being used).
 - Define the automatic restart time (parameter 21.18).



WARNING!

Make sure that a flying restart of the motor will not cause any danger. If you are in doubt, do not implement the power loss ride-through function.

Supplying power for the auxiliary circuits

The user must supply these options from external power sources:

- +G300/+G301: Cabinet heaters and/or lighting (230 or 115 V AC; external fuse: 16 A gG)
- +G307: Connection for an external uninterruptible power supply (230 or 115 V AC; external fuse 16 A gG)
- +G313: Power supply connection for a motor space heater output (230 V AC; external fuse 16 A gG).

Using power factor compensation capacitors with the drive

Power factor compensation is not needed with AC drives. However, if a drive is to be connected in a system with compensation capacitors installed, note the following restrictions.



WARNING!

Do not connect power factor compensation capacitors or harmonic filters to the motor cables (between the drive and the motor). They are not meant to be used with AC drives and can cause permanent damage to the drive or themselves.

If there are power factor compensation capacitors in parallel with the input of the drive:

1. Do not connect a high-power capacitor to the power line while the drive is connected. The connection will cause voltage transients that may trip or even damage the drive.
2. If capacitor load is increased/decreased step by step when the AC drive is connected to the power line, make sure that the connection steps are low enough not to cause voltage transients that would trip the drive.
3. Make sure that the power factor compensation unit is suitable for use in systems with AC drives, ie, harmonic generating loads. In such systems, the compensation unit should typically be equipped with a blocking reactor or harmonic filter.

Using a safety switch between the drive and the motor

ABB recommends to install a safety switch between the permanent magnet motor and the drive output. The switch is needed to isolate the motor from the drive during maintenance work on the drive.

Implementing the control of a contactor between drive and motor

Implementing the control of the output contactor depends on the motor control mode and stopping method selected.

When you select the DTC motor control mode and the motor ramp stop mode, use this operation sequence to open the contactor:

1. Give a stop command to the drive.
2. Wait until the drive decelerates the motor to zero speed.
3. Open the contactor.



WARNING!

If DTC motor control mode is in use, do not open the output contactor while the drive controls the motor. The motor control operates faster than the contactor, and tries to maintain the load current. This can cause damage to the contactor.

When you select the DTC motor control mode and the motor coast stop mode, you can open the contactor immediately after the drive has received the stop command. This is the case also if you use the scalar motor control mode.

Implementing a bypass connection

If bypassing is required, employ mechanically or electrically interlocked contactors between the motor and the drive and between the motor and the power line. Make sure with interlocking that the contactors cannot be closed simultaneously. The installation must be clearly marked as defined in IEC/EN 61800-5-1, subclause 6.5.3, for example, "THIS MACHINE STARTS AUTOMATICALLY".

Bypass connection is available as a factory-installed option for certain cabinet-built drive types. Consult ABB for more information.



WARNING!

Never connect the drive output to the electrical power network. The connection may damage the drive.

Protecting the contacts of relay outputs

Inductive loads (relays, contactors, motors) cause voltage transients when switched off.

The relay contacts on the drive control unit are protected with varistors (250 V) against overvoltage peaks. In spite of this, it is highly recommended that inductive loads are equipped with noise attenuating circuits (varistors, RC filters [AC] or diodes [DC]) in order to minimize the EMC emission at switch-off. If not suppressed, the disturbances may connect capacitively or inductively to other conductors in the control cable and form a risk of malfunction in other parts of the system.

Install the protective component as close to the inductive load as possible. Do not install protective components at the relay outputs.

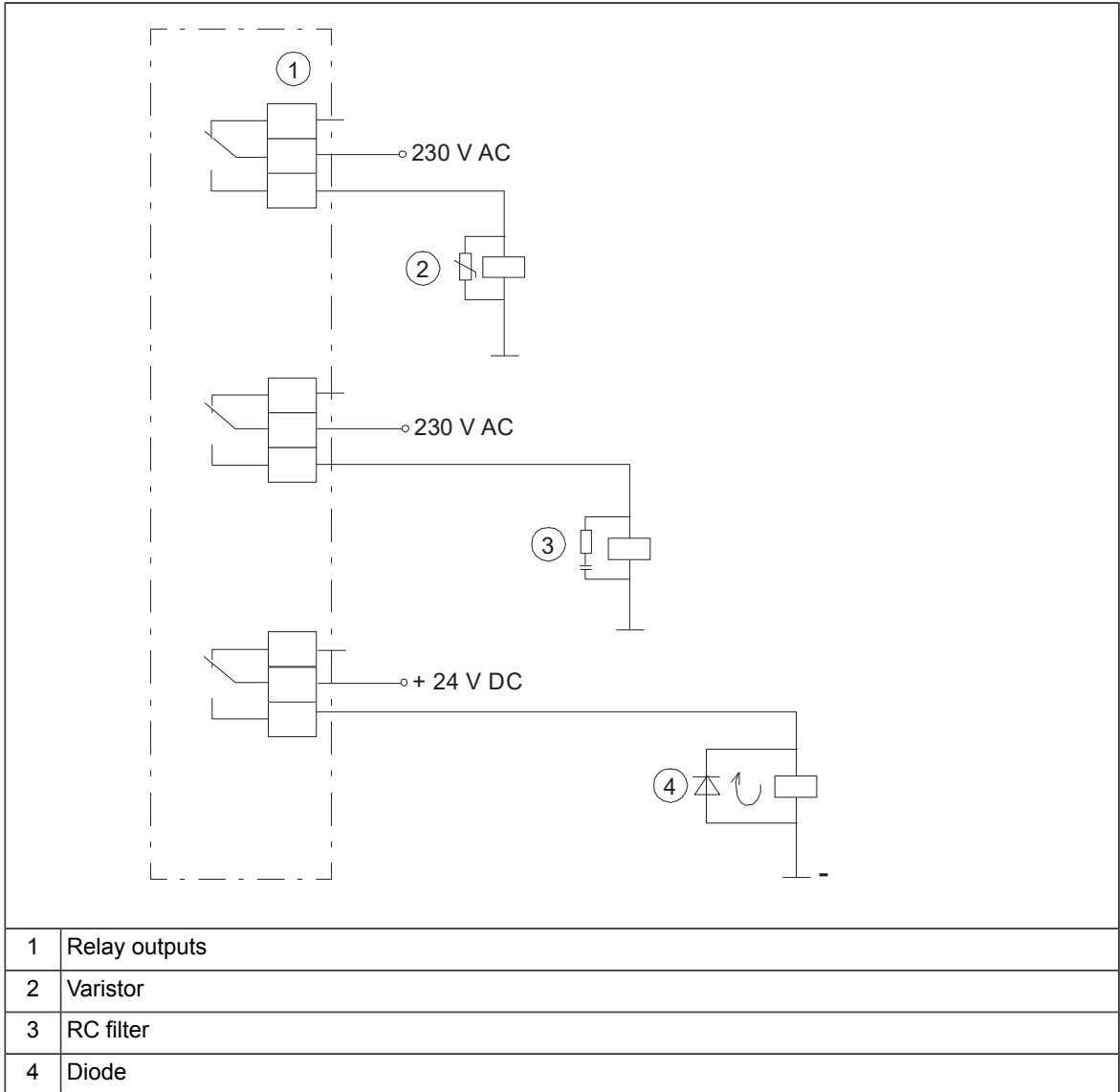

Implementing a motor temperature sensor connection



WARNING!

IEC 61800-5-1 requires double or reinforced insulation between live parts and accessible parts when:

- the accessible parts are not conductive, or
- the accessible parts are conductive, but not connected to the protective earth.

Obey this requirement when you plan the connection of the motor temperature sensor to the drive.

You have these implementation alternatives:

1. If there is double or reinforced insulation between the sensor and the live parts of the motor: You can connect the sensor directly to the analog/digital input(s) of the drive. See the control cable connection instructions.
2. If there is basic insulation between the sensor and the live parts of the motor: You can connect the sensor to the analog/digital input(s) of the drive. All other circuits connected to the digital and analog inputs (typically extra-low voltage circuits) must be:
 - protected against contact, and
 - insulated with basic insulation from other low-voltage circuits. The insulation must be rated for the same voltage level as the drive main circuit.

Note: Extra-low voltage circuits (for example, 24 V DC) typically do not meet these requirements.

As an alternative, you can connect the sensor with basic insulation to the analog/digital input(s) of the drive, if you do not connect any other external control circuits to the drive digital and analog inputs.

3. You can connect the sensor to the drive via an option module. The sensor and the module must form a double or reinforced insulation between the motor live parts and the drive control unit. See [Connecting motor temperature sensor to the drive via an option module \(page 106\)](#).
4. You can connect a sensor to a digital input of the drive via an external relay. The sensor and the relay must form a double or reinforced insulation between the motor live parts and the digital input of the drive.

■ Connecting motor temperature sensor to the drive via an option module

This table shows:

- option module types that you can use for the motor temperature sensor connection
 - insulation or isolation level that each option module forms between its temperature sensor connector and other connectors
 - temperature sensor types that you can connect to each option module
 - temperature sensor insulation requirement in order to form, together with the insulation of the option module, a reinforced insulation between the motor live parts and the drive control unit.
-

Option module		Temperature sensor type			Temperature sensor insulation requirement
Type	Insulation/Isolation	PTC	KTY	Pt100, Pt1000	
FIO-11	Galvanic isolation between sensor connector and other connectors (including drive control unit connector)	-	x	x	Reinforced insulation
FEN-xx	Galvanic isolation between sensor connector and other connectors (including drive control unit connector)	x	x	-	Reinforced insulation
FAIO-01	Basic insulation between sensor connector and drive control unit connector. No insulation between sensor connector and other I/O connectors.	x	x	x	Basic insulation. Connectors of option module other than sensor connector must be left unconnected.
FPTC-xx ¹⁾	Reinforced insulation between sensor connector and other connectors (including drive control unit connector).	x	-	-	No special requirement

¹⁾ Suitable for use in safety functions (SIL2 / PL c rated).



6

Electrical installation

Contents of this chapter

This chapter contains instructions for electrical installation of the drive.

Safety



WARNING!

If you are not a qualified electrical professional, do not do installation or maintenance work. Obey the safety instructions of the drive. If you ignore them, injury or death, or damage to the equipment can occur.

Measuring the insulation

- **Measuring the insulation of the drive**



WARNING!

Do not do any voltage withstand or insulation resistance tests on any part of the drive as testing can damage the drive. Every drive has been tested for insulation between the main circuit and the chassis at the factory. Also, there are voltage-limiting circuits inside the drive which cut down the testing voltage automatically.

- **Measuring the insulation of the input power cable**

Before you connect the input power cable to the drive, measure its insulation according to local regulations.



■ Measuring the insulation of the motor and motor cable



WARNING!

Obey the safety instructions of the drive. If you ignore them, injury or death, or damage to the equipment can occur. If you are not a qualified electrical professional, do not do installation or maintenance work.

1. Do the steps in section *Electrical safety precautions (page 18)* before you start the work.
2. Make sure that the motor cable is disconnected from the drive output terminals.
3. Measure the insulation resistance between each phase conductor and the protective earth conductor. Use a measuring voltage of 1000 V DC. The insulation resistance of an ABB motor must be more than 100 Mohm (reference value at 25 C [77°F]). For the insulation resistance of other motors, refer to the manufacturer's instructions.

Note: Moisture inside the motor casing reduces the insulation resistance. If you think that there is moisture in the motor, dry the motor and do the measurement again.

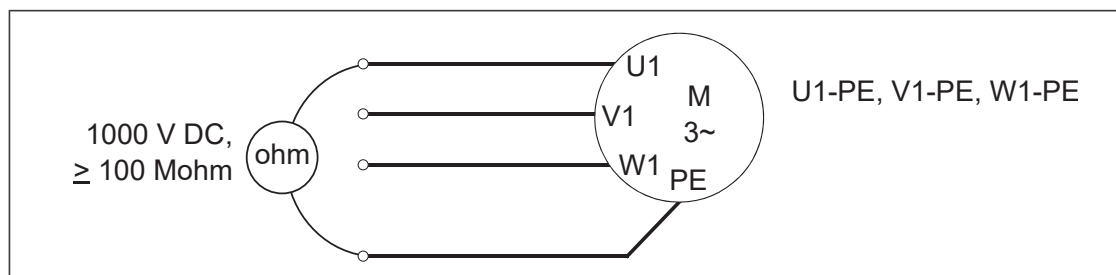

■ Custom brake resistor assembly

Check the insulation of the brake resistor assembly (if present) as follows:



WARNING!

Obey the safety instructions of the drive. If you ignore them, injury or death, or damage to the equipment can occur.

1. Stop the drive and do the steps in section *Electrical safety precautions (page 18)* before you start the work.
2. Check that the resistor cable is connected to the resistor, and disconnected from the drive output terminals R+ and R-.
3. At the drive end, connect the R+ and R- conductors of the resistor cable together. Measure the insulation resistance between the combined conductors and the PE conductor by using a measuring voltage of 1 kV DC. The insulation resistance must be higher than 1 Mohm.

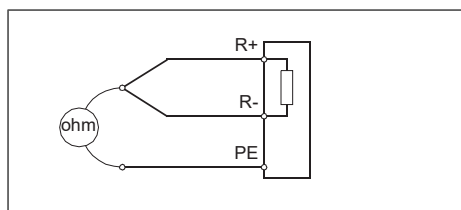

Grounding system compatibility check

The standard drive with no EMC filter and the ground-to-phase varistor connected can be installed to a symmetrically grounded TN-S system. If you install the drive to another system, you may need to disconnect the EMC filter and ground-to-phase varistor. See *ACS880 frames R1 to R11 EMC filter and ground-to-phase varistor disconnecting instructions* ([3AUA0000125152](#) [English]).

**WARNING!**

Do not install the drive with EMC filter options +E200 and +E202 to a system that the filter is not suitable for. This can cause danger, or damage the drive.



WARNING! Do not install the drive with ground-to-phase varistor connected to a system that the varistor is not suitable for. If you do, the varistor circuit can be damaged.

■ Corner-grounded and midpoint-grounded 525...690 V delta systems

**WARNING!**

Do not install the drive on a 525...690 V corner-grounded or midpoint-grounded delta system. Disconnecting the EMC filter and ground-to-phase varistor does not prevent damage to the drive



Connecting the power cables

■ Connection diagram

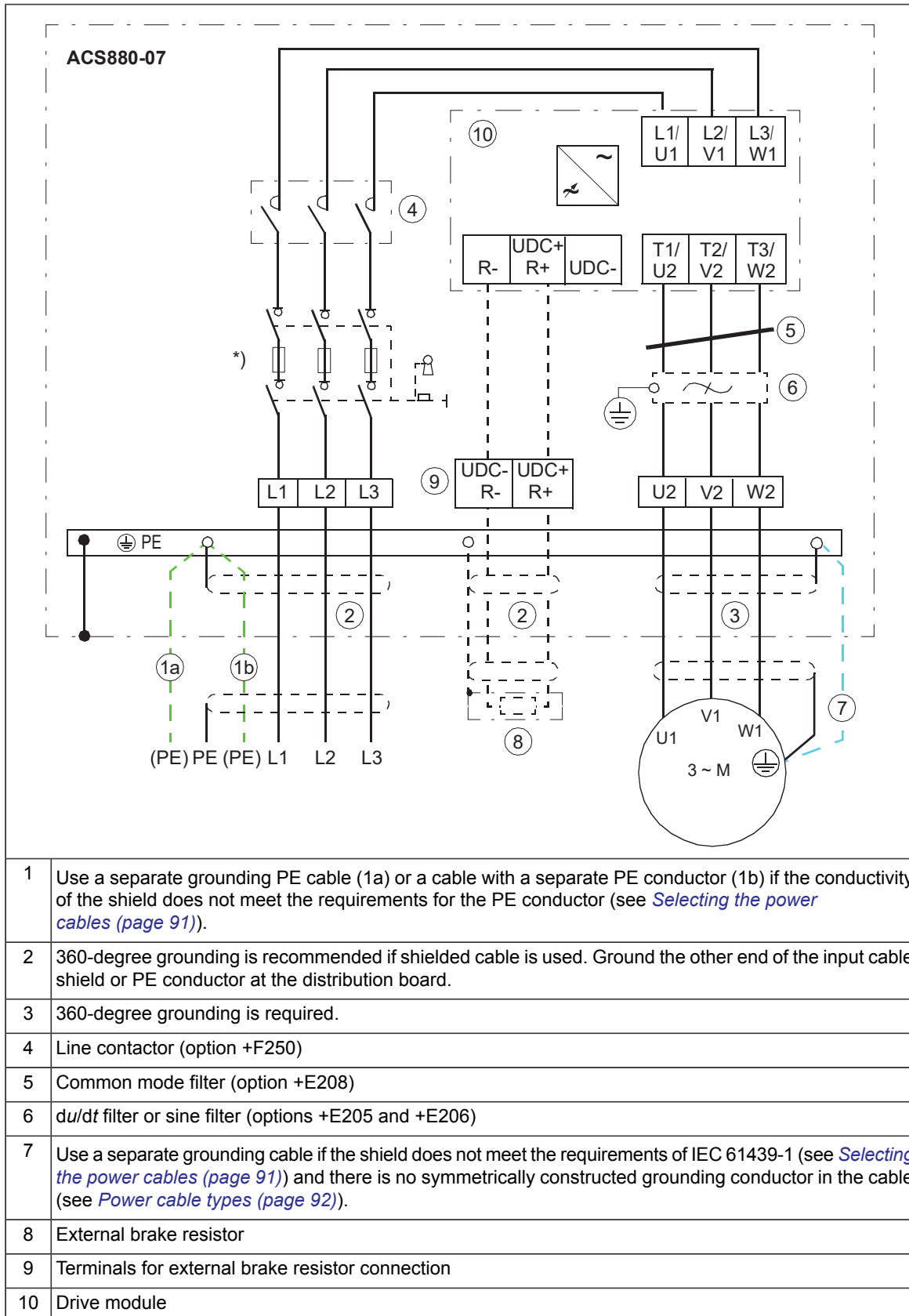

Note: If there is a symmetrically constructed grounding conductor on the motor cable in addition to the conductive shield, connect the grounding conductor to the grounding terminal at the drive and motor ends.
 Do not use an asymmetrically constructed motor cable. Connecting its fourth conductor at the motor end increases bearing currents and causes extra wear.
 *) Switch-disconnector and separate fuses in frames R9...R11.

■ **Layout of the power cable connection terminals and entries (frames R6 to R8)**

The layout of power cable connection terminals and cable entries of the standard drive is shown below.

Note: You have to remove the “door” fan to get access to the cable terminals and entries (see *Replacing the cabinet “door” fans (page 166)*).

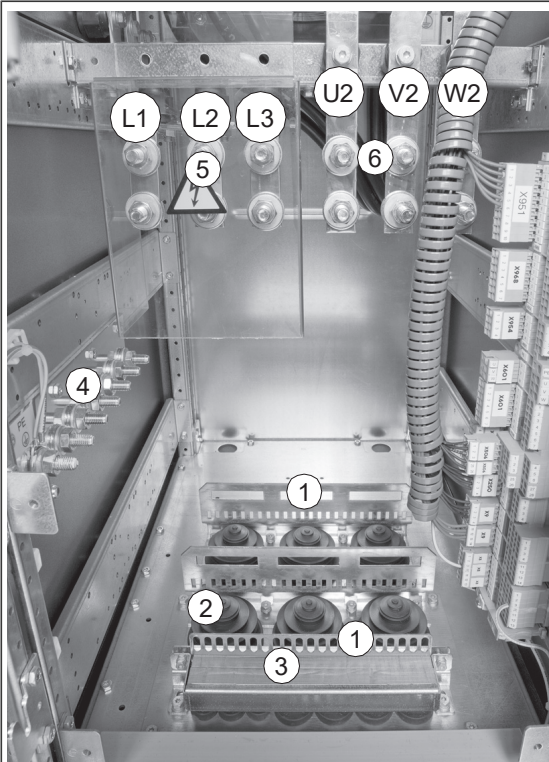

1	Strain relief
2	Power cable entries. Conductive sleeve under the grommet. The grommets are included in IP54 units only.
3	Control cable entry with EMI conductive cushions.
4	PE terminal
5	Input power cable terminals L1, L2 and L3
6	Motor cable terminals U2, V2, W2



■ Layout of the power cable connection terminals and entries (frames R6 to R8 with option +C129)

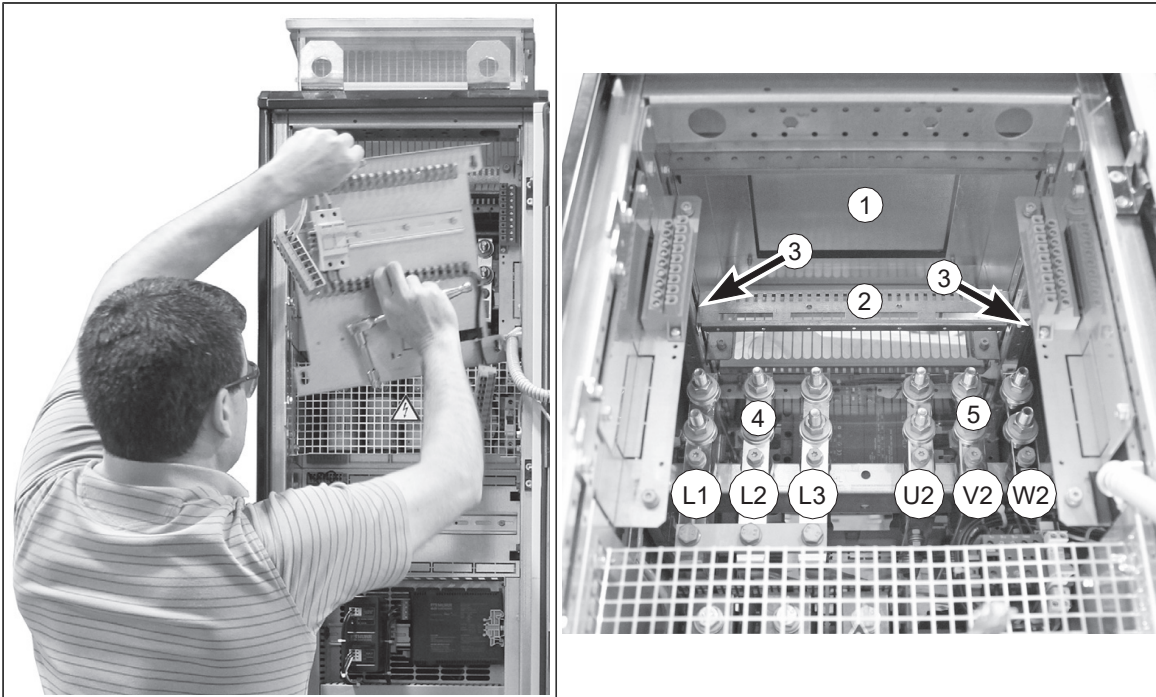

1	Power cable entries
2	Strain relief
3	Ground bar
4	Input cable power connection terminals L1, L2 and L3
5	Motor cable connection terminals U2, V2, W2



■ **Layout of the power cable connection terminals and entries (frames R6 to R8 with options +C129+F277+F289)**

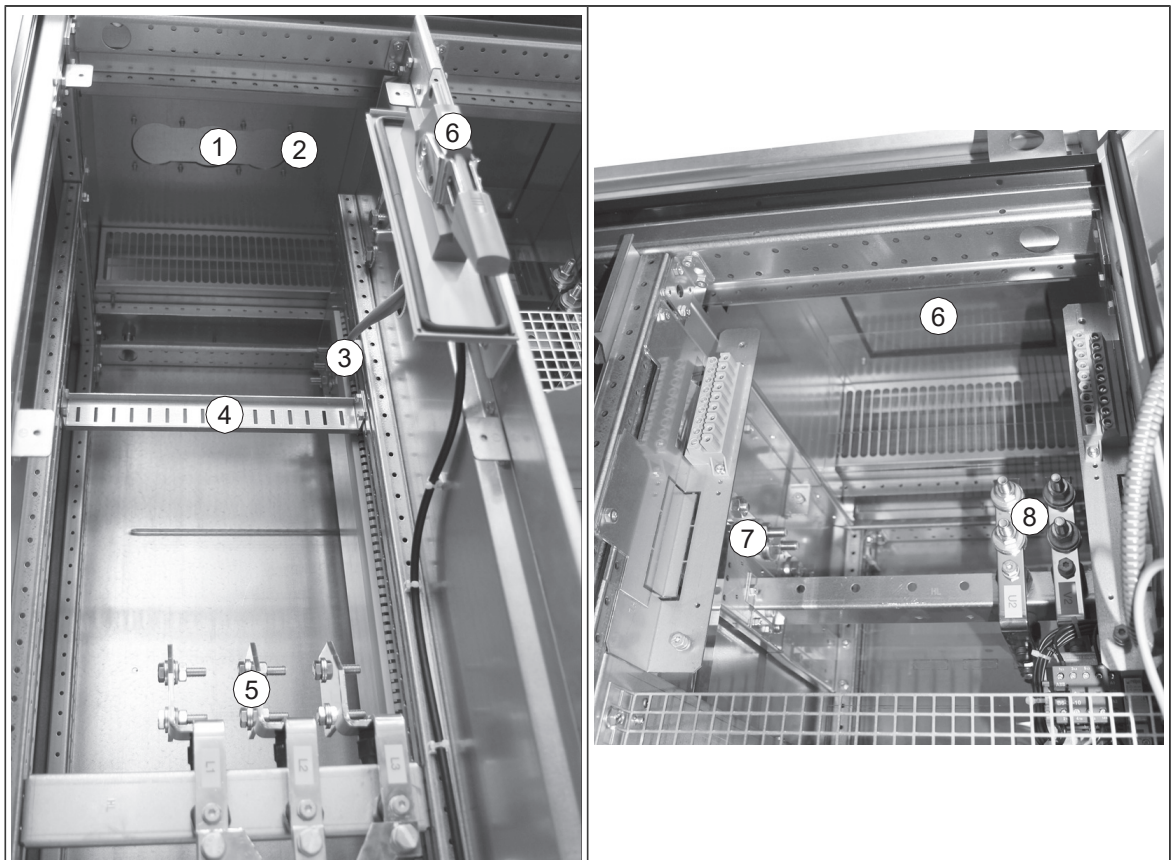

1	Input power cable entry	6	Motor cable entry
2	Control cable entry	7	Ground bar for motor cables
3	Ground bar for input power cables	8	Motor cable connection terminals U2, V2, W2
4	Strain relief		
5	Input cable power connection terminals L1, L2		
6	Flange mounted switch for molded case circuit breaker (+F277)		



■ **Layout of the input and motor cable connection terminals (frame R9 with option +E205)**

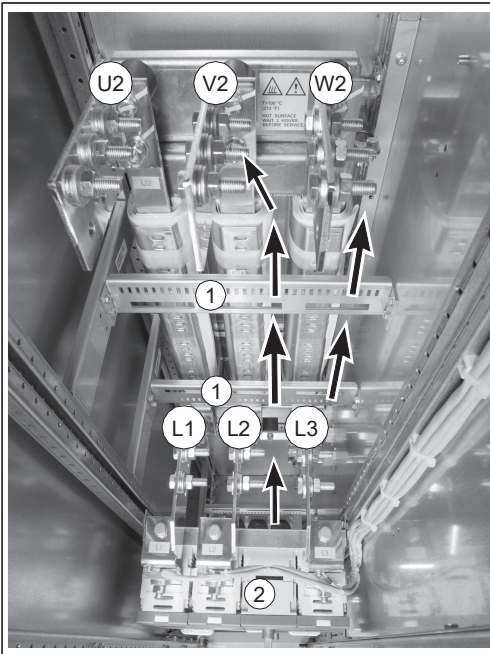

1	Strain relief
L1, L2, L3	Input power cable terminals
U2, V2, W2	Motor cable terminals
2	Main switch-disconnector
Cable routing from below is shown with the arrows.	



■ **Layout of the power cable connection terminals and entries (frame R9 with option +C129)**

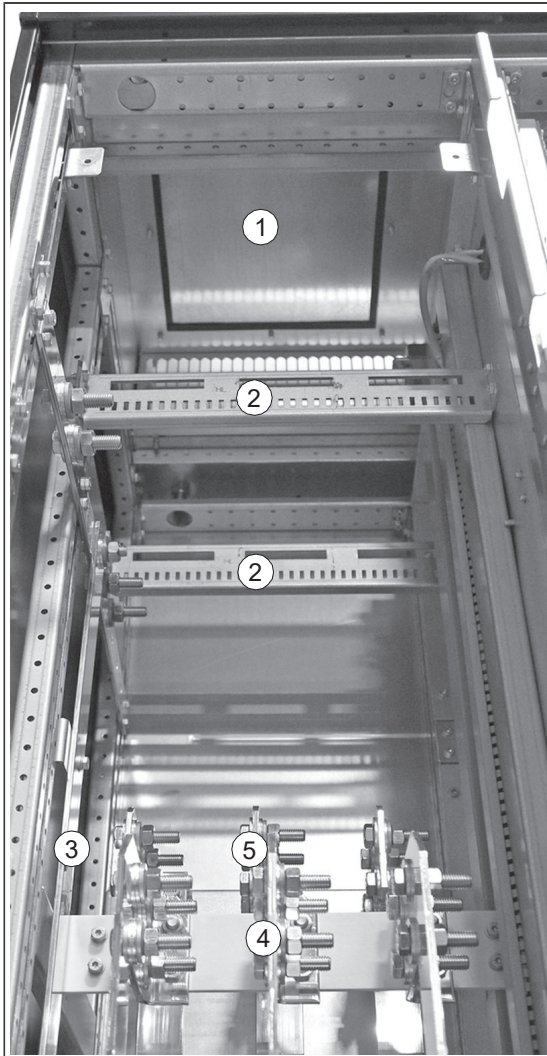

1	Power cable entry
2	Strain relief
3	Ground bar
4	Input cable power connection terminals L1, L2 and L3
5	Motor cable connection terminals U2, V2, W2



■ **Layout of the input and motor cable connection terminals (frames R10 and R11)**

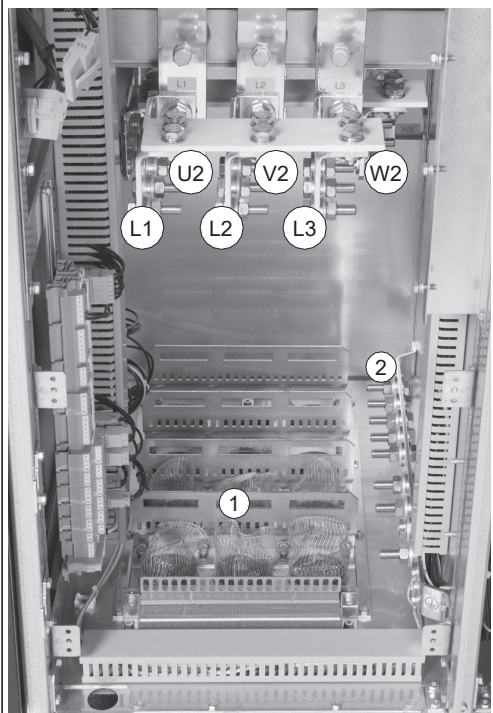

1	Strain relief
L1, L2, L3	Input power cable terminals
U2, V2, W2	Motor cable terminals
2	PE terminal

■ **Layout of the input and motor cable connection terminals (frames R10 and R11 with option +C129)**

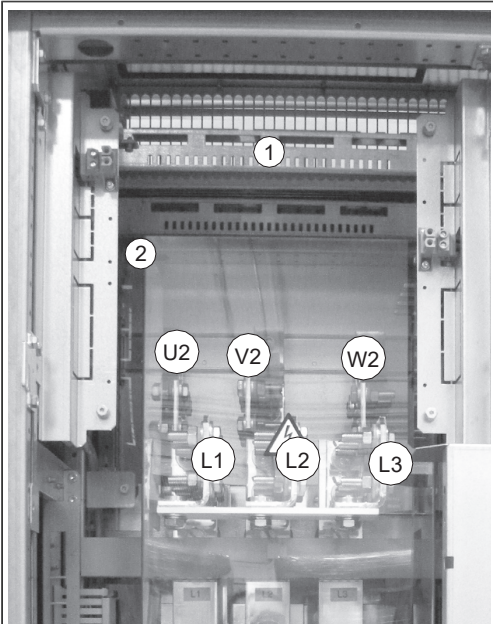

1	Strain relief
L1, L2, L3	Input power cable terminals
U2, V2, W2	Motor cable terminals
2	PE terminal

■ **Entry of external resistor and DC cables**

Run the external brake resistor cables and DC cables into the drive cabinet through the power cable entries at the base of the drive module cubicle. In frames R6 to R8 the connection terminals are in the drive module. In frame R9, the connection terminals are located below the drive module.

■ **Connection procedure (IEC)**

1. Do the steps in section *Electrical safety precautions (page 18)* before you start the work.
2. Open the cabinet door.
3. Open the swing-out frame.
4. For frames R6 to R11: Remove the mounting plate(s) above the cabinet “door” fan by undoing the mounting screws. With options +G300, +G307, +G313: Unplug the connectors at the back of the mounting plate.
5. Remove the fan mounting plate by loosening the mounting screws and lifting it up. Unplug the fan supply cables.
6. For frames R9 to R11: Remove the shrouds on the power cable terminals.
7. Peel off 3 to 5 cm of the outer insulation of the cables above the entry plate for the 360° high-frequency grounding.

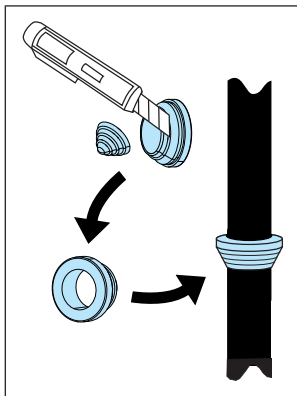

8. Prepare the ends of the cables.



WARNING!

Apply grease to stripped aluminum conductors before attaching them to non-coated aluminum cable lugs. Obey the grease manufacturer’s instructions. Aluminum-aluminum contact can cause oxidation in the contact surfaces.

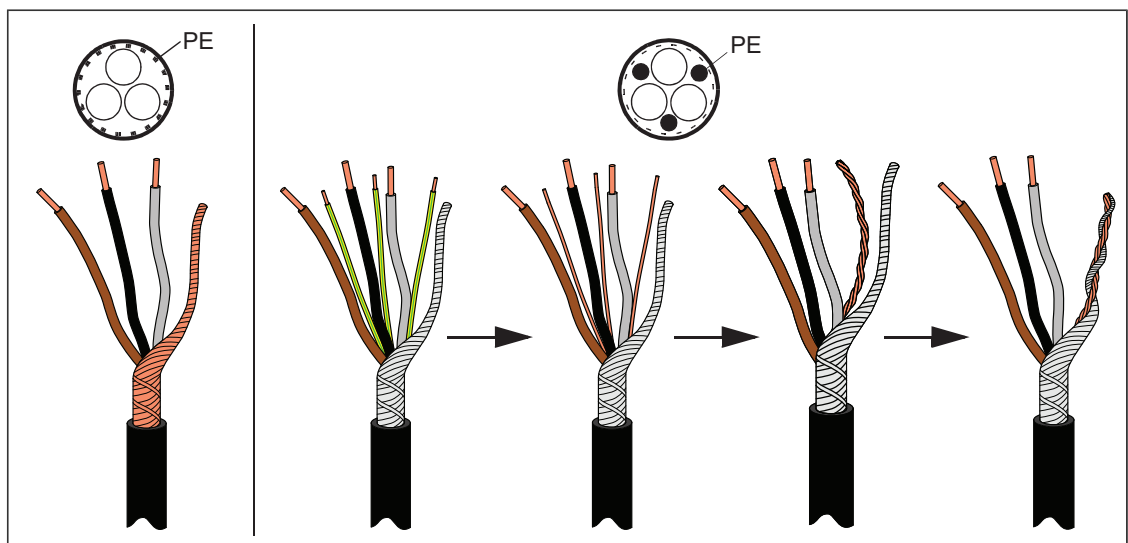

9. If fire insulation is used, make an opening in the mineral wool sheet according to the diameter of the cable.
10. Slide the cables through the entries with the conductive sleeves. Remove rubber grommets from the entry plate for the cables to be connected. Cut adequate holes into the rubber grommets. Slide the grommets onto the cables. Slide the cables through the entries with the conductive sleeves and attach the grommets to the holes. Fasten the conductive sleeves to the cable shields with cable ties.

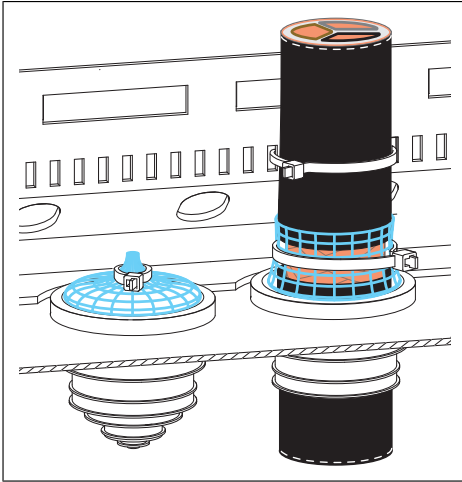

11. Seal the slot between the cable and mineral wool sheet (if used) with sealing compound (eg, CSD-F, ABB brand name DXXT-11, code 35080082).
12. Tie up the unused conductive sleeves with cable ties.
13. Connect the twisted shields of the motor cables to the ground bar and the phase conductors to the U2, V2 and W2 terminals.
14. For drives with external brake resistors (option +D150 and no +D151): Connect the twisted shields of the resistor cables (if present) to the ground bar and the conductors to the R- and R+ terminals.
15. Connect the twisted shields of the input cables and separate ground cable (if present) to the PE terminal of the cabinet and the phase conductors to the L1, L2 and L3 terminals.
16. Tighten the power cable screws to the torque given in *Terminal and entry data for the power cables on page 210*.
17. Reinstall the shroud(s) and mounting plates.

■ Connection procedure (US)



WARNING!

Apply grease to stripped aluminum conductors before attaching them to non-coated aluminum cable lugs. Obey the grease manufacturer's instructions. Aluminum-aluminum contact can cause oxidation in the contact surfaces.

1. Do the steps in section *Electrical safety precautions (page 18)* before you start the work.
2. Open the cabinet door.
3. Open the swing-out frame (if installed).
4. Plan cable access and mark the conduit plate accordingly for the input and output power and control cables.

5. Remove the conduit plate from the drive cabinet and cut holes as needed for the conduit connections.
Note: Never cut metal in or around an equipment cabinet. Metal debris can cause damage to electrical equipment and hazardous conditions.
6. Reinstall the conduit plate to cabinet and connect all electrical conduits as needed to conduit plate. Do not leave any open holes at the top of the cabinet.
7. Run the motor power cables and separate ground cable (if present) from the motor to cabinet.
8. Connect the motor power cable shields and separate ground cable (if present) to the ground bar at the top of the cabinet.
9. Connect the motor phase conductors to the output power terminals U2, V2 and W2.
10. For drives with external brake resistors (option +D150 and no +D151):
 - Run the power cables from the brake resistor to the cabinet including the proper grounding cable.
 - Connect the ground cable to the ground bar at top of cabinet.
 - Connect the brake resistor power cables to the R- and R+ terminals.
11. Make sure that all power is disconnected and reconnection is not possible. Use proper safe disconnect procedures according to local codes.
12. Run the AC power supply cables and separate ground cables (if present) from the supply source to the cabinet.
13. Connect AC power supply cable shields and separate ground cables (if present) to the ground bar at top of cabinet.
14. Connect AC supply phase conductors to terminals L1, L2 and L3.
15. Reinstall the shroud(s) and mounting plates.

■ **Grounding the motor cable shield at the motor end**

For minimum radio-frequency interference, ground the cable shield 360 degrees at the cable entry of the motor terminal box.

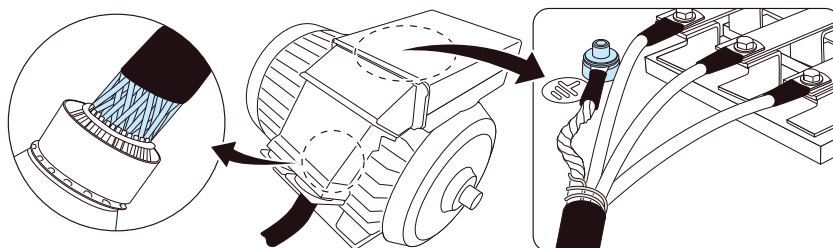

■ **DC connection (option +H356)**

The UDC+ and UDC- terminals are intended for common DC configurations of a number of drives, allowing regenerative energy from one drive to be utilized by the other drives in motoring mode. Contact your local ABB representative for further instructions.

Connecting the control cables

See chapter [Control units of the drive \(page 141\)](#) for the default I/O connections of the drive (with ACS880 primary control program). The default I/O connections can be different with

some hardware options, see the circuit diagrams delivered with the drive for the actual wiring. For other control programs, see their firmware manuals.

Connect the cables as described under [Control cable connection procedure \(page 122\)](#)

■ Control cable connection procedure



WARNING!

Obey the safety instructions of the drive. If you ignore them, injury or death, or damage to the equipment can occur.

1. Stop the drive (if running) and do the steps in section [Electrical safety precautions \(page 18\)](#) before you start the work.
2. **Frames R6 to R9:** Remove the cabinet fan and mounting plate above it as described in section [Connecting the power cables \(page 112\)](#)
3. Run the control cables into the drive module cubicle as described in section [Grounding the outer shields of the control cables at the cabinet entries](#) below.
4. Route the control cables as described in section [Routing the control cables inside the cabinet \(frames R6 to R8\) \(page 124\)](#) or [Routing the control cables inside the cabinet \(frame R9\) \(page 125\)](#) or [Routing the control cables inside the cabinet \(frames R10 and R11\) \(page 126\)](#)
5. Connect the control cables as described in sections [Connecting the control unit cables \(page 126\)](#) ... [Wiring ground fault monitoring for IT ungrounded systems \(option +Q954\) \(page 132\)](#)

Grounding the outer shields of the control cables at the cabinet entry

Ground the outer shields of all control cables 360 degrees at the EMI conductive cushions as follows (example constructions are shown below, the actual hardware may vary):

1. Loosen the tightening screws of the EMI conductive cushions and pull the cushions apart.
2. Cut adequate holes to the rubber grommets in the entry plate and put the cables through the grommets and the cushions.
3. Strip off the cable plastic sheath above the entry plate just enough to ensure proper connection of the bare shield and the EMI conductive cushions.
4. Tighten the two tightening screws so that the EMI conductive cushions press tightly round the bare shield.

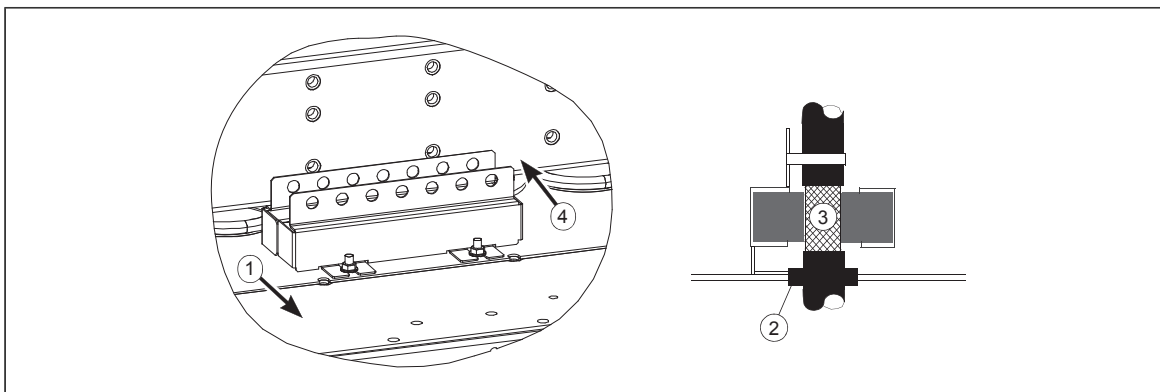

Note 1: Keep the shields continuous as close to the connection terminals as possible. Secure the cables mechanically at the entry strain relief.

Note 2: If the outer surface of the shield is non-conductive:

- Cut the shield at the midpoint of the bare part. Be careful not to cut the conductors or the grounding wire (if present).
- Turn the shield inside out to expose its conductive surface.
- Cover the turned shield and the stripped cable with copper foil to keep the shielding continuous.

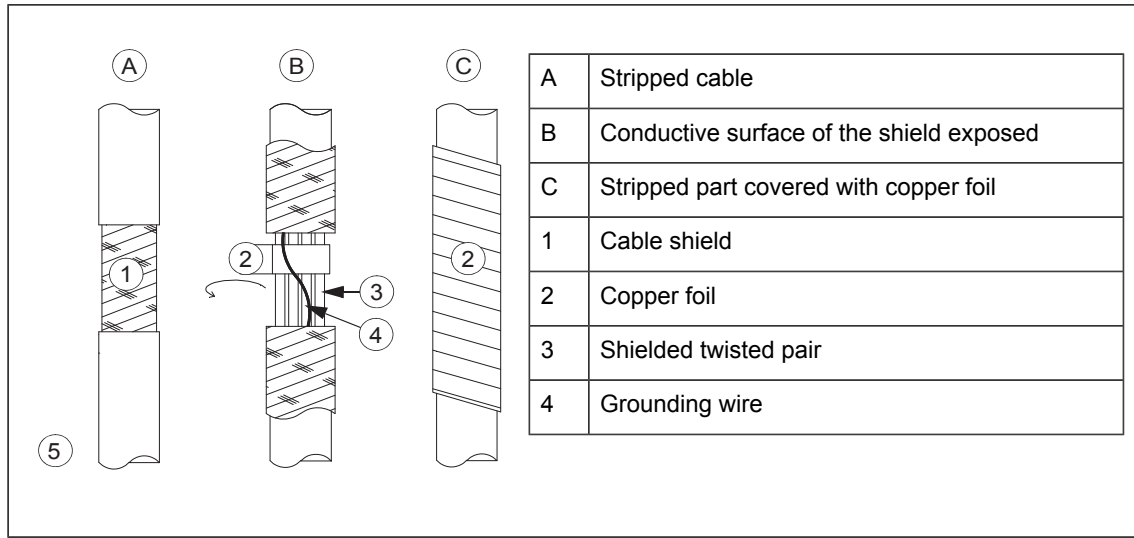

Note for top entry of cables: When each cable has its own rubber grommet, sufficient IP and EMC protection can be achieved. However, if there is more than one cable per grommet, plan the installation beforehand as follows:

1. Make a list of the cables coming to the cabinet.
2. Sort the cables going to the left into one group and the cables going to the right into another group to avoid unnecessary crossing of cables inside the cabinet.
3. Sort the cables in each group according to size.
4. Group the cables for each grommet as follows ensuring that each cable has a proper contact to the cushions on both sides.

Cable diameter in mm	Max. number of cables per grommet
≤ 13	4
≤ 17	3
< 25	2
≥ 25	1



5. Arrange the bunches according to size from thickest to the thinnest between the EMI conductive cushions.

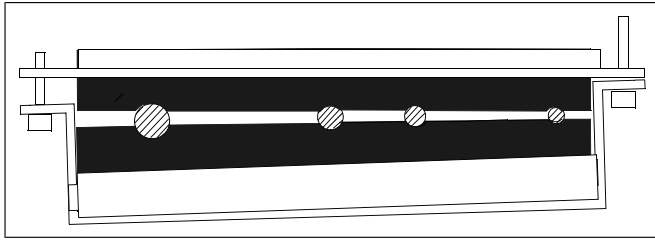

6. If more than one cable go through a grommet, seal the grommet by applying Loctite 5221 (or equivalent adhesive sealant) inside the grommet.

Routing the control cables inside the cabinet (frames R6 to R8)



Routing the control cables inside the cabinet (frame R9)



Routing the control cables inside the cabinet (frames R10 and R11)

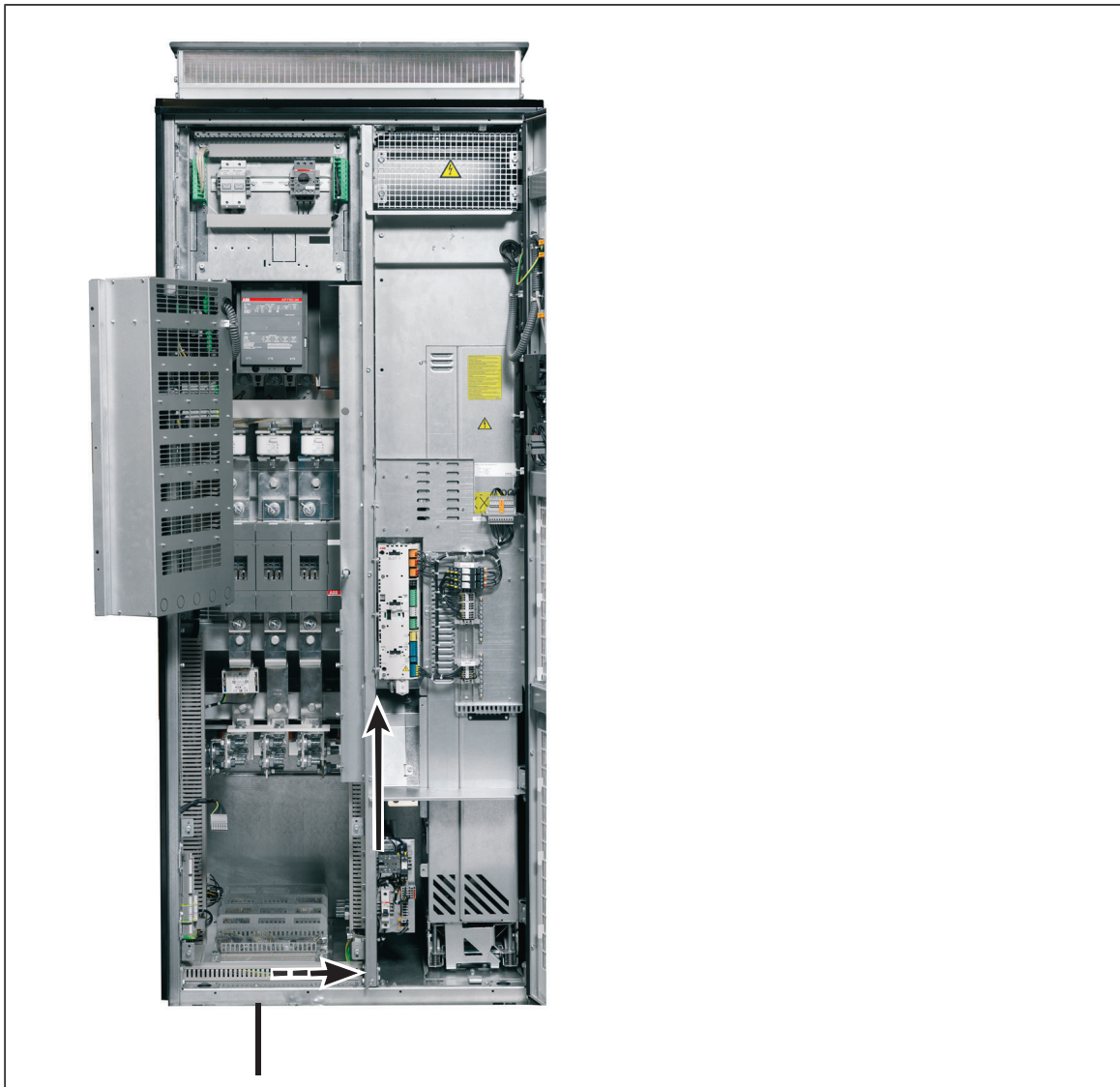

Use the existing trunking in the cabinet wherever possible. Use sleeving if cables are laid against sharp edges. When running cables to or from the swing-out frame, leave enough slack at the hinge to allow the frame to open fully.

Note: Leave some slack in the control wiring to allow the removing of the control unit assembly plate when the drive module is replaced.

Connecting the control unit cables

Note: Keep any signal wire pairs twisted as close to the terminals as possible. Twisting the wire with its return wire reduces disturbances caused by inductive coupling.

Note: For frames R10 and R11: Leave slack to the control wires to make it possible to lift the control unit mounting plate a little when the drive module is replaced.

Units without additional I/O terminal block (option +L504): Ground the pair-cable shields and all grounding wires to the clamp below the control unit as shown below.

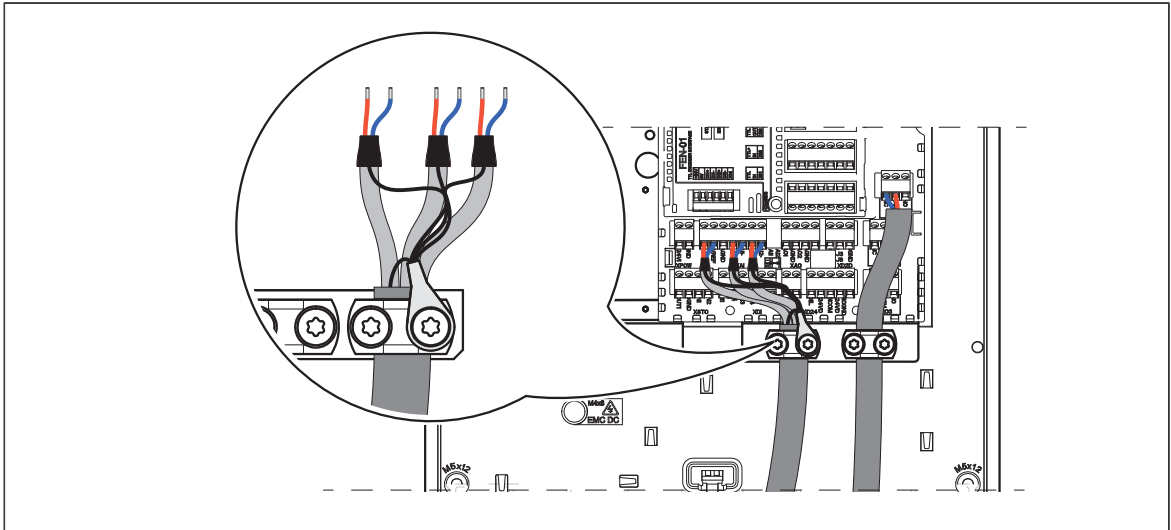

Units with additional I/O terminal block (option +L504): Ground the pair-cable shields and all grounding wires to the grounding clamp below the terminal block as shown below.

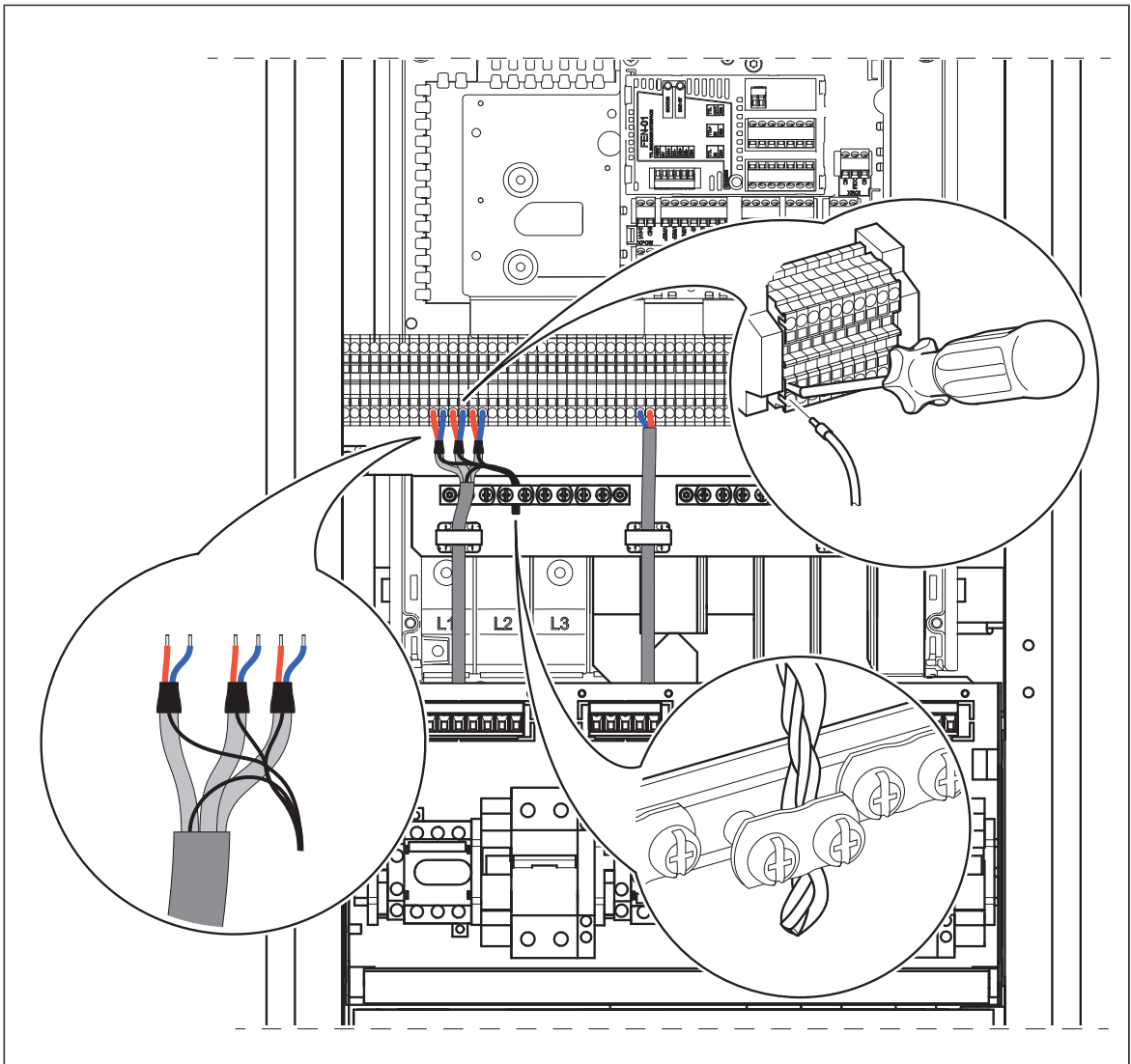

At the other end of the cable, leave the shields unconnected or ground them indirectly via a high-frequency capacitor with a few nanofarads, eg, 3.3 nF / 630 V. The shield can also

be grounded directly at both ends if they are in the same ground line with no significant voltage drop between the end points.

Connect the conductors to the appropriate terminals of the control unit or optional terminal block X504.

Connecting a 230/115 V AC auxiliary voltage supply (UPS, option +G307)

Wire the external control voltage to terminal block X307 as shown below.

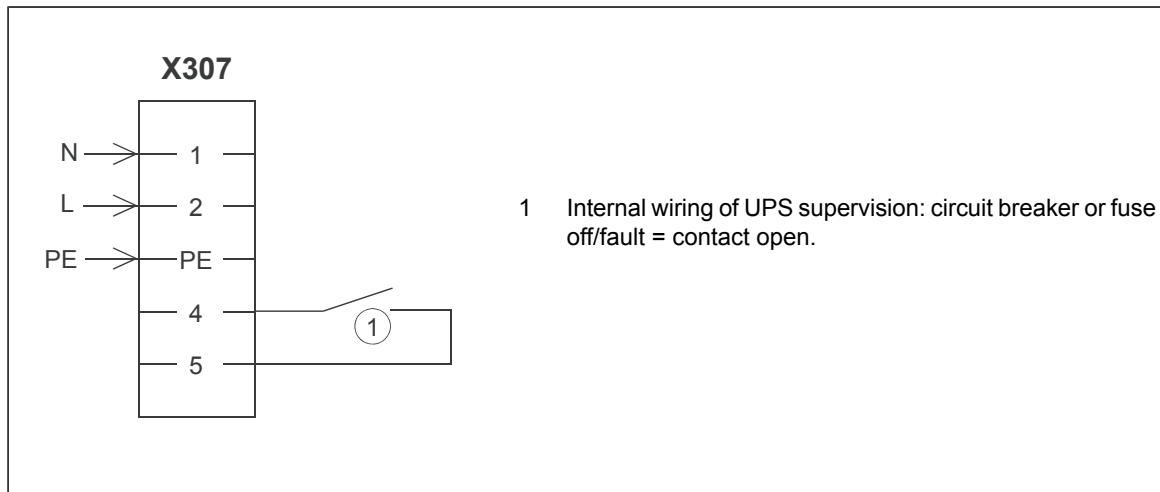

Connecting the emergency stop push buttons (options +Q951, +Q952, +Q963, +Q964, +Q978, +Q979)

Connect external emergency stop push buttons according to the circuit diagrams delivered with the drive.

Wiring the starter for auxiliary motor fan (options +M6xx)

Connect the power supply wires for the auxiliary motor fan to terminal blocks X601...X605 according to the circuit diagrams delivered with the drive.

Wiring the PTC thermistor relay(s) (options +L505, +2L505, +L513 and +2L513)

The external wiring of option +2L505 and +2L513 (two thermistor relays) is shown below. For example, one relay can be used to monitor the motor windings, the other to monitor the bearings. The maximum contact load capacity is 250 V AC 10 A. For the actual wiring, see the circuit diagram delivered with the drive. For instructions on commissioning options +L513 and +2L513, see *ATEX-certified motor thermal protection functions for cabinet-built ACS880 drives (options +L513+Q971 and +L514+Q971) user's manual (3AXD50000014979 [English])*.

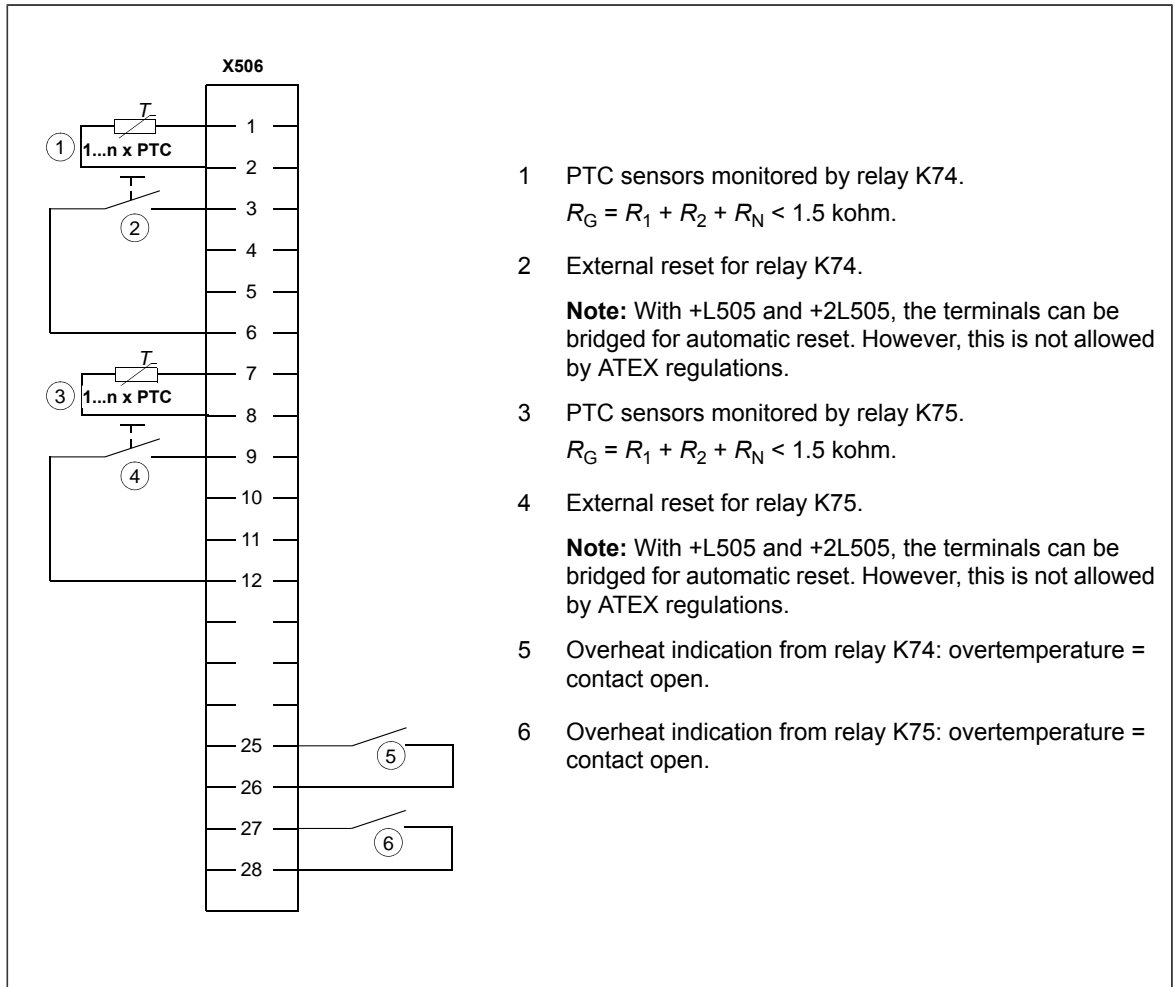

- 1 PTC sensors monitored by relay K74.
 $R_G = R_1 + R_2 + R_N < 1.5 \text{ kohm.}$
- 2 External reset for relay K74.
Note: With +L505 and +2L505, the terminals can be bridged for automatic reset. However, this is not allowed by ATEX regulations.
- 3 PTC sensors monitored by relay K75.
 $R_G = R_1 + R_2 + R_N < 1.5 \text{ kohm.}$
- 4 External reset for relay K75.
Note: With +L505 and +2L505, the terminals can be bridged for automatic reset. However, this is not allowed by ATEX regulations.
- 5 Overheat indication from relay K74: overtemperature = contact open.
- 6 Overheat indication from relay K75: overtemperature = contact open.

Wiring the Pt100 relays (option +nL506)

External wiring of eight Pt100 sensor modules is shown below. Contact load capacity 250 V AC 10 A. For the actual wiring, see the circuit diagram delivered with the drive.



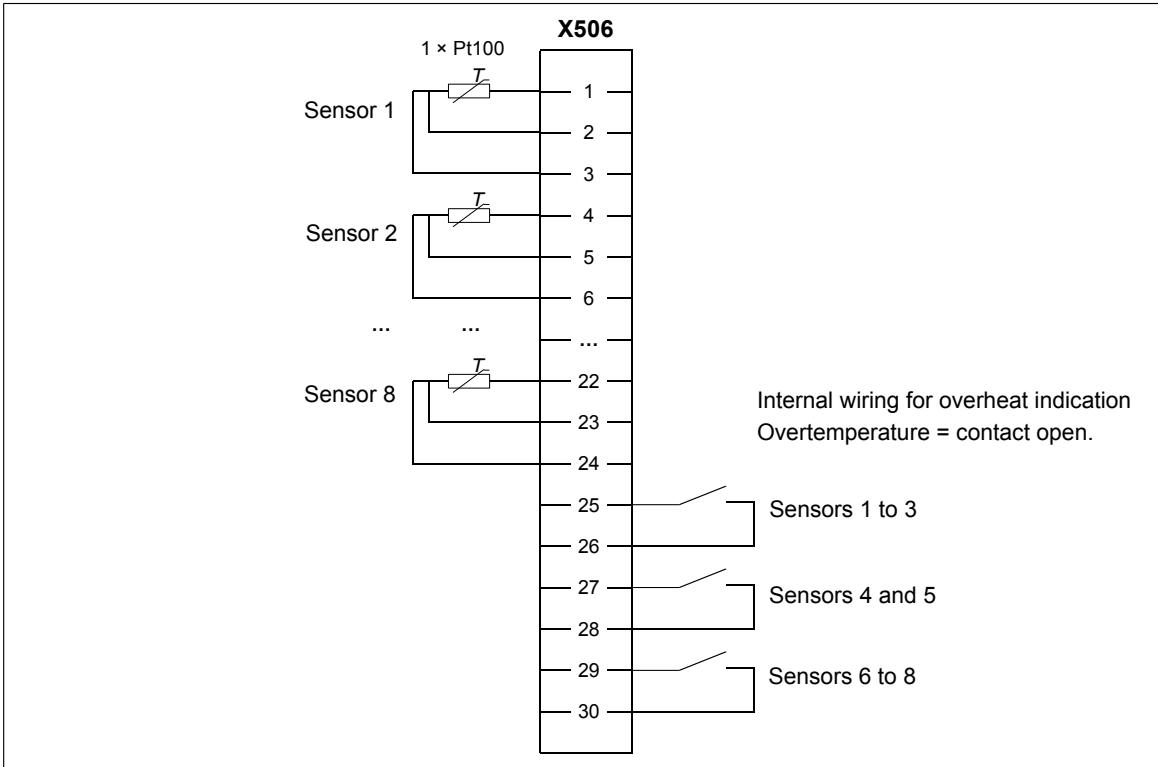

Wiring the Pt100 relays (option +nL514)

External wiring of three Pt100 sensor modules is shown below. Contact load capacity 250 V AC 10 A. For the actual wiring, see the circuit diagram delivered with the drive. For instructions on commissioning option +nL514, see *ATEX-certified motor thermal protection functions for cabinet-built ACS880 drives (options +L513+Q971 and +L514+Q971) user's manual* (3AXD50000014979 [English]).

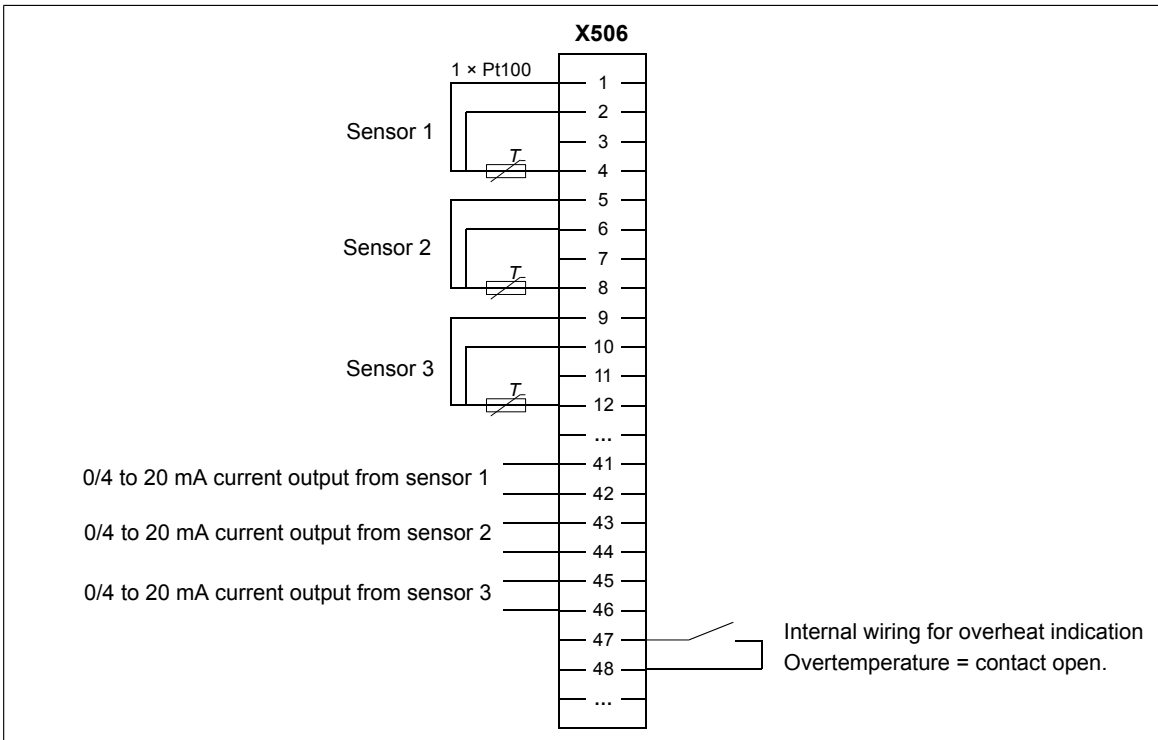

Powering the heating and lighting equipment (options +G300, +G301 and +G313)

See the circuit diagrams delivered with drive.

Connect the external power supply wires for the cabinet heater and lighting to terminal block X300 at the back of the mounting plate.

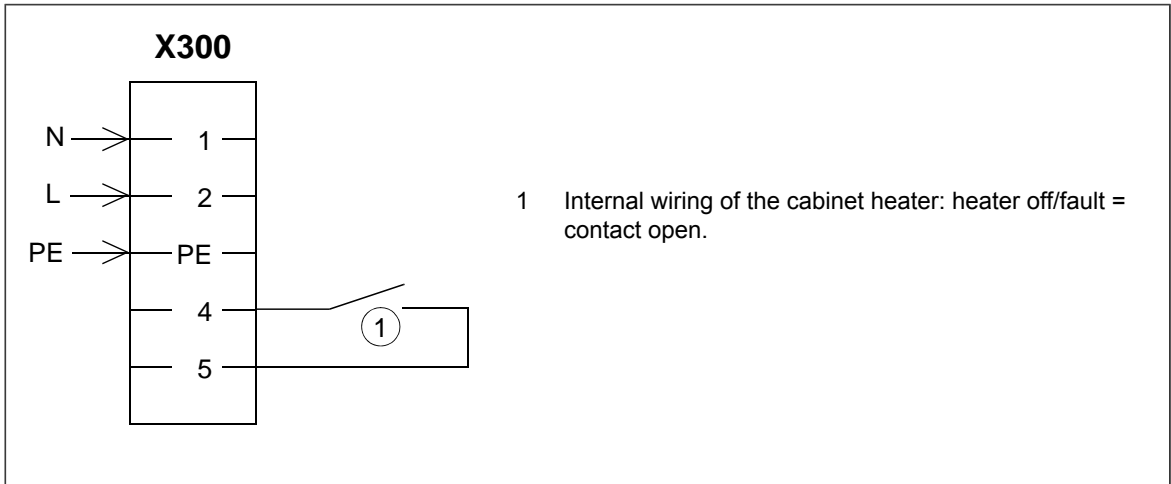

Connect the motor heater wiring to terminal block X313 as shown below. Maximum external power supply 16 A.

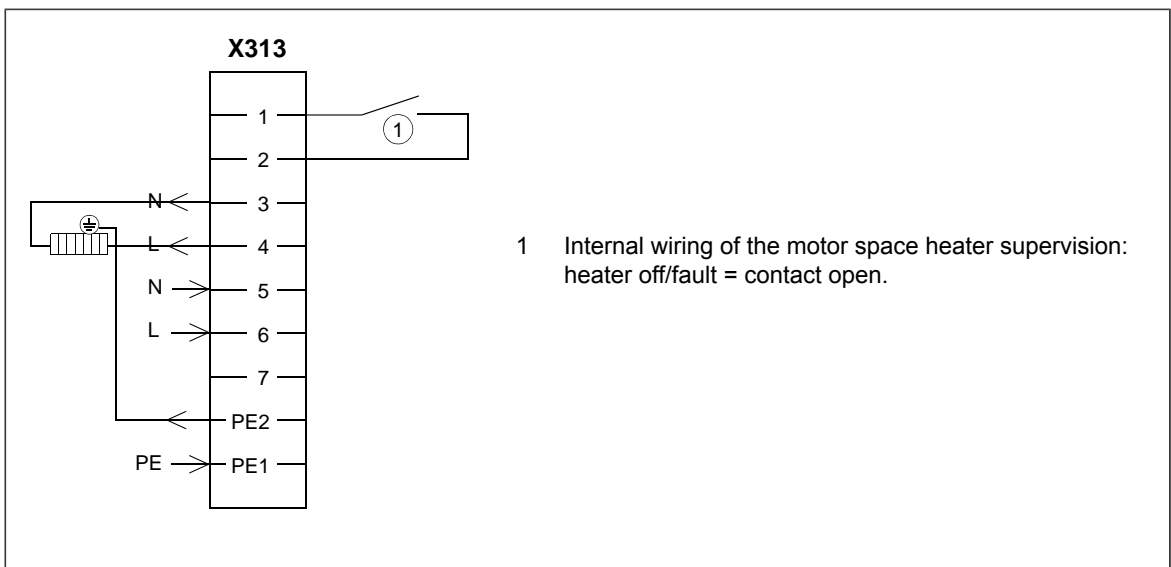

Wiring ground fault monitoring for IT ungrounded systems (option +Q954)

We recommend to connect Alarm 1 for drive tripping and Alarm 2 for alarm signals in order to avoid unnecessary trippings due to the ground fault monitor self testing with Alarm 2.

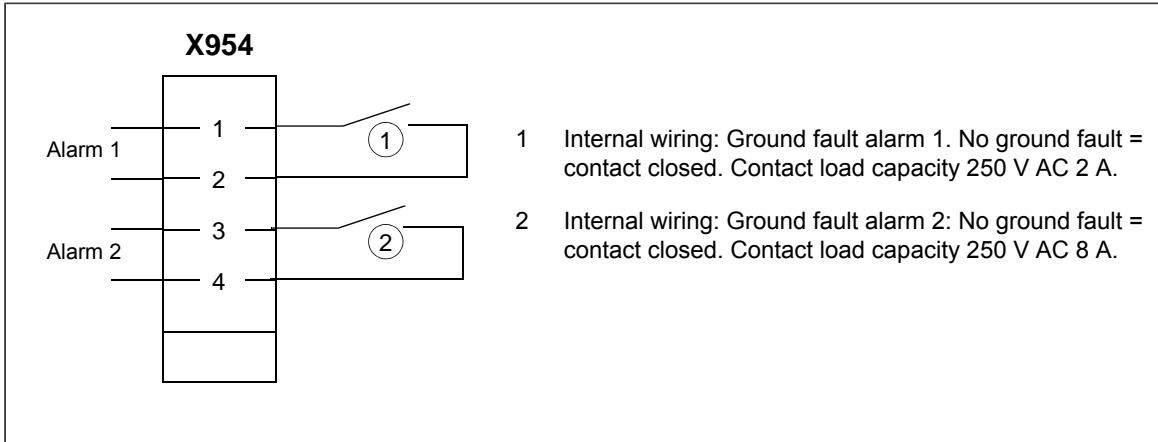

Setting the voltage range of the auxiliary control voltage transformer (T21)

Connect the power supply wires of the auxiliary control voltage transformer according to the power network voltage.

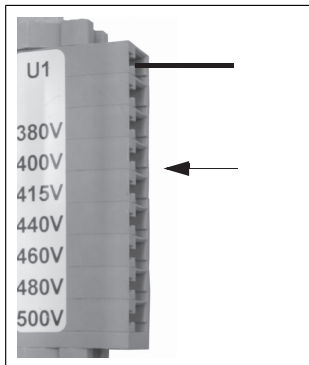

Connecting a PC



WARNING!

Do not connect the PC directly to the control panel connector of the control unit as this can cause damage.

A PC (with eg, the Drive composer PC tool) can be connected as follows:

1. Connect an ACx-AP-x control panel to the unit either
 - by inserting the control panel into the panel holder or platform, or
 - by using an Ethernet (eg, Cat 5e) networking cable.
2. Remove the USB connector cover on the front of the control panel.
3. Connect an USB cable (Type A to Type Mini-B) between the USB connector on the control panel (3a) and a free USB port on the PC (3b).
4. The panel will display an indication whenever the connection is active.
5. See the documentation of the PC tool for setup instructions.

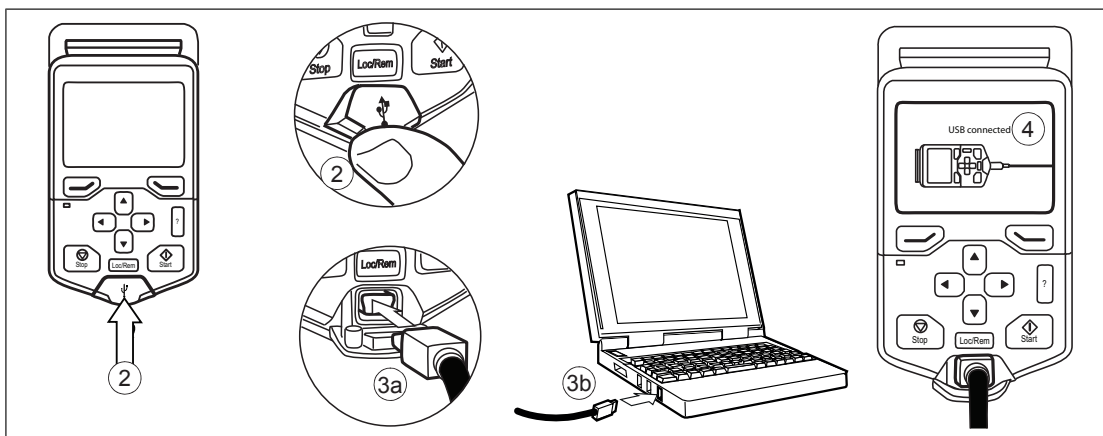

Panel bus (Control of several units from one control panel)

One control panel (or PC) can be used to control several drives (or inverter units, supply units etc.) by constructing a panel bus. This is done by daisy-chaining the panel connections of the drives. Some drives have the necessary (twin) panel connectors in the control panel holder; those that do not require the installation of an FDPI-02 module (available separately). For further information, see the hardware description and *FDPI-02 diagnostics and panel interface user's manual* ([3AJUA0000113618](#) [English]).

The maximum allowed length of the cable chain is 100 m (328 ft).

1. Connect the panel to one drive using an Ethernet (for example Cat 5e) cable.
 - Use Menu - Settings - Edit texts - Drive to give a descriptive name to the drive
 - Use parameter 49.01* to assign the drive with a unique node ID number
 - Set other parameters in group 49* if necessary
 - Use parameter 49.06* to validate any changes.

*The parameter group is 149 with supply (line-side), brake or DC/DC converter units. Repeat the above for each drive.

2. With the panel connected to one unit, link the units using Ethernet cables.

3. Switch on the bus termination on the drive that is farthest from the control panel in the chain.

- With drives that have the panel mounted on the front cover, move the terminating switch into the outer position.
- With an FDPI-02 module, move termination switch S2 into the TERMINATED position.

Make sure that bus termination is off on all other drives.

4. On the control panel, switch on the panel bus functionality (Options - Select drive - Panel bus). The drive to be controlled can now be selected from the list under Options - Select drive.

If a PC is connected to the control panel, the drives on the panel bus are automatically displayed in the Drive composer tool.

With twin connectors in the control panel holder:

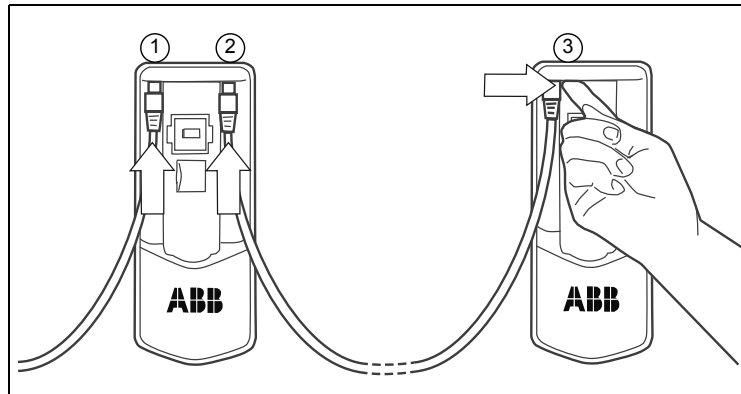
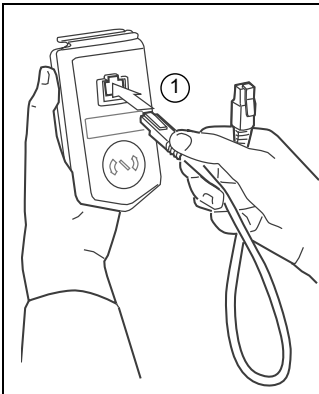

With FDPI-02 modules:

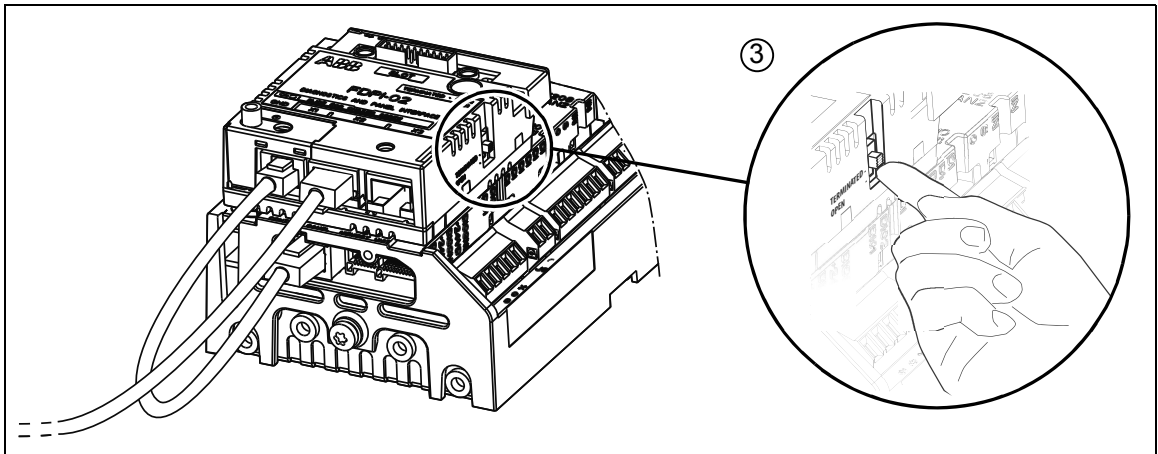
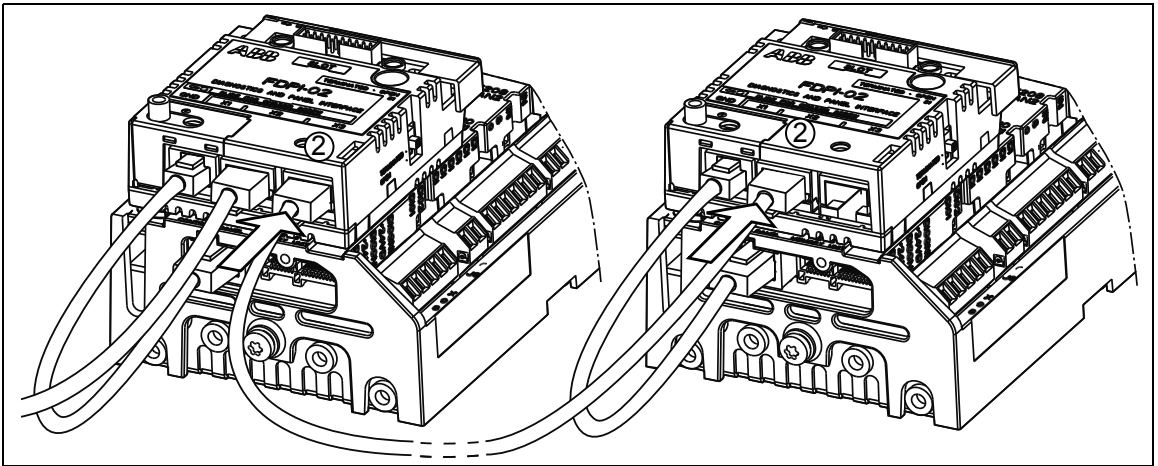
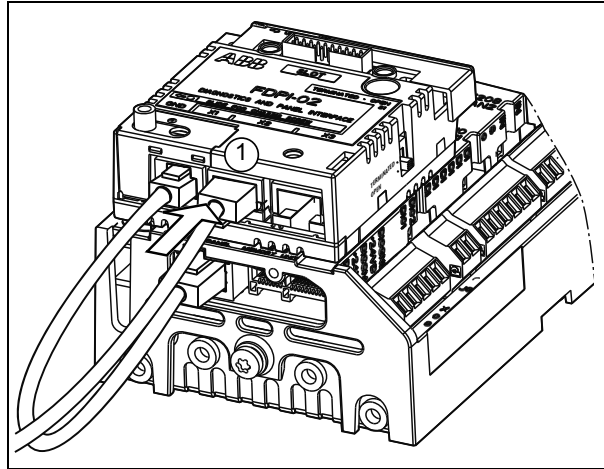
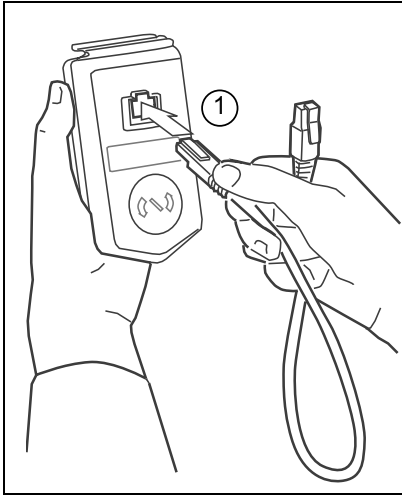

Installing option modules

■ Installing option modules



WARNING!

Obey the safety instructions of the drive. If you ignore them, injury or death, or damage to the equipment can occur.

Pay attention to the free space required by the cabling or terminals coming to the option modules.

1. Repeat the steps described in *Electrical safety precautions (page 18)*.
2. Pull out the lock.

Note: The location of the lock depends on the module type.

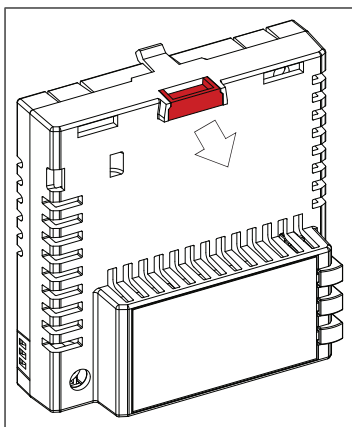

3. Install the module to a free option module slot on the control unit.
4. Push in the lock.

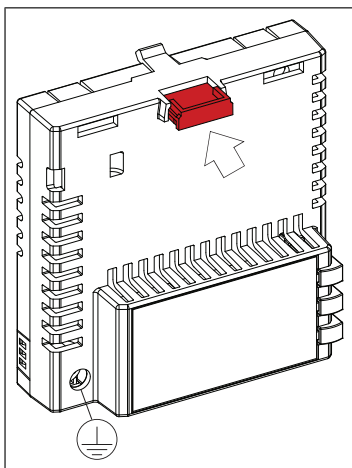

5. Tighten the grounding screw to a torque of 0.8 N·m (7 lbf·in).

Note: The screw tightens the connections and grounds the module. It is essential for fulfilling the EMC requirements and for proper operation of the module.



WARNING!

Do not use excessive force, or leave the screw too loose. Over-tightening can damage the screw or module. A loose screw can cause an operation failure.

6. Connect the wiring to the module. Obey the instructions given in the documentation of the module.

■ **Installation of an FSO-xx safety functions module beside the ZCU-12 control unit**

1. Stop the drive and do the steps in section [Electrical safety precautions \(page 18\)](#) before you start the work.
2. Attach the FSO-xx safety functions module to the mounting plate with four screws.
Note: Correct installation of the module enclosure grounding screw (2a) is essential for fulfilling the EMC requirements and for the correct operation of the module.
3. Tighten the grounding screw of the electronics to tightening torque of **0.8 N·m**.
Note: The grounding screw tightens the connections and grounds the module. It is essential for fulfilling the EMC requirements and the correct operation of the module.
4. Connect the data communication cable to connector X110 on the module and to connector X12 on the drive control unit.
5. Connect the Safe torque off four-wire cable to connector X111 on the module and to connector XSTO on the drive module control unit.
6. Connect the external +24 V power supply cable to connector X112.
7. Connect the other wires as shown in the user's manual of the module.



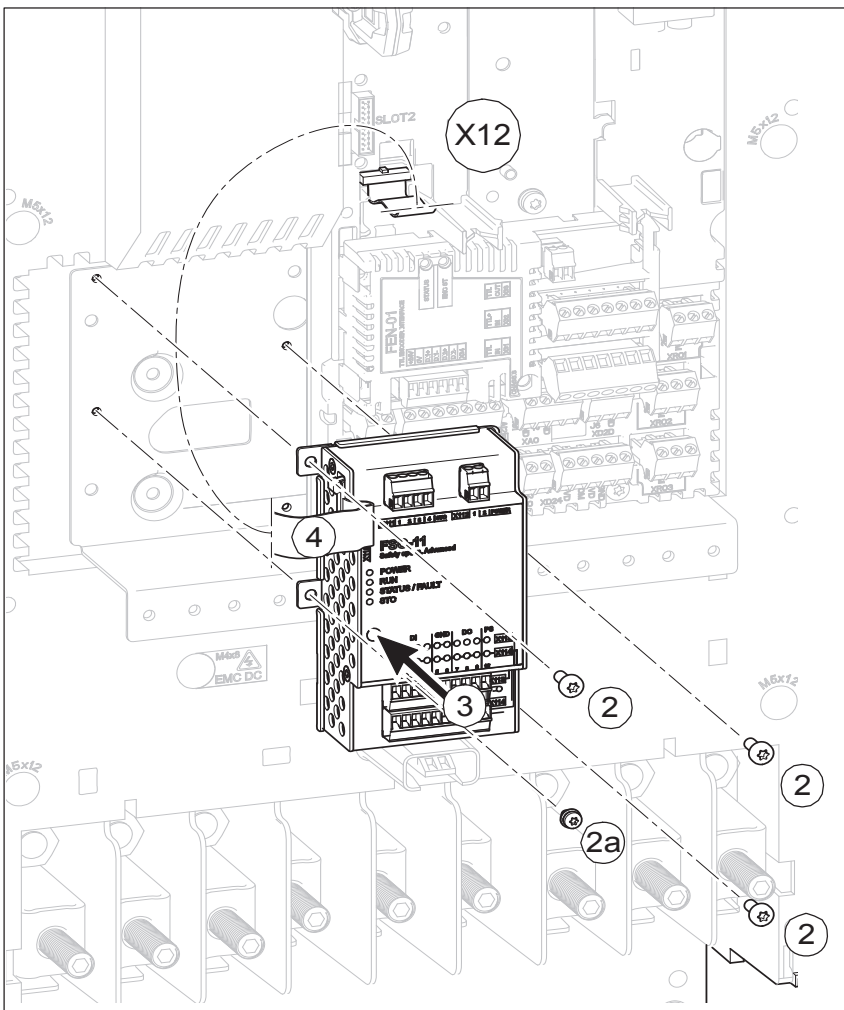

■ Installation of an FSO-xx safety functions module onto ZCU-14



WARNING!

Obey the instructions in chapter Safety instructions. If you ignore them, injury or death, or damage to the equipment can occur.

1. Stop the drive and do the steps in section *Electrical safety precautions (page 18)* before you start the work.
2. The FSO-xx comes with alternative bottom plates for mounting on different units. For mounting on the ZCU-14, the mounting points should be located at the short edges of the module as shown. Replace the bottom plate of the FSO-xx if necessary. For mounting on the ZCU-12, the mounting points should be located at the long edges. Replace the bottom plate of the FSO-xx if necessary.
3. Connect the data cable to connector X12 on the control unit.
4. Put the FSO-xx into its position on slot 2 of the control unit.
5. Tighten the FSO-xx electronics grounding screw to tightening torque **0.8 N·m**.
Note: The screw tightens the connections and grounds the module. It is essential for fulfilling the EMC requirements and for proper operation of the module.
6. Attach the module by the bottom plate with four screws.

7. Connect the other end of the data cable to connector X110 on the FSO-xx.
8. To complete the installation, refer to the instructions in the user's manual delivered with the FSO-xx.

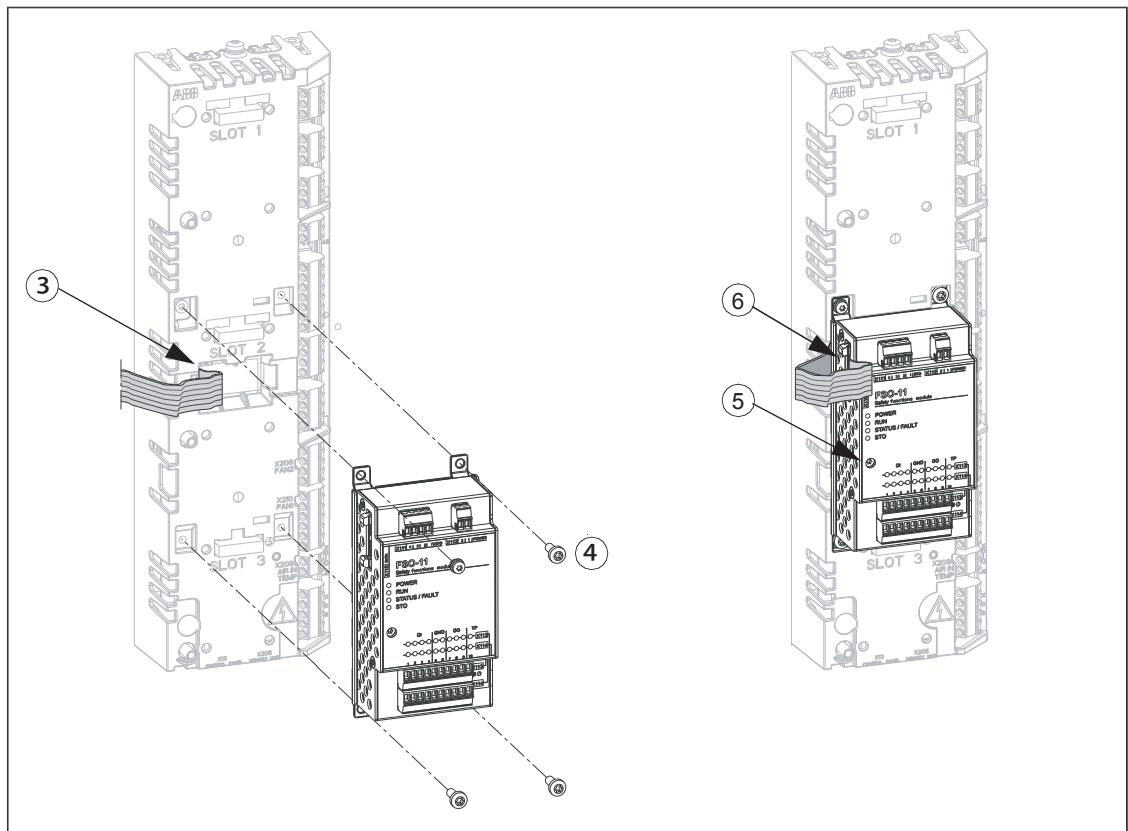

■ Safety functions module FSO-xx beside the ZCU-14 control unit

1. Stop the drive and do the steps in section [Electrical safety precautions \(page 18\)](#) before you start the work.
2. Attach the FSO-xx safety functions module to the mounting plate with four screws.
3. Tighten the mounting screw to **0.8 N·m**.
Note: The screw tightens the connections and grounds the module. It is essential for fulfilling the EMC requirements and for proper operation of the module
4. Connect the FSO-xx data cable to FSO-xx connector X110 and to connector X12 on the control unit.
5. To complete the installation, refer to the instructions in the user's manual delivered with the FSO-xx.



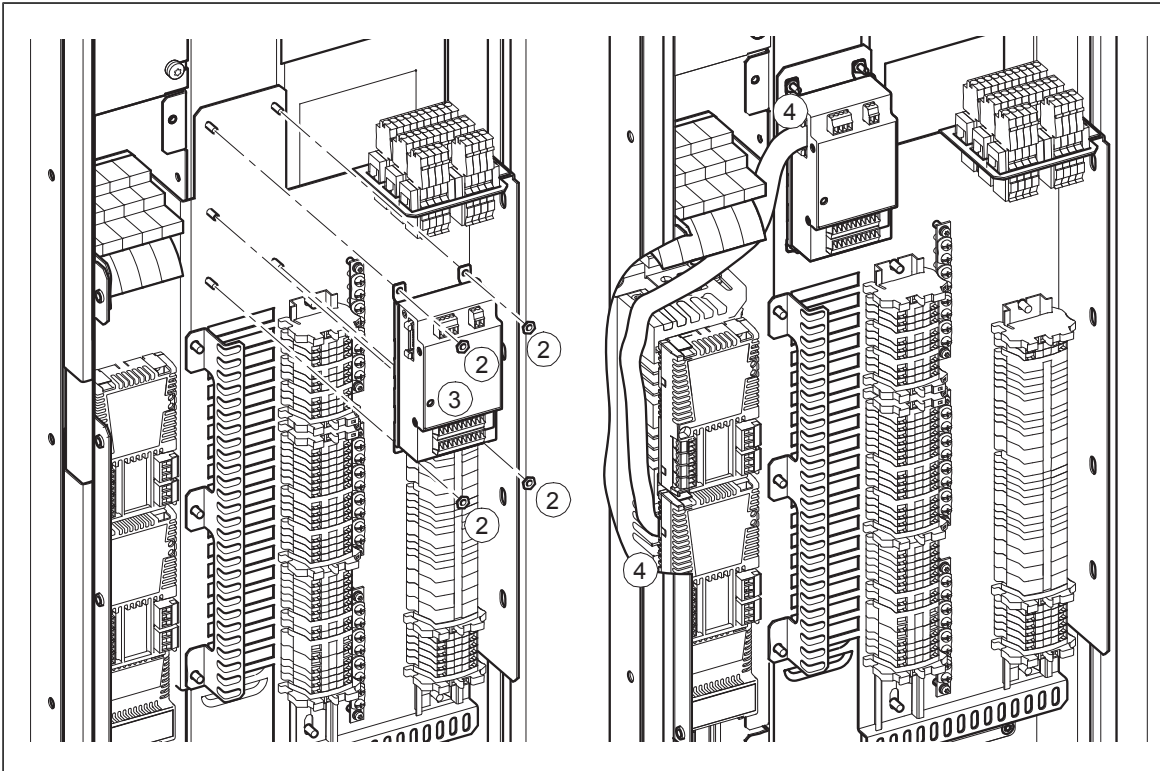



Control units of the drive

Contents of this chapter

This chapter

- describes the connections of the control unit(s) used in the drive,
- contains the specifications of the inputs and outputs of the control unit(s).

General

The drive utilizes ZCU-1x control units.

Frames R6...R9 contain the ZCU-12 control unit, frames R10 and R11 ZCU-14 control unit.

ZCU-12 layout

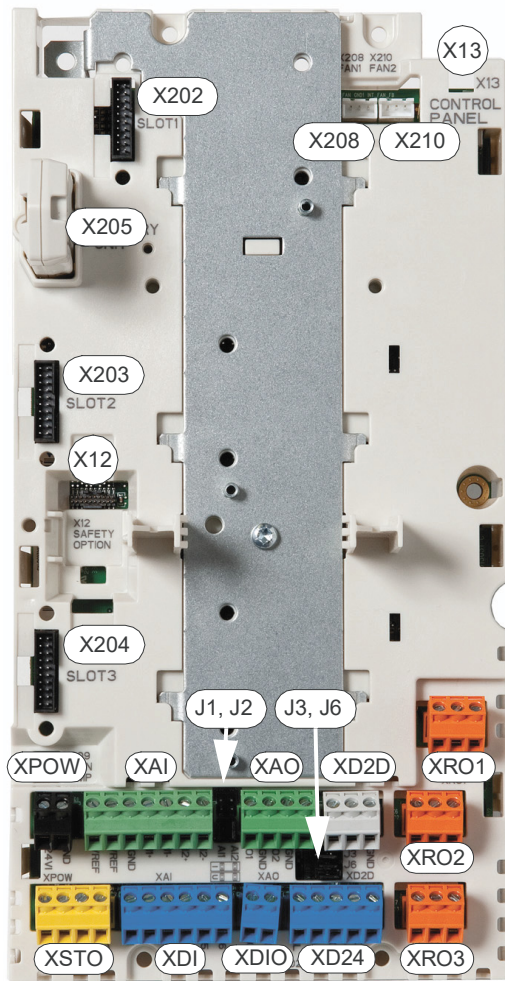

	Description
XAI	Analog inputs
XAO	Analog outputs
XDI	Digital inputs
XDIO	Digital input/outputs
XD24	Digital input interlock (DIIL) and +24 V output
XD2D	Drive-to-drive link
XPOW	External power input
XRO1	Relay output RO1
XRO2	Relay output RO2
XRO3	Relay output RO3
XSTO	Safe torque off connection
X12	Connection for FSO-xx safety functions module
X13	Control panel connection
X202	Option slot 1
X203	Option slot 2
X204	Option slot 3
X205	Memory unit connection (memory unit inserted in the picture)
X208	Cooling fan 1 connection
X210	Cooling fan 2 connection
J1, J2	Voltage/Current selection jumpers (J1, J2) for analog inputs
J3	Drive-to-drive link termination switch (J3)
J6	Common digital input ground selection switch (J6)

ZCU-14 layout

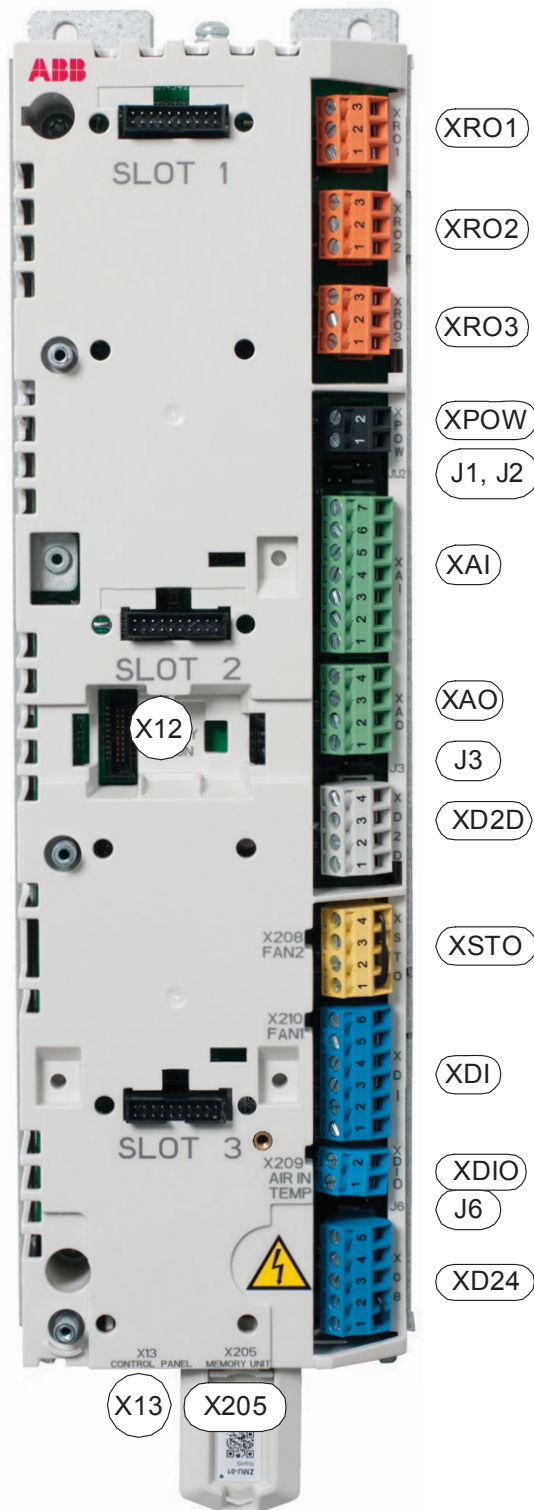

	Description
XPOW	External power input
XAI	Analog inputs
XAO	Analog outputs
XD2D	Drive-to-drive link
XRO1	Relay output RO1
XRO2	Relay output RO2
XRO3	Relay output RO3
XD24	Digital input interlock (DILL) and +24 V output
XDIO	Digital input/outputs
XDI	Digital inputs
XSTO	Safe torque off connection (inverter unit only). Note: This connection only acts as a true Safe torque off input when the ZCU is controlling an inverter unit. When the ZCU is controlling a supply unit, de-energizing the inputs will stop the unit but will not constitute a true safety function.
X12	Connection for FSO-xx safety functions module (inverter unit only).
X13	Control panel connection
X202	Option slot 1
X203	Option slot 2
X204	Option slot 3
X205	Memory unit connection (memory unit inserted in the drawing)
J1, J2	Voltage/Current selection jumpers (J1, J2) for analog inputs
J3	Drive-to-drive link termination switch (J3)
J6	Common digital input ground selection jumper (J6).

Default I/O diagram of the drive control unit (ZCU-1x)

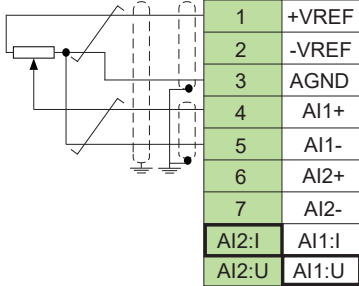
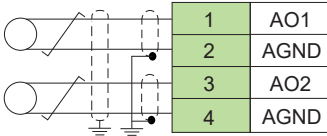
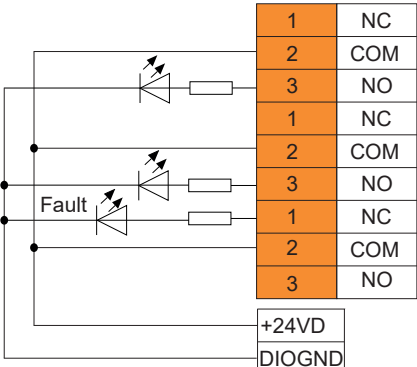
Connection	Term	Description								
XPOW External power input										
	+24VI	24 V DC, 2 A min. (without optional modules)								
	GND									
J1, J2, XAI Reference voltage and analog inputs										
	+VREF	10 V DC, R_L 1...10 kohm								
	-VREF	-10 V DC, R_L 1...10 kohm								
	AGND	Ground								
	AI1+	Speed reference								
	AI1-	0(2)...10 V, $R_{in} > 200$ kohm ¹⁾ selected by switch AI1.								
	AI2+	By default not in use.								
	AI2-	0(4)...20 mA, $R_{in} = 100$ ohm ²⁾								
	AI1: I	AI1/AI2 current/voltage selection								
	AI1: U									
XAO Analog outputs										
	AO1	Motor speed rpm								
	AGND	0...20 mA, $R_L < 500$ ohm								
	AO2	Motor current								
	AGND	0...20 mA, $R_L < 500$ ohm								
XD2D Drive-to-drive link										
<table border="1" data-bbox="437 1249 596 1384"> <tr><td>1</td><td>B</td></tr> <tr><td>2</td><td>A</td></tr> <tr><td>3</td><td>BGND</td></tr> <tr><td>4</td><td>Shield</td></tr> </table>	1	B	2	A	3	BGND	4	Shield	B	Master/follower, drive-to-drive or embedded fieldbus connection ³⁾
	1	B								
	2	A								
	3	BGND								
4	Shield									
A										
BGND										
Shield										
	J3	Drive-to-drive link termination ³⁾								
XRO1, XRO2, XRO3 Relay outputs										
	NC	Ready run								
	COM	250 V AC / 30 V DC								
	NO	2 A								
	NC	Running								
	COM	250 V AC / 30 V DC								
	NO	2 A								
	NC	Fault (-1)								
	COM	250 V AC / 30 V DC								
	NO	2 A								

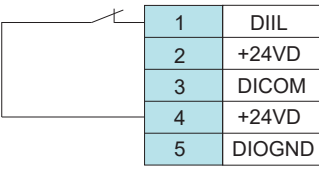
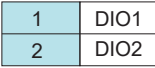
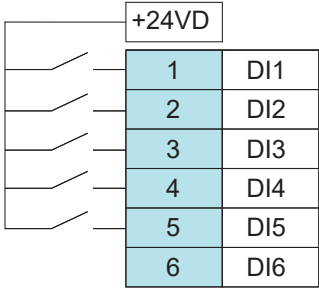
Connection	Term	Description
XD24 Auxiliary voltage output, digital interlock ⁴⁾		
	DIIL	Run enable ⁴⁾
	+24VD	+24 V DC 200 mA
	DICOM	Digital input ground
	+24VD	+24 V DC 200 mA ⁵⁾
	DIOGND	Digital input/output ground
XDIO Digital input/outputs		
	DIO1	Output: Ready run
	DIO2	Output: Running
	J6	Ground selection ⁶⁾
XDI Digital inputs		
	DI1	Stop (0) / Start (1)
	DI2	Forward (0) / Reverse (1)
	DI3	Reset
	DI4	Acc/Dec time select ⁷⁾
	DI5	Constant speed 1 (1 = On) ⁸⁾
	DI6	By default, not in use.
XSTO	Safe torque off circuits must be closed for the drive to start. ⁹⁾	
X12	Safety options connection	
X13	Control panel connection	
X205	Memory unit connection	

1) Current [0(4)...20 mA, $R_{in} = 100 \text{ ohm}$] or voltage [0(2)...10 V, $R_{in} > 200 \text{ kohm}$] input selected by switch AI1. Change of setting requires reboot of control unit.

2) Current [0(4)...20 mA, $R_{in} = 100 \text{ ohm}$] or voltage [0(2)...10 V, $R_{in} > 200 \text{ kohm}$] input selected by switch AI2. Change of setting requires reboot of control unit.

3) See section [The XD2D connector \(page 147\)](#)

4) See section [DIIL input \(page 147\)](#).

Total load capacity of these outputs is 4.8 W (200 mA at 24 V) minus the power taken by DIO1 and DIO2.

6) Determines whether DICOM is separated from DIOGND (ie. common reference for digital inputs floats; in practice, selects whether the digital inputs are used in current sinking or sourcing mode). See also [ZCU-1x ground isolation diagram \(page 151\)](#). DICOM=DIOGND ON: DICOM connected to DIOGND. OFF: DICOM and DIOGND separate.

7) 0 = Acceleration/deceleration ramps defined by parameters 23.12/23.13 in use. 1 = Acceleration/deceleration ramps defined by parameters 23.14/23.15 in use.

8) Constant speed 1 is defined by parameter 22.26.

9) See chapter [The Safe torque off function \(page 245\)](#).

The wire size accepted by all screw terminals (for both stranded and solid wire) is 0.5 ... 2.5 mm² (24...12 AWG). The torque is 0.5 N·m (5 lbf·in).

Additional information on the connections

External power supply for the control unit (XPOW)

The control unit is powered from a 24 V DC, 2 A supply through terminal block XPOW.

Using an external supply is recommended if

- the control unit needs to be kept operational during input power breaks, for example, because of continuous fieldbus communication
- immediate restart is needed after a power break (that is, no control unit power-up delay is allowed).

DI6 as a PTC sensor input

PTC sensors can be connected to this input for motor temperature measurement as follows. The sensor can alternatively be connected to FEN-xx encoder interface module or FPTC-xx thermistor protection module (option +L536) or PTC relay (option +L505). At the sensor end of the cable, leave the shields unconnected or ground them indirectly via a high-frequency capacitor with a few nanofarads, for example 3.3 nF / 630 V. The shield can also be grounded directly at both ends if they are in the same ground line with no significant voltage drop between the end points. See the firmware manual of the inverter unit for parameter settings.

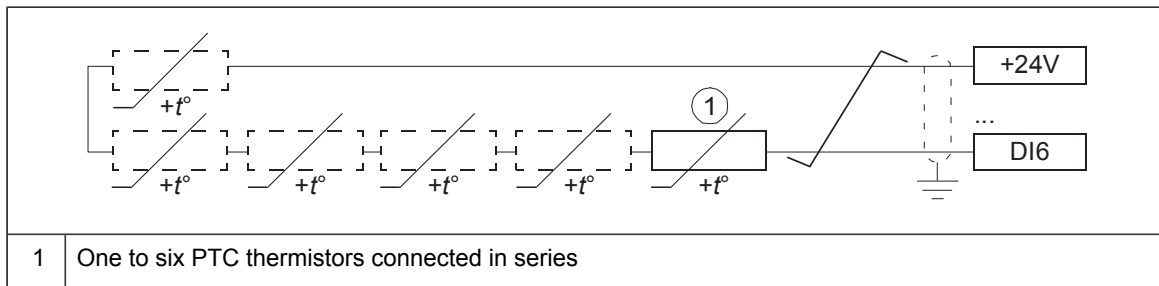

WARNING!

As the inputs pictured above are not insulated according to IEC 60664, the connection of the motor temperature sensor requires double or reinforced insulation between motor live parts and the sensor. If the assembly does not fulfill the requirement, protect the I/O board terminals against contact and do not connect them to other equipment, or isolate the temperature sensor from the I/O terminals. Make sure that the voltage does not exceed the maximum allowed voltage over the PTC sensor.

AI1 or AI2 as a Pt100, Pt1000, PTC or KTY84 sensor input

Sensors for motor temperature measurement can be connected between an analog input and output, an example connection is shown below. (Alternatively, you can connect the KTY to an FIO-11 or FAIO-01 analog I/O extension module or FEN-xx encoder interface module.) At the sensor end of the cable, leave the shields unconnected or ground them indirectly via a high-frequency capacitor with a few nanofarads, for example 3.3 nF / 630 V. The shield can also be grounded directly at both ends if they are in the same ground line with no significant voltage drop between the end points.

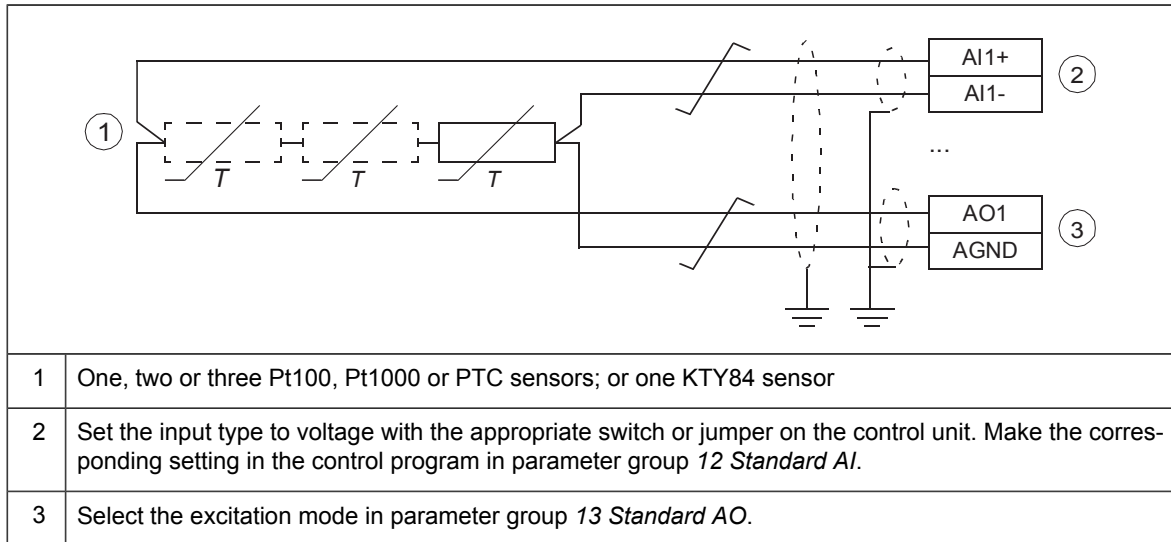
**WARNING!**

As the inputs pictured above are not insulated according to IEC/EN 60664, the connection of the motor temperature sensor requires double or reinforced insulation between motor live parts and the sensor. If the assembly does not fulfill the requirement, protect the I/O board terminals against contact and do not connect them to other equipment, or isolate the temperature sensor from the I/O terminals. Make sure that the current does not exceed the maximum allowed current through the Pt100/Pt1000 sensor.

■ DIIL input

The DIIL input is used for the connection of safety circuits. The input is parametrized to stop the unit when the input signal is lost.

Note: This input is NOT SIL or PI certified.

■ The XD2D connector

The XD2D connector provides an RS-485 connection that can be used for

- basic master/follower communication with one master drive and multiple followers,
- fieldbus control through the embedded fieldbus interface (EFB), or
- drive-to-drive (D2D) communication implemented by application programming.

See the firmware manual of the drive for the related parameter settings.

Enable bus termination on the units at the ends of the drive-to-drive link. Disable bus termination on the intermediate units.

Use shielded twisted-pair cable with a twisted pair for data and a wire or another pair for signal ground (nominal impedance 100 to 165 ohm, for example Belden 9842) for the wiring. For best immunity, ABB recommends high quality cable. Keep the cable as short as possible. Avoid unnecessary loops and parallel runs near power cables such as motor cables.

The following diagram shows the wiring between control units.

ZCU-12

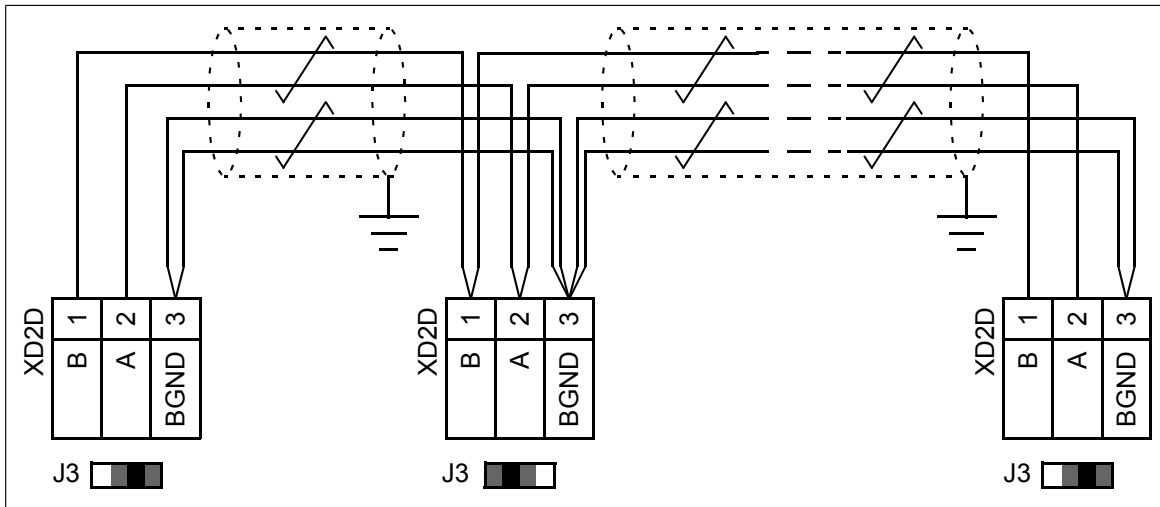

ZCU-14

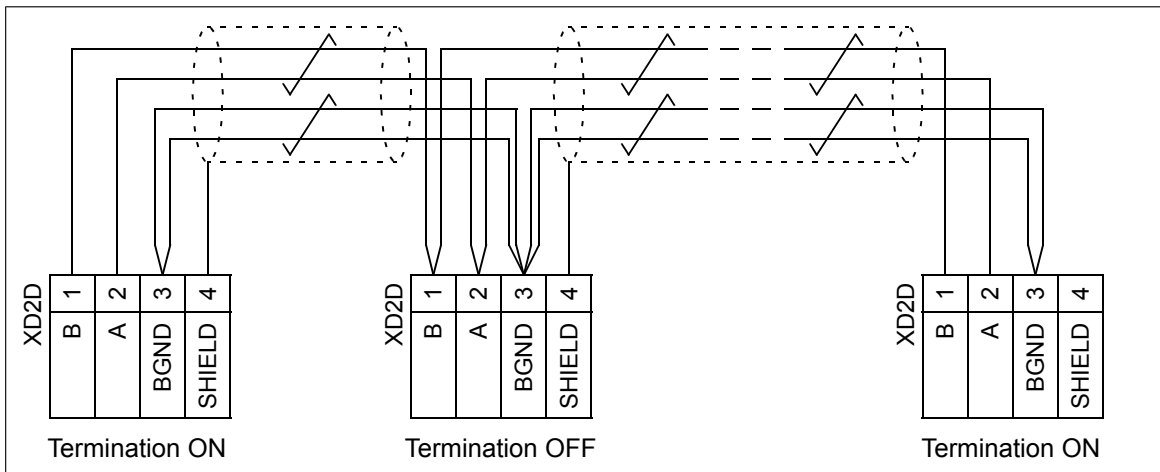

■ **Safe torque off (XSTO)**

See chapter *The Safe torque off function (page 245)*.

Note: The XSTO input only acts as a true Safe torque off input on the inverter control unit. De-energizing the IN1 and/or IN2 terminals of other units (supply, DC/DC converter, or brake unit) will stop the unit but not constitute a true safety function.

■ **FSO-xx safety functions module connection (X12)**

See the user manual of the FSO-xx module.

Connector data

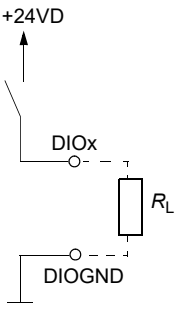
Power supply (XPOW)	Connector pitch 5 mm, wire size 2.5 mm ² 24 V ($\pm 10\%$) DC, 2 A External power input.
Relay outputs RO1...RO3 (XRO1...XRO3)	Connector pitch 5 mm, wire size 2.5 mm ² 250 V AC / 30 V DC, 2 A Protected by varistors
+24 V output (XD24:2 and XD24:4)	Connector pitch 5 mm, wire size 2.5 mm ² Total load capacity of these outputs is 4.8 W (200 mA / 24 V) minus the power taken by DIO1 and DIO2.
Digital inputs DI1...DI6 (XDI:1...XDI:6)	Connector pitch 5 mm, wire size 2.5 mm ² 24 V logic levels: "0" < 5 V, "1" > 15 V R_{in} : 2.0 kohm Input type: NPN/PNP (DI1...DI5), NPN (DI6) Hardware filtering: 0.04 ms, digital filtering up to 8 ms DI6 (XDI:6) can alternatively be used as an input for a PTC sensor. "0" > 4 kohm, "1" < 1.5 kohm. I_{max} : 15 mA (DI1...DI5), 5 mA (DI6)
Start interlock input DIIL (XD24:1)	Connector pitch 5 mm, wire size 2.5 mm ² 24 V logic levels: "0" < 5 V, "1" > 15 V R_{in} : 2.0 kohm Input type: NPN/PNP Hardware filtering: 0.04 ms, digital filtering up to 8 ms
Digital inputs/outputs DIO1 and DIO2 (XDIO:1 and XDIO:2) Input/output mode selection by parameters. DIO1 can be configured as a frequency input (0...16 kHz with hardware filtering of 4 microseconds) for 24 V level square wave signal (sinusoidal or other wave form cannot be used). DIO2 can be configured as a 24 V level square wave frequency output. See the firmware manual, parameter group 111/11.	Connector pitch 5 mm, wire size 2.5 mm ² <u>As inputs:</u> 24 V logic levels: "0" < 5 V, "1" > 15 V. R_{in} : 2.0 kohm. Filtering: 1 ms. <u>As outputs:</u> Total output current from +24VD is limited to 200 mA 
Reference voltage for analog inputs +VREF and -VREF (XAI:1 and XAI:2)	Connector pitch 5 mm, wire size 2.5 mm ² 10 V $\pm 1\%$ and -10 V $\pm 1\%$, R_{load} 1...10 kohm Maximum output current: 10 mA
Analog inputs AI1 and AI2 (XAI:4 ... XAI:7). Current/voltage input mode selection by jumpers	Connector pitch 5 mm, wire size 2.5 mm ² Current input: -20...20 mA, R_{in} = 100 ohm Voltage input: -10...10 V, R_{in} > 200 kohm Differential inputs, common mode range ± 30 V Sampling interval per channel: 0.25 ms Hardware filtering: 0.25 ms, adjustable digital filtering up to 8 ms Resolution: 11 bit + sign bit Inaccuracy: 1% of full scale range

150 Control units of the drive

Analog outputs AO1 and AO2 (XAO)	<p>Connector pitch 5 mm, wire size 2.5 mm² 0...20 mA, $R_{load} < 500 \text{ ohm}$ Frequency range: 0...300 Hz Resolution: 11 bit + sign bit Inaccuracy: 2% of full scale range</p>
XD2D connector	<p>Connector pitch 5 mm, wire size 2.5 mm² Physical layer: RS-485 Transmission rate: 8 Mbit/s Cable type: Shielded twisted-pair cable with a twisted pair for data and a wire or another pair for signal ground (nominal impedance 100 ... 165 ohm, for example Belden 9842) Maximum length of link: 50 m (164 ft) Termination by jumper</p>
Safe torque off connection (XSTO)	<p>Connector pitch 5 mm, wire size 2.5 mm² Input voltage range: -3...30 V DC Logic levels: "0" < 5 V, "1" > 17 V. Note: For the unit to start, both connections must be "1". This applies to all control units (including drive, inverter, supply, brake, DC/DC converter etc. control units), but true Safe torque off functionality is only achieved through the XSTO connector of the drive/inverter control unit. EMC (immunity) according to IEC 61326-3-1</p>
Control panel connection (X13)	<p>Connector: RJ-45 Cable length < 3 m</p>
<p>The terminals of the control unit fulfill the Protective Extra Low Voltage (PELV) requirements. The PELV requirements of a relay output are not fulfilled if a voltage higher than 48 V is connected to the relay output.</p>	

■ ZCU-1x ground isolation diagram

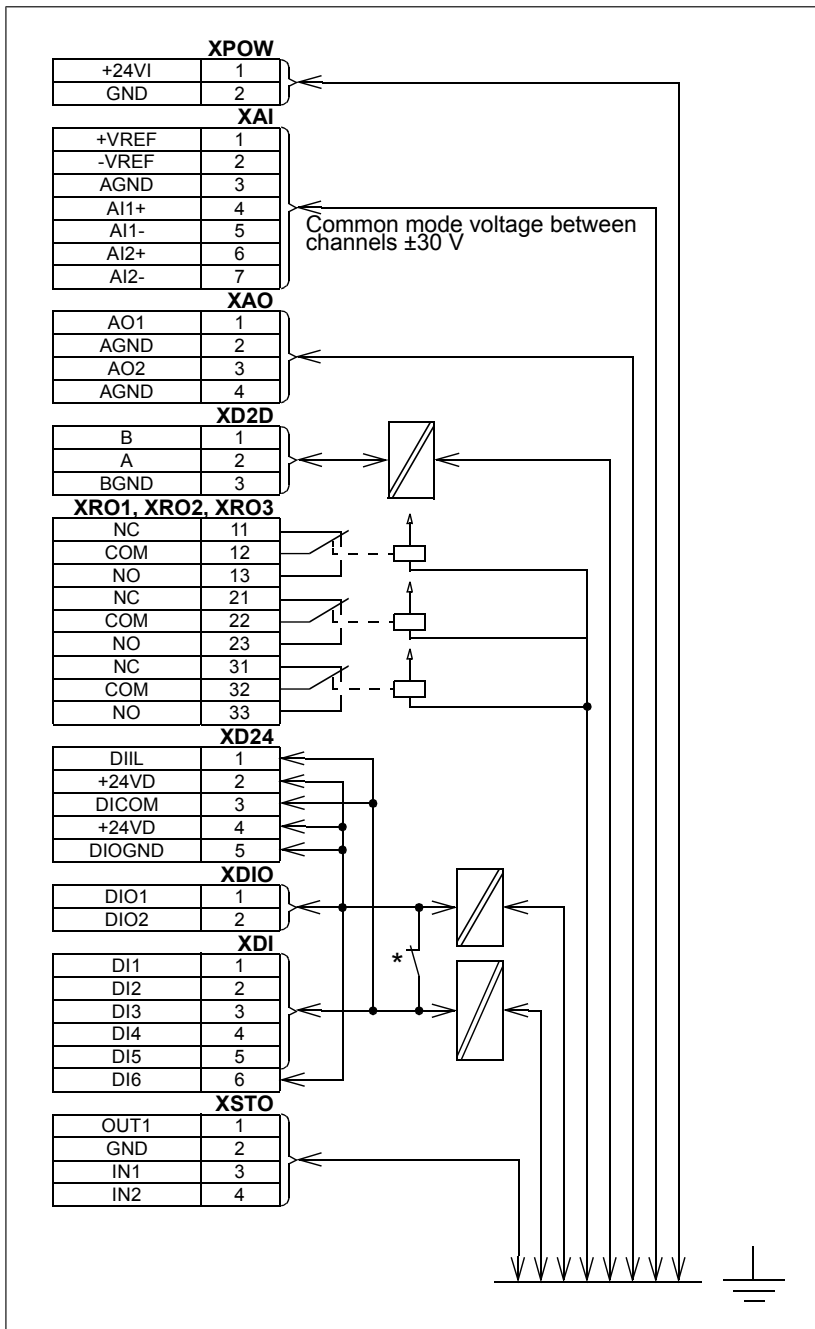

* Ground selector (J6) settings

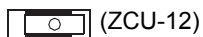

(ZCU-12)

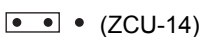

(ZCU-14)

All digital inputs share a common ground (DICOM connected to DIOGND). This is the default setting.

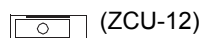

(ZCU-12)

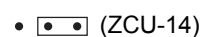

(ZCU-14)

Ground of digital inputs DI1...DI5 and DIIL (DICOM) is isolated from DIO signal ground (DIOGND).

Isolation voltage 50 V.

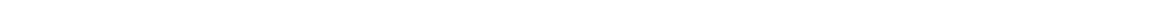

8

Installation checklist

Contents of this chapter

This chapter contains a checklist of the mechanical and electrical installation of the drive.

Checklist

Examine the mechanical and electrical installation of the drive before start-up. Go through the checklist together with another person.



WARNING!

Obey the safety instructions of the drive. If you ignore them, injury or death, or damage to the equipment can occur. If you are not a qualified electrical professional, do not do installation or maintenance work.



WARNING!

Stop the drive and do the steps in section [Electrical safety precautions \(page 18\)](#) before you start the work.

Make sure that ...	<input checked="" type="checkbox"/>
The ambient operating conditions meet the drive ambient conditions specification, and enclosure rating (IP code or UL enclosure type).	<input type="checkbox"/>
The supply voltage matches the nominal input voltage of the drive. See the type designation label.	<input type="checkbox"/>
The insulation resistance of the input power cable, motor cable and motor is measured according to local regulations and the manuals of the drive.	<input type="checkbox"/>
The drive cabinet is attached to the floor, and if necessary due to vibration etc, also by its top to the wall or roof.	<input type="checkbox"/>
The drive module is fastened properly to the enclosure.	<input type="checkbox"/>
The cooling air flows freely in and out of the drive.	<input type="checkbox"/>

154 Installation checklist

Make sure that ...	<input checked="" type="checkbox"/>
<u>If the drive is connected to a network other than a symmetrically grounded TN-S system:</u> You have done all the required modifications (for example, you may need to disconnect the EMC filter or ground-to-phase varistor). See the electrical installation instructions.	<input type="checkbox"/>
There is an adequately sized protective earth (ground) conductor(s) between the drive and the switchboard, the conductor is connected to correct terminal, and the terminal is tightened to the correct torque. Proper grounding has also been measured according to the regulations.	<input type="checkbox"/>
The input power cable is connected to the correct terminals, the phase order is correct, and the terminals are tightened to the correct torque.	<input type="checkbox"/>
There is an adequately sized protective earth (ground) conductor between the motor and the drive, and the conductor is connected to the correct terminal, and the terminal is tightened to the correct torque. Proper grounding has also been measured according to the regulations.	<input type="checkbox"/>
The motor cable is connected to the correct terminals, the phase order is correct, and the terminals are tightened to the correct torque.	<input type="checkbox"/>
The motor cable is routed away from other cables.	<input type="checkbox"/>
No power factor compensation capacitors are connected to the motor cable.	<input type="checkbox"/>
<u>If an external brake resistor is connected to the drive:</u> There is an adequately sized protective earth (ground) conductor between the brake resistor and the drive, and the conductor is connected to the correct terminal, and the terminals are tightened to the correct torque. Proper grounding has also been measured according to the regulations.	<input type="checkbox"/>
<u>If an external brake resistor is connected to the drive:</u> The brake resistor is connected to the correct terminals, and the terminals are tightened to the correct torque.	<input type="checkbox"/>
<u>If an external brake resistor is connected to the drive:</u> The brake resistor cable is routed away from other cables.	<input type="checkbox"/>
The control cables are connected to the correct terminals, and the terminals are tightened to the correct torque.	<input type="checkbox"/>
The voltage setting of the auxiliary voltage transformers (if any) is correct. See the electrical installation instructions.	<input type="checkbox"/>
<u>If a drive bypass connection will be used:</u> The direct-on-line contactor of the motor and the drive output contactor are either mechanically and/or electrically interlocked, that is, they cannot be closed at the same time. A thermal overload device must be used for protection when bypassing the drive. Refer to local codes and regulations.	<input type="checkbox"/>
There are no tools, foreign objects or dust from drilling inside the drive.	<input type="checkbox"/>
The area in front of the drive is clean: the drive cooling fan cannot draw any dust or dirt inside.	<input type="checkbox"/>
Cover(s) of the motor connection box are in place. Cabinet shrouds are in place and doors are closed.	<input type="checkbox"/>
The motor and the driven equipment are ready for power-up.	<input type="checkbox"/>

9

Start-up

Contents of this chapter

This chapter contains the start-up procedure of the drive.

Start-up procedure

The tasks which are needed in certain cases only are marked with underlining, and option codes are given in brackets. Default device designations (if any) are given in brackets after the name, for example “main switch-disconnector (Q1)”. The same device designations are typically also used in the circuit diagrams.

These instructions cannot and do not cover all possible start-up tasks of a customized drive. Always refer to the delivery-specific circuit diagrams when proceeding with the startup.



WARNING!

Obey the safety instructions of the drive. If you ignore them, injury or death, or damage to the equipment can occur. If you are not a qualified electrical professional, do not do installation or maintenance work.

Note: For certain options (such as functional safety options +Q950, +Q951, +Q952, +Q957, +Q963, +Q964, +Q978, +Q979), additional start-up instructions are given in their separate manuals. See the listing of manuals inside the front cover.

Action	<input checked="" type="checkbox"/>
Safety	
 WARNING! Obey the safety instructions during the start-up procedure. See chapter <i>Safety instructions</i> (page 15).	<input type="checkbox"/>
Basic checks with no voltage connected	
Check the mechanical and electrical installation of the drive. See <i>Installation checklist</i> (page 153).	<input type="checkbox"/>
Drives with <u>ground fault monitoring for IT (ungrounded) systems (option +Q954)</u> : Adjust the settings of the ground fault monitor to suit the installation. See the circuit diagrams of the delivery and <i>IRDH275B Ground Fault Monitor Operating Manual</i> by Bender (code: TGH1386en).	<input type="checkbox"/>
For drives with Pt100 relays (option +(n)L506): <ul style="list-style-type: none"> •Check the connections against the circuit diagrams of the delivery. •Set the alarm and trip levels of the Pt100 relays. Set the alarm and trip levels of the Pt100 relay as low as possible based on the operating temperature and test results of the machine. The trip level can be set, for example, 10 °C higher than what the temperature of the machine is at maximal load in the maximum environmental temperature. ABB recommends to set the operating temperatures of the relay, typically for example, as follows: <ul style="list-style-type: none"> •120...140 °C when only tripping is in use •alarm 120...140 °C and trip 130...150 °C when both alarm and tripping are used. 	<input type="checkbox"/>
Connecting voltage to the input terminals and auxiliary circuit	
Make sure that it is safe to connect voltage. Make sure that: <ul style="list-style-type: none"> •cabinet doors are closed •nobody is working on the drive or circuits that have been wired from outside into the drive cabinet •the cover of the motor terminal box is in place. 	<input type="checkbox"/>
Close the main switch-disconnector (Q1).	<input type="checkbox"/>
Setting up the drive parameters	
Setup the drive control program. See the appropriate start-up guide and/or firmware manual. There is a separate start-up guide only for some control programs. For drives with resistor braking (optional): see also section <i>Brake system start-up</i> in chapter <i>Resistor braking</i> . For option +N7502, see also <i>SynRM motor control program (option +N7502) for ACS880-01, ACS880-07, ACS850-04 and ACQ810-04 drives supplement</i> (3AXD50000026332 [English]). For drives with ABB sine filter, check that bit 1 (ABB sine filter) of parameter 95.15 <i>Special HW settings</i> is activated. For other sine filters, see <i>Sine filter hardware manual</i> (3AXD50000016814 [English]). For drives with ABB motors in explosive atmospheres, see also <i>ACS880 drives with ABB motors in explosive atmospheres</i> (3AXD50000019585 [English]). If you need more information on the use of the control panel, see <i>ACS-AP-X Assistant control panels user's manual</i> (3AUA0000085685 (English)).	<input type="checkbox"/>
Powering up the drive	
Drive with the <u>emergency stop category 0 (option +Q951) and category 1 (option +Q52)</u> : Reset the emergency stop relay (A61) with the emergency stop reset button (S62). Otherwise you cannot close the main contactor.	<input type="checkbox"/>
Drive with the <u>emergency stop category 0 (option +Q963) and category 1 (option +Q964)</u> : Reset the emergency stop relay [A61] with the emergency stop reset button [S62]. Otherwise you cannot start the drive because the STO signal circuit is open.	<input type="checkbox"/>
Drives with <u>main contactor (Q2, option +F250)</u> : Close the main contactor by turning the operating switch on the cabinet door from OFF into ON position.	<input type="checkbox"/>
Perform the first start of the drive and motor.	<input type="checkbox"/>
Stop the motor and drive.	<input type="checkbox"/>



Action	<input checked="" type="checkbox"/>
<u>Drives with a fieldbus adapter module (optional)</u> : Set the fieldbus parameters. Activate the appropriate assistant (if present) in the control program, or see the user's manual of the fieldbus adapter module, and the drive firmware manual. Check that the communication works between the drive and the PLC.	<input type="checkbox"/>
<u>Drives with an encoder interface module (optional)</u> : Set the encoder parameters. Activate the appropriate assistant (if present) in the control program, or see the user's manual of the encoder interface module, and the drive firmware manual.	<input type="checkbox"/>
On-load checks	
Check that the cooling fans rotate freely in the right direction, and the air flows upwards. A paper sheet set on the intake (door) gratings stays. The fans run noiselessly.	<input type="checkbox"/>
Check that the motor starts, stops and follows the speed reference in the correct direction when controlled with the control panel.	<input type="checkbox"/>
Check that the motor starts, stops and follows the speed reference in the correct direction when controlled through the customer-specific I/O or fieldbus.	<input type="checkbox"/>
<u>Drives in which the Safe torque off control circuit is in use</u> : Test and validate the operation of the Safe torque off function. See section <i>Start-up including validation test (page 252)</i> .	<input type="checkbox"/>
<u>Drives with an emergency stop circuit (options +Q951, +Q952, +Q963, +Q964, +Q978 and +Q979)</u> : Test and validate the operation of the emergency-stop circuit. See the delivery specific circuit diagrams and wiring, start-up and operating instructions of the option.	<input type="checkbox"/>
<u>Drives with the Prevention of unexpected start-up with safety relay (option +Q957)</u> : Test and validate the operation of the Prevention of unexpected start-up circuit. See the delivery specific circuit diagrams and wiring, start-up and operating instructions of the option.	<input type="checkbox"/>
<u>Drives with the Prevention of unexpected start-up with FSO-xx (option +Q950)</u> : Test and validate the operation of the Prevention of unexpected start-up circuit. See the delivery specific circuit diagrams and wiring, start-up and operating instructions of the option.	<input type="checkbox"/>





10

Fault tracing

Contents of this chapter

This chapter describes the fault tracing possibilities of the drive.

LEDs

This table shows the LEDs visible on the control panel mounting platform on cabinet door.

Where	LED	Color	When the LED is lit
Control panel mounting platform	POWER	Green	Control unit is powered and +15 V is supplied to the control panel
	FAULT	Red	Drive in fault state

Warning and fault messages

See the firmware manual for the descriptions, causes and remedies of the control program warning and fault messages.



Maintenance

Contents of this chapter

This chapter contains maintenance instructions.

Maintenance intervals

The tables below show the maintenance tasks which can be done by the end user. The complete maintenance schedule is available on the Internet (www.abb.com/driveservices). For more information, consult your local ABB Service representative (www.abb.com/searchchannels).

The maintenance and component replacement intervals are based on the assumption that the equipment is operated within the specified ratings and ambient conditions. ABB recommends annual drive inspections to ensure the highest reliability and optimum performance.

Note: Long term operation near the specified maximum ratings or ambient conditions may require shorter maintenance intervals for certain components. Consult your local ABB Service representative for additional maintenance recommendations.

■ Descriptions of symbols

Action	Description
I	Inspection (visual inspection and maintenance action if needed)
P	Performance of on/off-site work (commissioning, tests, measurements or other work)
R	Replacement

■ Recommended annual maintenance actions by the user

ABB recommends these annual inspections to ensure the highest reliability and optimum performance.

Recommended annual actions by the user	Annually
Connections and environment	
Cabinet door filters IP54	R
Quality of supply voltage	P
Spare parts	
Spare parts	I
DC circuit capacitors reforming, spare modules and spare capacitors	P
Inspections by the user	
IP22 and IP42 air inlet and outlet meshes	I
Tightness of terminals	I
Dustiness, corrosion and temperature	I
Heat sink cleaning	I
Other	
ABB-SACE Air circuit breaker maintenance	I

■ **Recommended maintenance intervals after start-up**

Component	Years from start-up						
	3	6	9	12	15	18	21
Cooling							
Main cooling fan							
Main cooling fan (R6 to R9) LONG-LIFE			R			R	
Main cooling fan (R10 and R11) *			R			R	
Auxiliary cooling fan							
Auxiliary cooling fan for circuit boards (R6 to R9) LONG-LIFE			R			R	
Auxiliary cooling fan IP55 (R8 and R9) LONG-LIFE			R			R	
Circuit board compartment cooling fans (R10 and R11) LONG-LIFE			R			R	
Cabinet cooling fan							
Internal LONG-LIFE 50 Hz			R			R	
Internal LONG-LIFE 60 Hz		R		R		R	
Door LONG-LIFE 50 Hz			R			R	
Door LONG-LIFE 60 Hz			R			R	
IP54 50 Hz *			R			R	
IP54 60 Hz *		R		R		R	
xSIN filter cooling fan							
Filter cooling fan			R			R	
* Fan has always been of type LONG-LIFE							
Aging							
ZCU control unit battery (real-time clock)		R		R		R	
Control panel battery (real-time clock)			R			R	
4FPS10000239703							

Cabinet

■ Cleaning the interior of the cabinet



WARNING!

Obey the safety instructions of the drive. If you ignore them, injury or death, or damage to the equipment can occur. If you are not a qualified electrical professional, do not do installation or maintenance work.



WARNING!

Use a vacuum cleaner with antistatic hose and nozzle, and wear a grounding wristband. Using a normal vacuum cleaner creates static discharges which can damage circuit boards.

1. Stop the drive and do the steps in section *Electrical safety precautions (page 18)* before you start the work.
2. Open the cabinet door.
3. Clean the interior of the cabinet. Use a vacuum cleaner and a soft brush.
4. Clean the air inlets of the fans and air outlets of the modules (top).
5. Clean the air inlet gratings (if any) on the door.
6. Close the door.

■ Cleaning the door air inlets (IP22 and IP42)

Check the dustiness of the air inlet meshes. If the dust cannot be removed by vacuum cleaning from outside through the grating holes with a small nozzle, proceed as follows:

1. Stop the drive and do the steps in section *Electrical safety precautions (page 18)* before you start the work.
2. Remove the fasteners at the top of the grating.
3. Lift the grating and pull it away from the door.
4. Vacuum clean or wash the grating on both sides.
5. Reinstall the grating in reverse order.

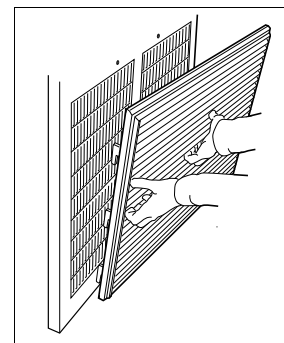
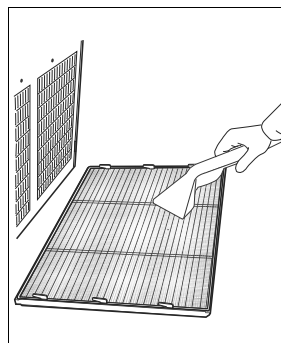
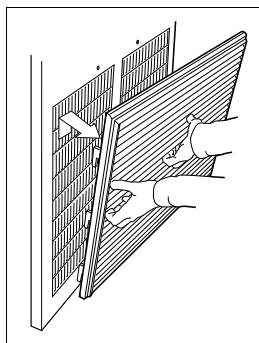
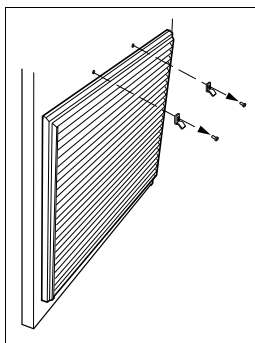

■ Replacing the inlet door filters (IP54)

1. Stop the drive and do the steps in section *Electrical safety precautions (page 18)* before you start the work.
2. Remove the fasteners at the top of the grating.
3. Lift the grating and pull it away from the door.
4. Remove the air filter mat.
5. Place the new filter mat in the grating the metal wire side facing the door.
6. Reinstall the grating in reverse order.

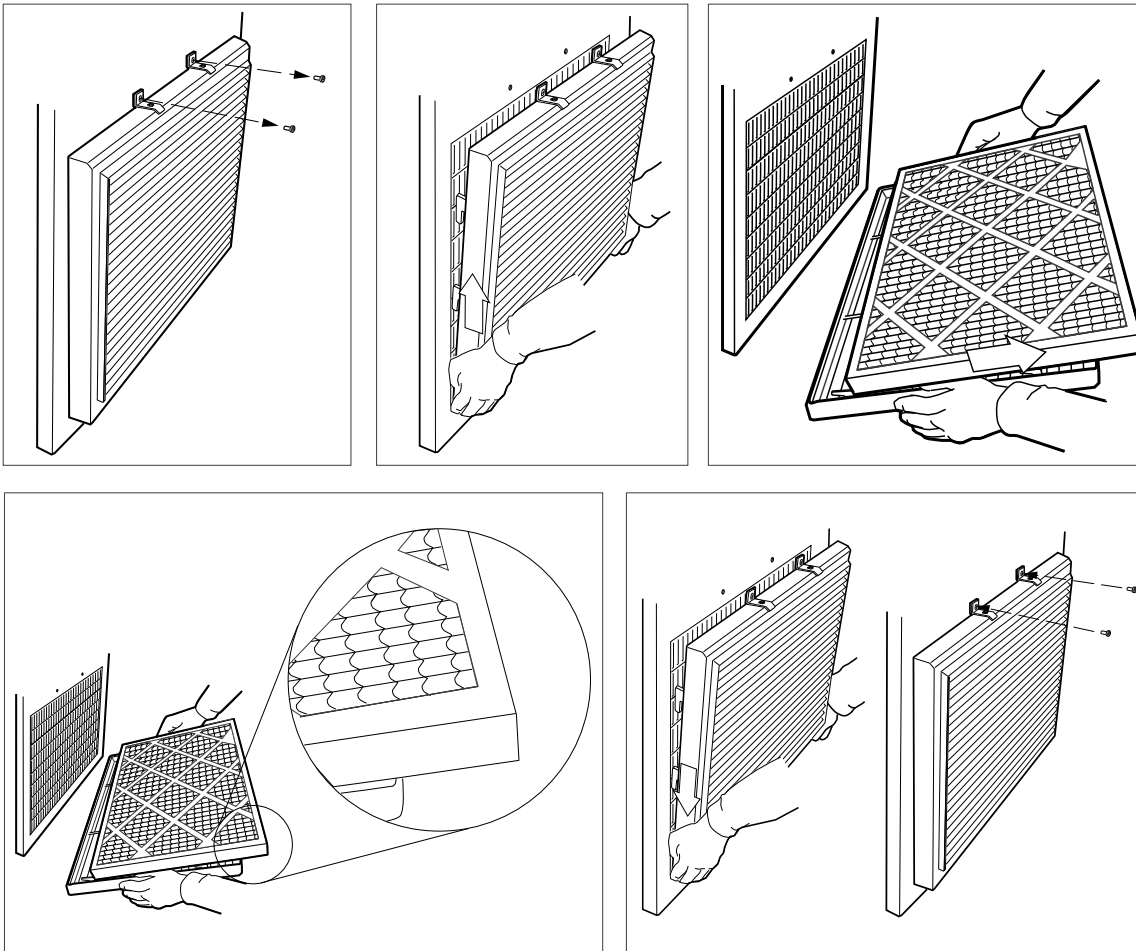

■ Cleaning the roof outlet filters (IP54)

The outlet filters on the roof of IP54 units can be accessed by pulling the gratings upwards.

■ Replacing the outlet (roof) filters (IP54)

1. Remove the front and back gratings of the fan cubicle by lifting them upwards.
 2. Remove the air filter mat.
 3. Place the new filter mat in the grating.
 4. Reinstall the gratings in reverse order.
-

Cleaning the heatsink

The drive module heatsink fins pick up dust from the cooling air. The drive runs into overtemperature warnings and faults if the heatsink is not clean. When necessary, clean the heatsink as follows.

**WARNING!**

Use the required personal protective equipment. Wear protective gloves and long sleeves. Some parts have sharp edges.

**WARNING!**

Use a vacuum cleaner with antistatic hose and nozzle, and wear a grounding wristband. Using a normal vacuum cleaner creates static discharges which can damage circuit boards.

1. Stop the drive and do the steps in section *Electrical safety precautions (page 18)* before you start the work.
2. Remove the drive module from the cabinet.
3. Remove the module cooling fan(s). See the separate instructions.
4. Blow dry, clean and oil-free compressed air from bottom to top and simultaneously use a vacuum cleaner at the air outlet to trap the dust. If there is a risk of dust entering adjoining equipment, do the cleaning in another room.
5. Reinstall the cooling fan.

Fans

■ Replacing cooling fans

The lifespan of the cooling fans of the drive depends on the running time, ambient temperature and dust concentration. See the firmware manual for the actual signal which indicates the running time of the cooling fan. Reset the running time signal after fan replacement.

Replacement fans are available from ABB. Do not use other than ABB specified spare parts.

■ Replacing the cabinet “door” fans



WARNING!

Obey the safety instructions of the drive. If you ignore them, injury or death, or damage to the equipment can occur.

1. Stop the drive and do the steps in section *Electrical safety precautions (page 18)* before you start the work.
2. Remove the mounting plate above the fan.
3. Loosen the four mounting screws of the fan mounting plate.
4. Lift the mounting plate upwards.
5. Unplug the power supply wires.
6. Lift the fan mounting plate off.
7. Remove the fan from the mounting plate.
8. Install the new fan in reverse order.

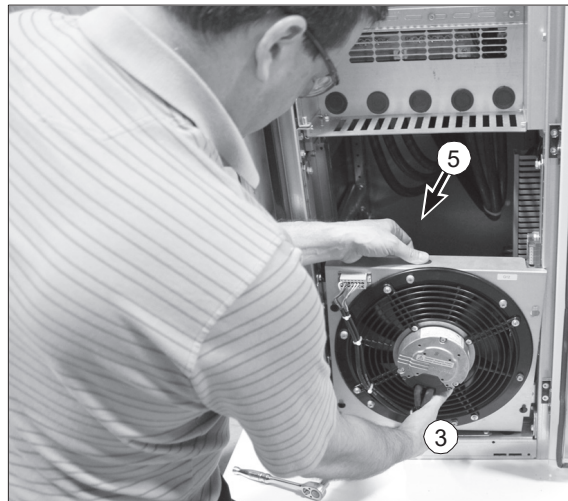

■ Replacing the cabinet fans (frames R6 to R9)

1. Stop the drive and do the steps in section [Electrical safety precautions \(page 18\)](#) before you start the work.
2. For removing the fan mounting plate, see section [Replacing the drive module \(frames R6 to R8\) \(page 176\)](#) (steps 1 to 3 and 13) or section [Replacing the drive module \(frame R9\) on page 181](#) (steps 1, 9 and 10). For frame R9 with option +C129, see also below:

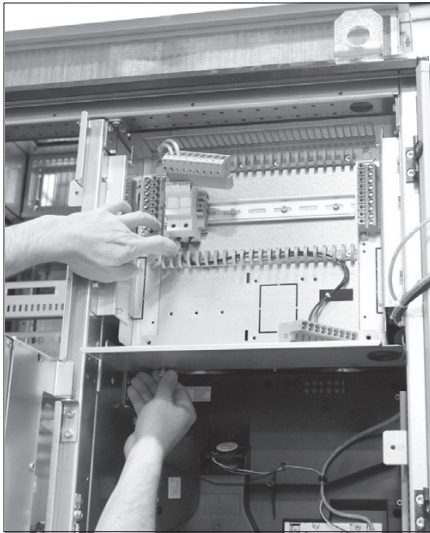

3. Remove the fan from the mounting plate.
 4. Install the new fan in reverse order.
-

■ Replacing the drive module main fans (frames R6 to R8)



WARNING!

Obey the safety instructions of the drive. If you ignore them, injury or death, or damage to the equipment can occur.

1. Stop the drive and do the steps in section *Electrical safety precautions (page 18)* before you start the work.
2. Slide the drive module forward as described under *Replacing the drive module (frames R6 to R8) (page 176)*
3. Undo the mounting screws of the fan mounting plate (view from bottom below).
4. Pull the fan mounting plate down from the side edge.
5. Unplug the power supply wires.
6. Lift the fan mounting plate off.
7. Remove the fan from the mounting plate.
8. Install the new fan in reverse order.
9. Reset the counter (if used) in group 5 in the primary control program.

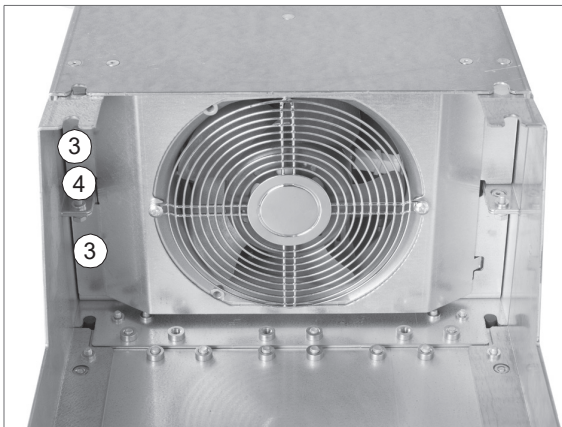

■ Replacing the auxiliary cooling fan of the drive module (frames R6 to R9)

**WARNING!**

Obey the safety instructions of the drive. If you ignore them, injury or death, or damage to the equipment can occur.

1. Stop the drive and do the steps in section *Electrical safety precautions (page 18)* before you start the work.
2. Unplug the power supply wires from the control unit terminal X208:FAN2.
3. Lift the fan up.
4. Install the new fan in reverse order. Make sure that the arrow on the fan points up.
5. Reset the counter (if used) in group 5 in the primary control program.

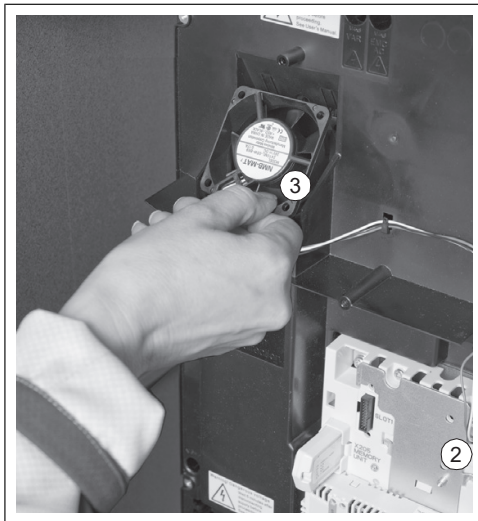

■ Replacing the drive module main fans (frame R9)



WARNING!

Obey the safety instructions of the drive. If you ignore them, injury or death, or damage to the equipment can occur.

1. Stop the drive and do the steps in section *Electrical safety precautions (page 18)* before you start the work.
2. Slide the drive module forward as described under *Replacing the drive module (frame R9) on page x*.
3. Undo the two mounting screws of the fan mounting plate (view from drive module bottom below).
4. Turn the mounting plate downwards.
5. Disconnect the fan power supply wires.
6. Remove the fan mounting plate.
7. Remove the fan by undoing the two mounting screws.
8. Install the new fan in reverse order.
9. Reset the counter (if used) in group 5 in the primary control program.

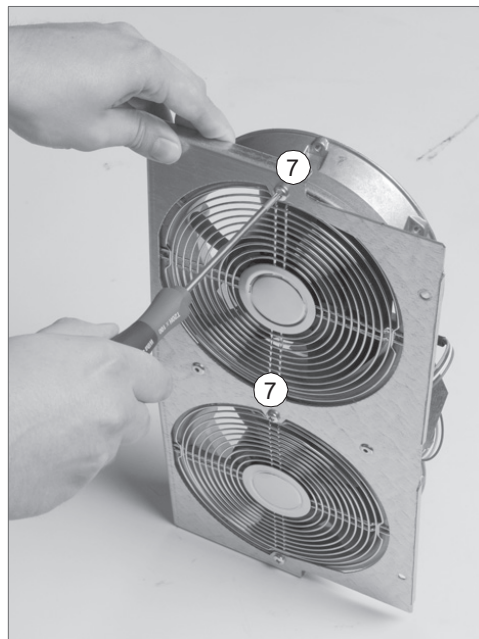
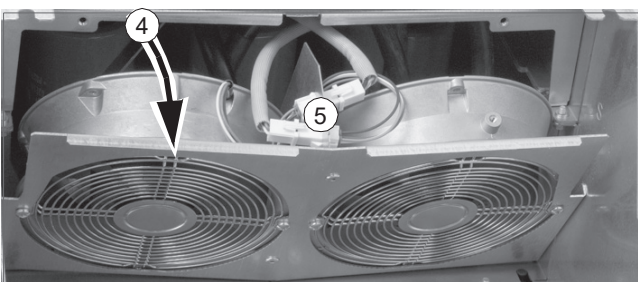
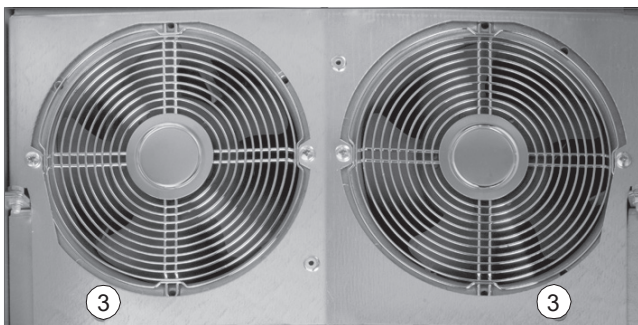

■ Replacing the drive module main fans (frames R10 and R11)



WARNING!

Obey the safety instructions of the drive. If you ignore them, injury or death, or damage to the equipment can occur.

1. Stop the drive and do the steps in section *Electrical safety precautions (page 18)* before you start the work.
2. Remove the drive module out of the cabinet as described in section *Replacing the drive module (frames R10 and R11) on page x*.
3. Open the support legs of the pedestal.
4. Undo the two screws that fasten the fan assembly plate.
5. Tilt the fan assembly plate down.
6. Disconnect the power supply wires of the fans.
7. Remove the fan assembly from the drive module.
8. Undo the fastening screws of the fan(s) and remove the fan(s) from the assembly plate.
9. Install the new fan(s) in reverse order.
10. Reset the counter (if used) in group 5 in the primary control program.

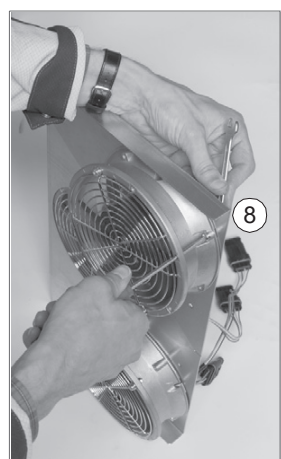

■ Replacing the circuit board compartment cooling fan (frames R10 and R11)



WARNING!

Obey the safety instructions of the drive. If you ignore them, injury or death, or damage to the equipment can occur.

1. Stop the drive and do the steps in section *Electrical safety precautions (page 18)* before you start the work.
2. Remove the drive module out of the cabinet as described in section *Replacing the drive module (frames R10 and R11) on page x*.
3. Undo the fastening screw of the fan enclosure.
4. Unplug the power supply cable of the fan.
5. Install the new fan in reverse order.
6. Reset the counter (if used) in group 5 in the primary control program.

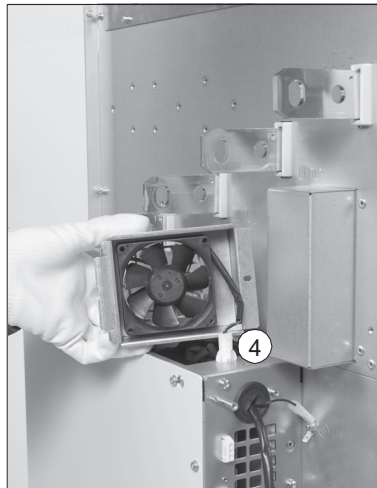

■ Replacing the IP54 (UL type 12) roof fan of frames R6 to R8



WARNING!

Obey the safety instructions of the drive. If you ignore them, injury or death, or damage to the equipment can occur.

1. Stop the drive and do the steps in section *Electrical safety precautions (page 18)* before you start the work.
2. Lift the front grating upwards and remove it.
3. Loosen the fastening screws of the front plate. Remove the plate.
4. Disconnect the fan supply wires.
5. Loosen the mounting screws of the fan.
6. Pull the fan out.
7. Install the new fan in reverse order.

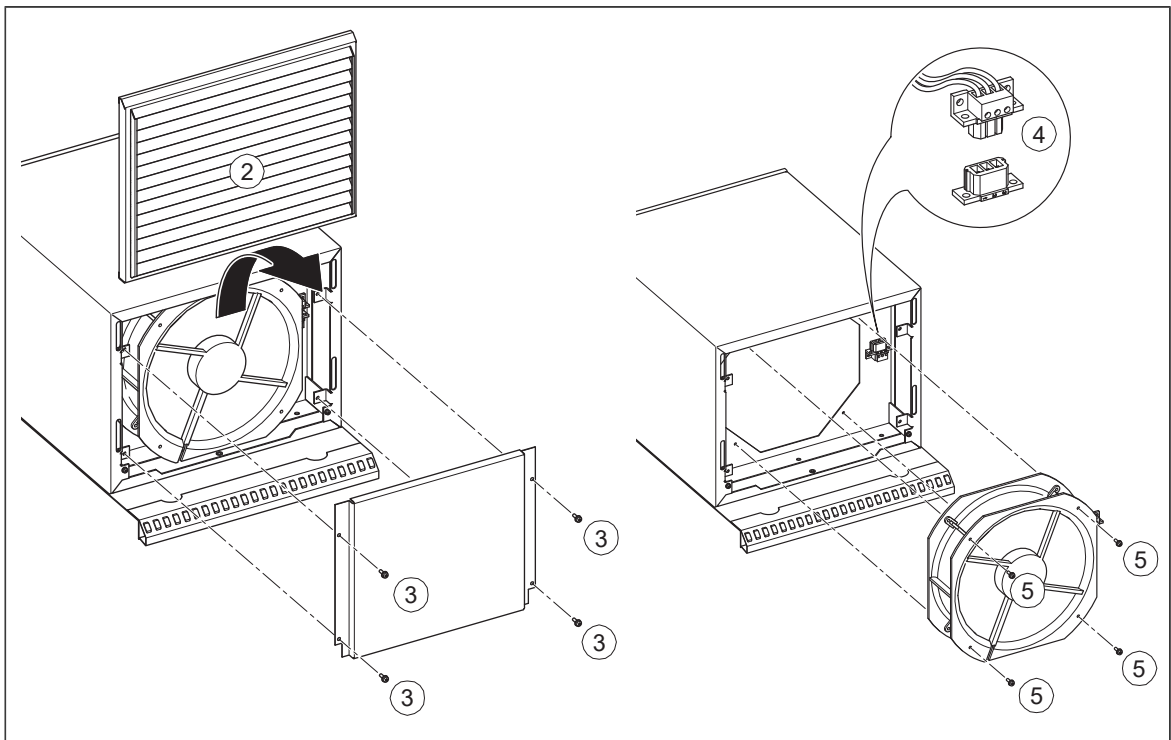

■ Replacing the IP54 (UL type 12) roof fan of frame R9



WARNING!

Obey the safety instructions of the drive. If you ignore them, injury or death, or damage to the equipment can occur.

1. Stop the drive and do the steps in section *Electrical safety precautions (page 18)* before you start the work.
2. Lift the front and back gratings upwards and remove them.
3. Loosen the mounting screws of the fan cover.
4. Lift the cover off.
5. Disconnect the fan supply wires.
6. Loosen the mounting screws of the fan.
7. Lift the fan off.
8. Install the new fan in reverse order.

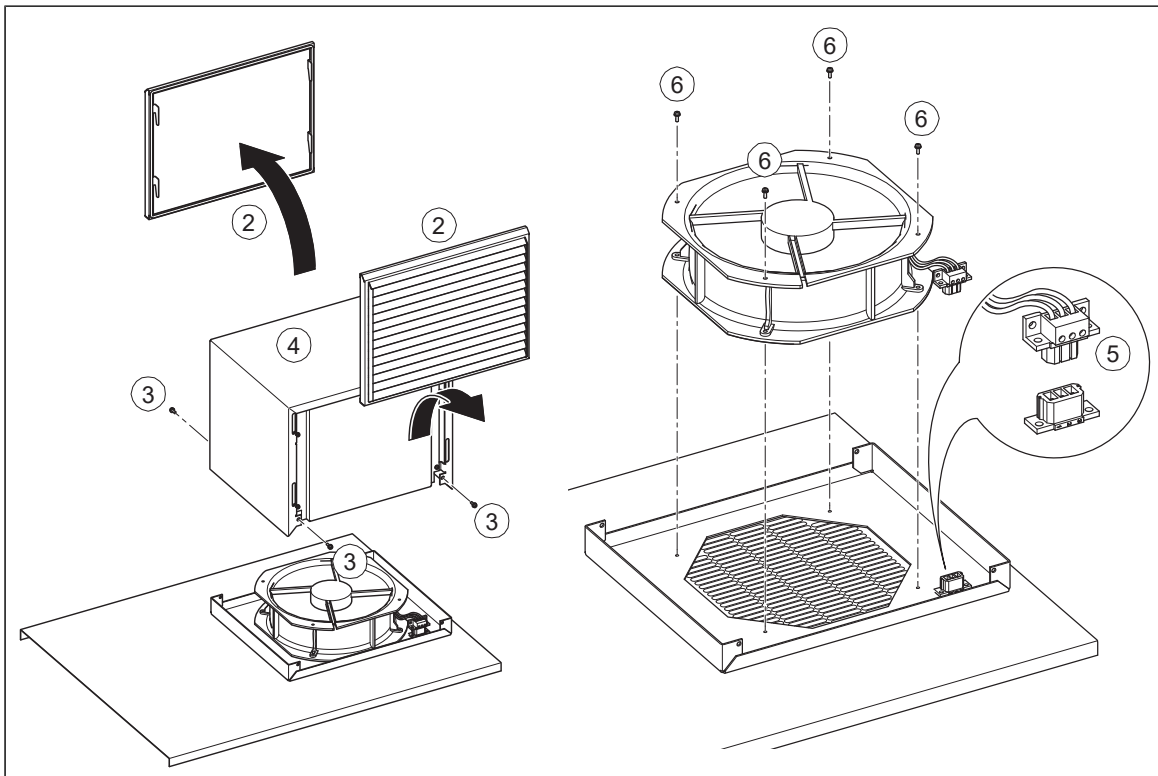

■ Replacing the IP54 (UL type 12) roof fan of frames R10 and R11



WARNING!

Obey the safety instructions of the drive. If you ignore them, injury or death, or damage to the equipment can occur.

1. Stop the drive and do the steps in section *Electrical safety precautions (page 18)* before you start the work.
2. Slide the front and back gratings upwards and remove them.
3. Remove the mounting screws of the upper cover and lift the cover off.
4. Disconnect the fan power supply wires.
5. Remove the mounting screws of the fan.
6. Remove the mounting screws of the fan cover.
7. Lift the fan off.
8. Install the new fan in reverse order.

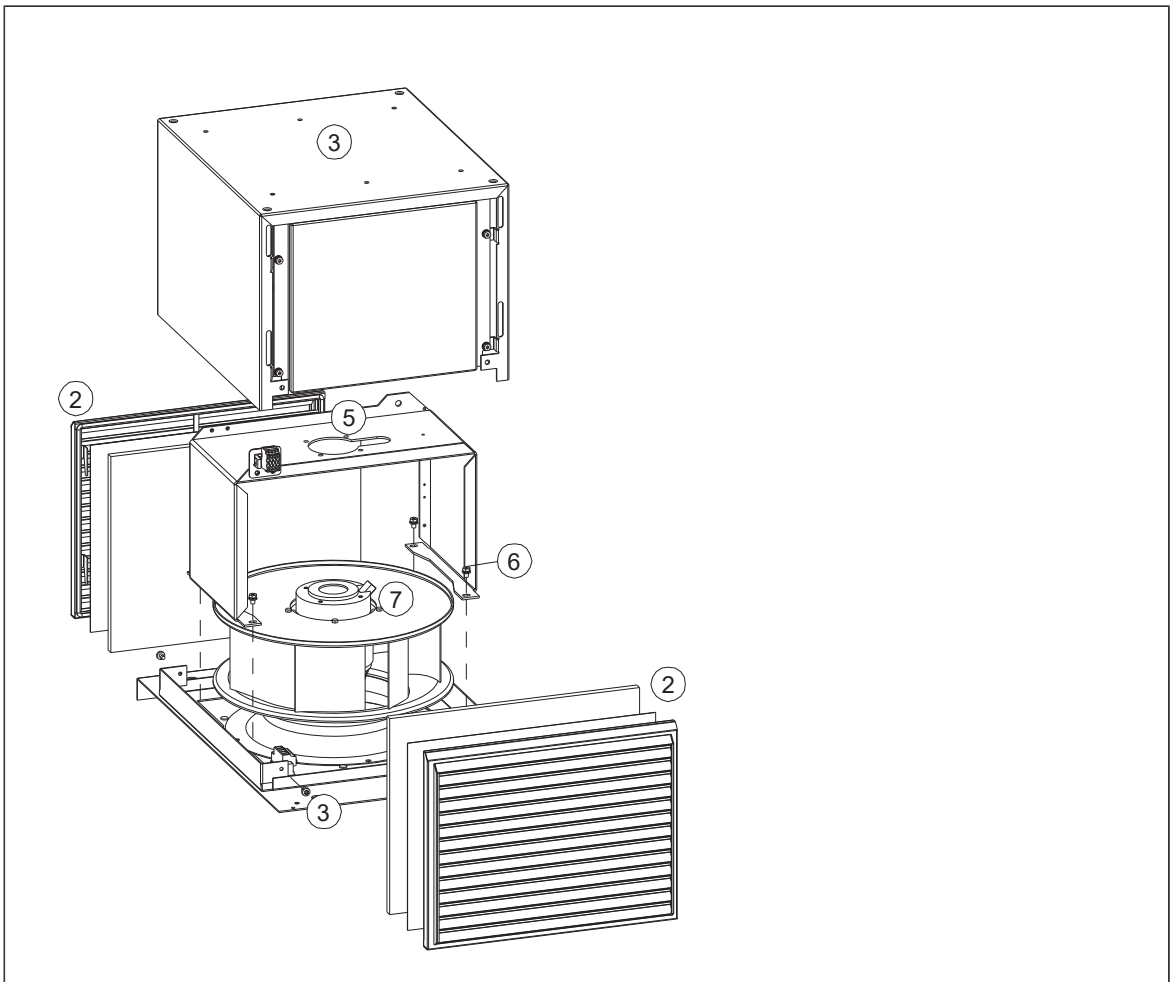

■ Replacing the NSIN sine filter cooling fan

For replacing the NSIN sine filter cooling fan, see *Sine filters hardware manual* (3AXD50000016814 [English]).

Replacing the drive module (frames R6 to R8)

Required in this replacing procedure: preferably two persons, lifting chains, lifting device, a set of screw drivers and torque wrench with extension bar. A lifting device is available from ABB. For its installation and use, see *Converter module lifting device for drive cabinets hardware manual* ([3AXD50000210268](#) [English]).



WARNING!

Obey the safety instructions of the drive. If you ignore them, injury or death, or damage to the equipment can occur.



WARNING!

Make sure that the cabinet is secured to the floor. If not, the cabinet can topple over when the heavy drive module is slid forward in front of the cabinet. This can cause injury or death, and damage to the equipment.

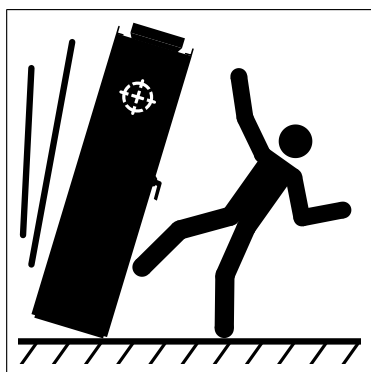

-
1. Stop the drive and do the steps in section *Electrical safety precautions (page 18)* before you start the work.
 2. For drives with options +L505 and +L506: Remove the shroud.
 3. For drives with options +L505 and +L506: Remove the Pt100 and thermistor relay mounting plate by loosening the two mounting screws and lifting the mounting plate up.
 4. Remove the drive module main fan (see page [168](#)).
 5. Undo the screws on the right-hand side of the swing-out frame.
 6. Undo the hinge screw at the top and bottom of the swing-out frame to enable the frame to open aside far enough.
 7. Unplug the control wire terminals at the right-hand side of the cabinet.
 8. See the warning below. Remove the mounting plate above the “door” fan by loosening the mounting screws and lifting the plate up.
-



WARNING!

For drives with options +G300, +G301, +G307 and +G313: Before you remove the mounting plate, disconnect the external power sources that supply the options. Unplug the control cable terminals at the back side of the mounting plate.

9. Unplug the control cable terminals from the control unit. Disconnect the control cables from the option modules on the control unit.
-

10. For drives with additional terminal block (option +L504): Disconnect the control cables from terminal block X504 and remove the terminal block by loosening the mounting screws and lifting it forwards.
 11. Disconnect the input and motor cabling busbars from the drive module terminals.
 12. Drives with option +D150 or +D151: Disconnect the resistor busbars from the drive module terminals.
 13. Drives with option +H356: Disconnect the DC busbars from the drive module terminals.
 14. Unplug the cabinet fan power supply cables and remove the fan assembly above the drive module.
 15. Remove the slide extension rails from the left-hand side of the cabinet by undoing the mounting screws.
 16. Install the extension rails at the end of the sliding bars.
 17. Undo the upper mounting nuts of the drive module.
 18. Undo the lower mounting nuts of the drive module.
 19. Slide the drive module towards the end of the sliding bars.
 20. Secure the drive module with chains from the lifting eyes.
 21. Lift the module out of the cabinet with the lifting device.
 22. Install the new module in reverse order.
-

R6 to R8

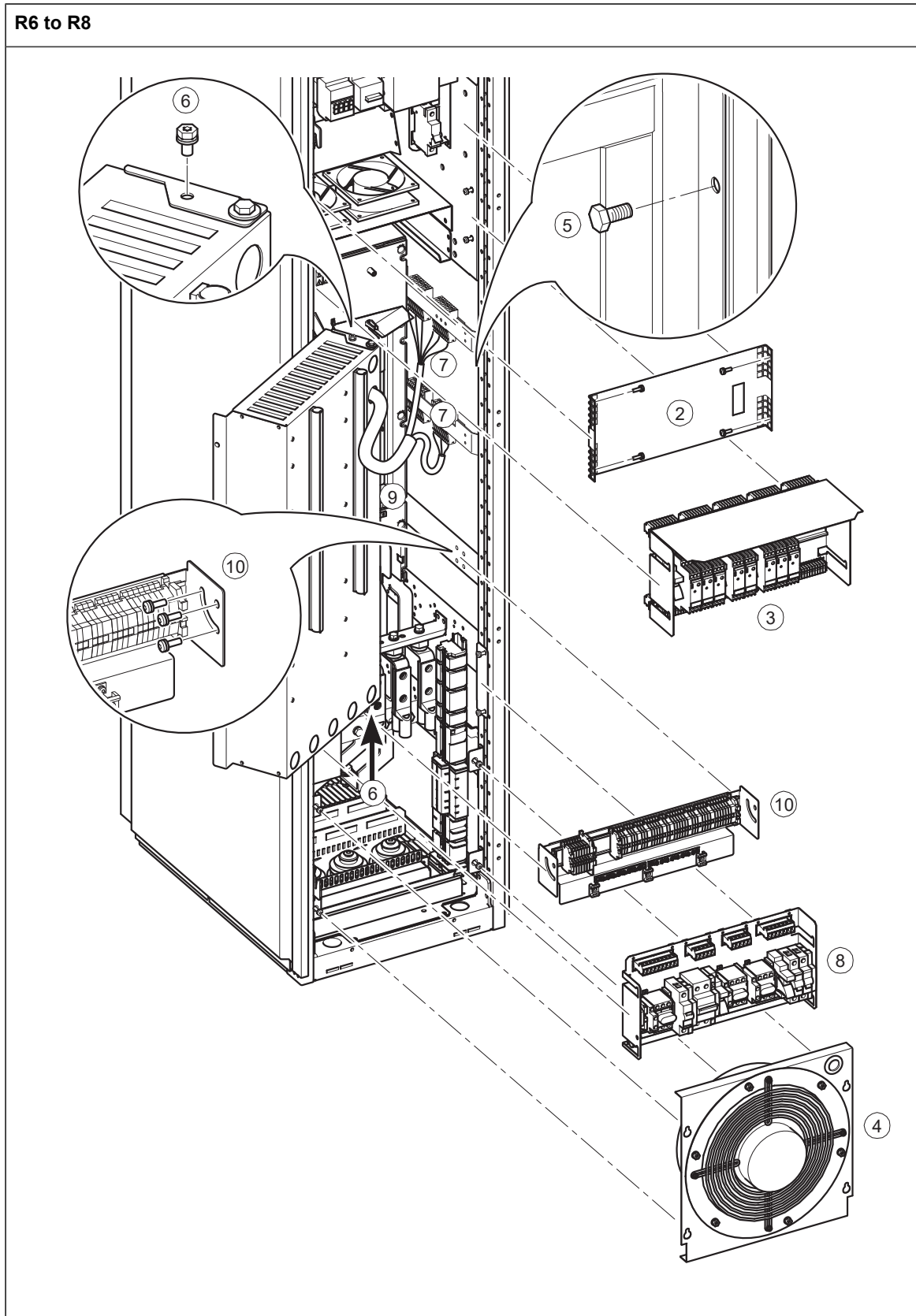

R6 to R8

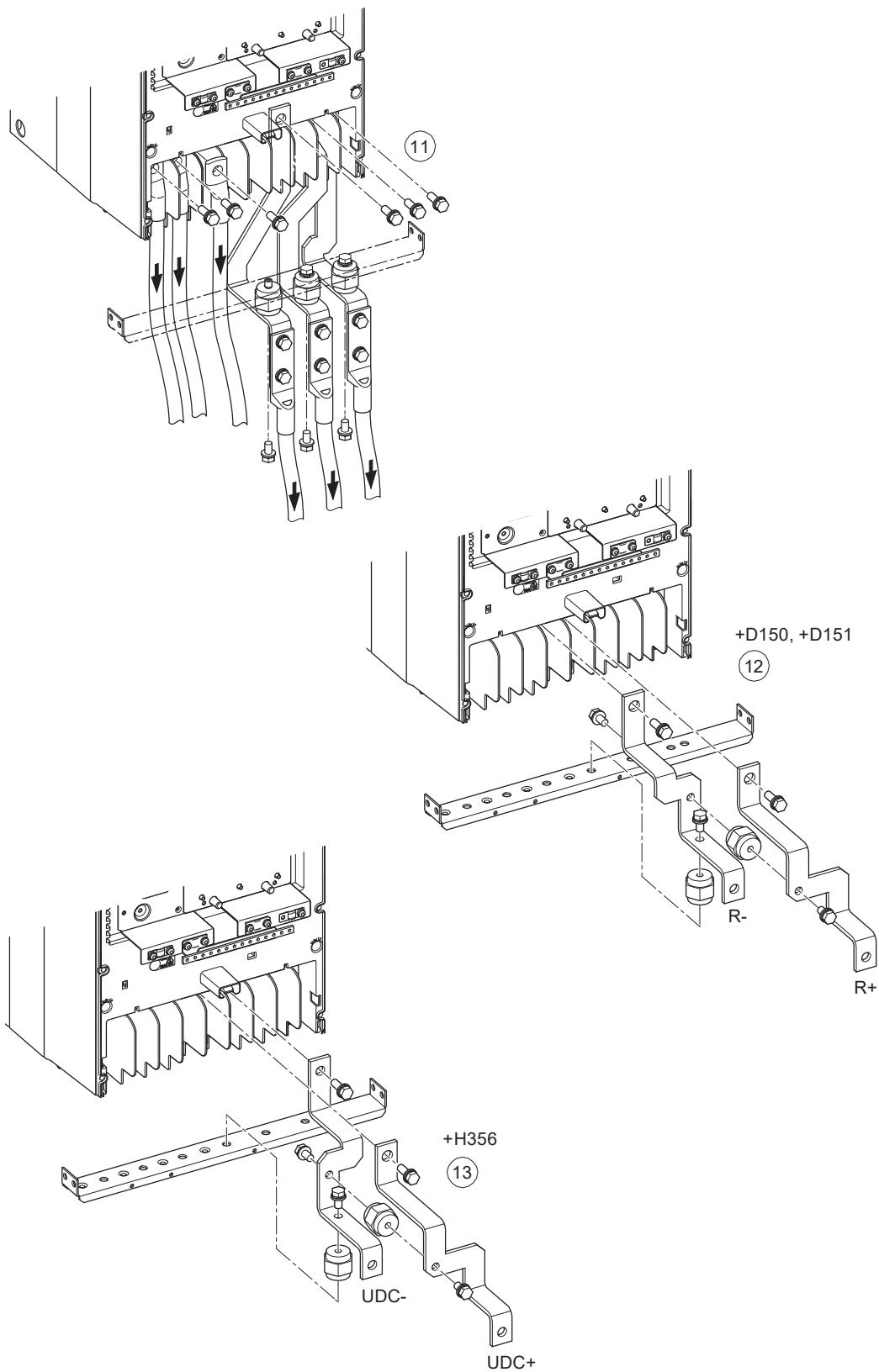

R6 to R8

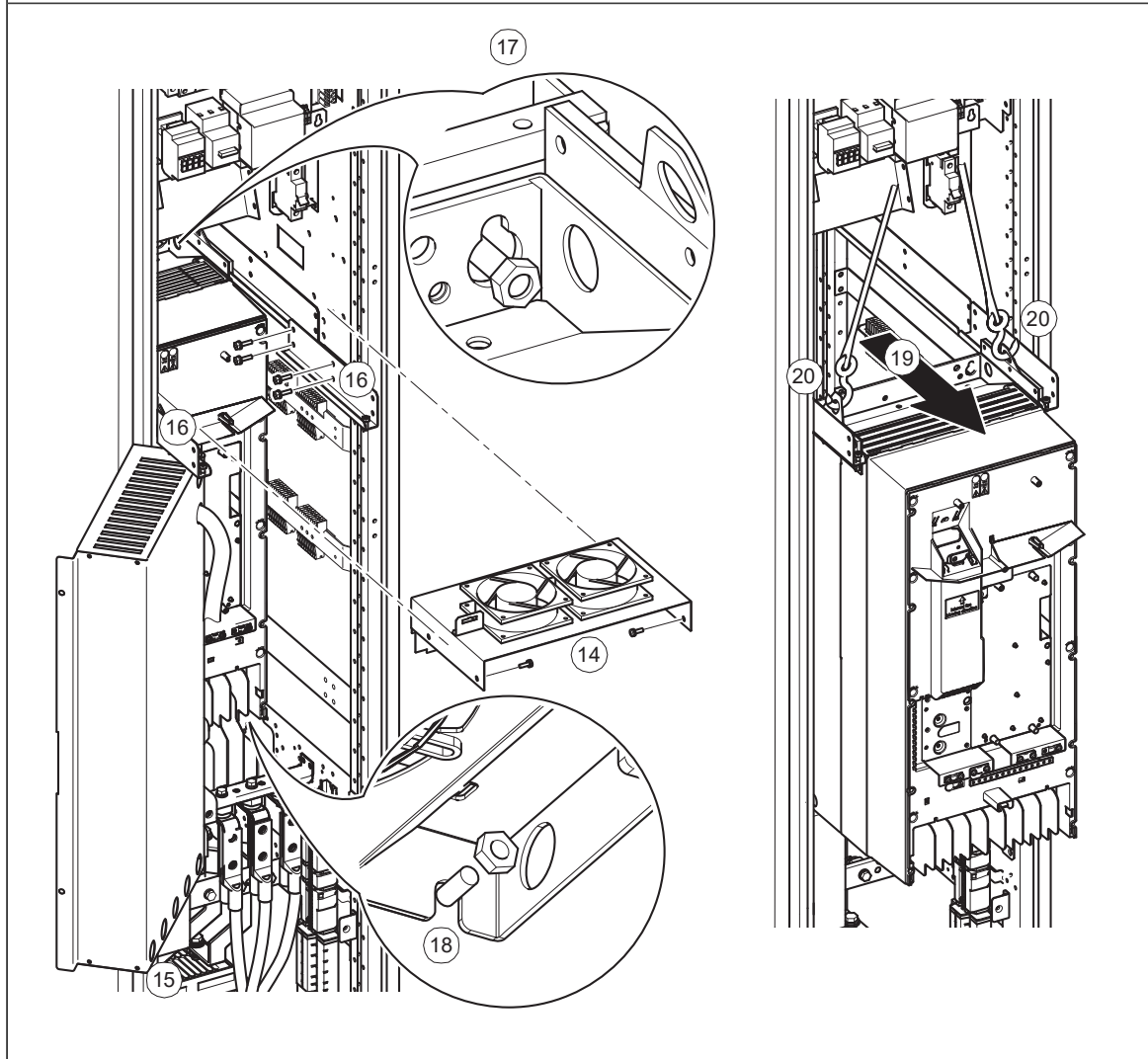

Replacing the drive module (frame R9)

Required in this replacing procedure: preferably two persons, lifting chains, lifting device, a set of screw drivers and torque wrench with extension bar. A lifting device is available from ABB. For its installation and use, see *Converter module lifting device for drive cabinets hardware manual* ([3AXD50000210268](#) [English]).



WARNING!

Obey the safety instructions of the drive. If you ignore them, injury or death, or damage to the equipment can occur.



WARNING!

Make sure that the cabinet is secured to the floor. If not, the cabinet can topple over when the heavy drive module is slid forward in front of the cabinet. This can cause physical injury or death and damage to the equipment.

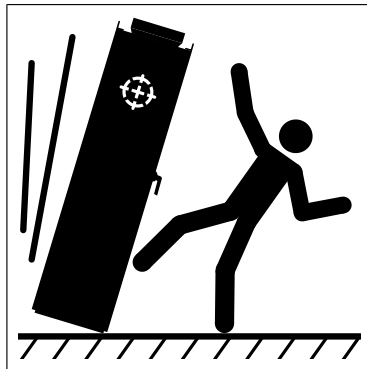

-
1. Stop the drive and do the steps in section *Electrical safety precautions (page 18)* before you start the work.
 2. Remove the shroud.
 3. See the warning below. Remove the mounting plate above the shroud by loosening the mounting screws and lifting the plate up.



WARNING!

For drives with options +G300, +G301, +G307 and +G313: Before you remove the mounting plate, disconnect the external power sources supplying the options. Unplug the control cable terminals at the back side of the mounting plate.

4. For drives with options +L505 and +L506: Remove the Pt100 and thermistor relay mounting plate by loosening the two mounting screws and lifting the mounting plate up.
 5. For drives with additional terminal block (option +L504): Disconnect the control cables from terminal block X504. Loosen the mounting screws of the terminal block and remove it.
 6. Loosen the screws on the right-hand side of the swing-out frame and open the swing-out frame.
 7. Unplug the control wire terminals at the right-hand side of the cabinet.
 8. Unplug the control cable terminals from the control unit. Disconnect the control cables from the option modules on the control unit.
-

9. Unplug the cabinet fan power supply cables and remove the fan assembly above the drive module.
 10. Unplug the wire terminals and remove the mounting plate.
 11. Disconnect the power cabling busbars from the drive module terminals.
 12. Remove the slide extension rails (attached to the slide rails) by undoing the mounting screws. Install the extension rails at the end of the sliding rails.
 13. Undo the upper mounting nuts of the drive module.
 14. Undo the lower mounting nuts of the drive module.
 15. Remove the two mounting screws of the top right mounting plate. Turn the plate to the horizontal position.
 16. Slide the drive module towards the end of the sliding bars.
 17. Secure the drive module with chains from the lifting eyes.
 18. Lift the module out of the cabinet with the lifting device.
 19. Install the new module in reverse order. Undo the hinge screw at the top and bottom of the swing-out frame to enable the frame to open as far enough.
-

R9

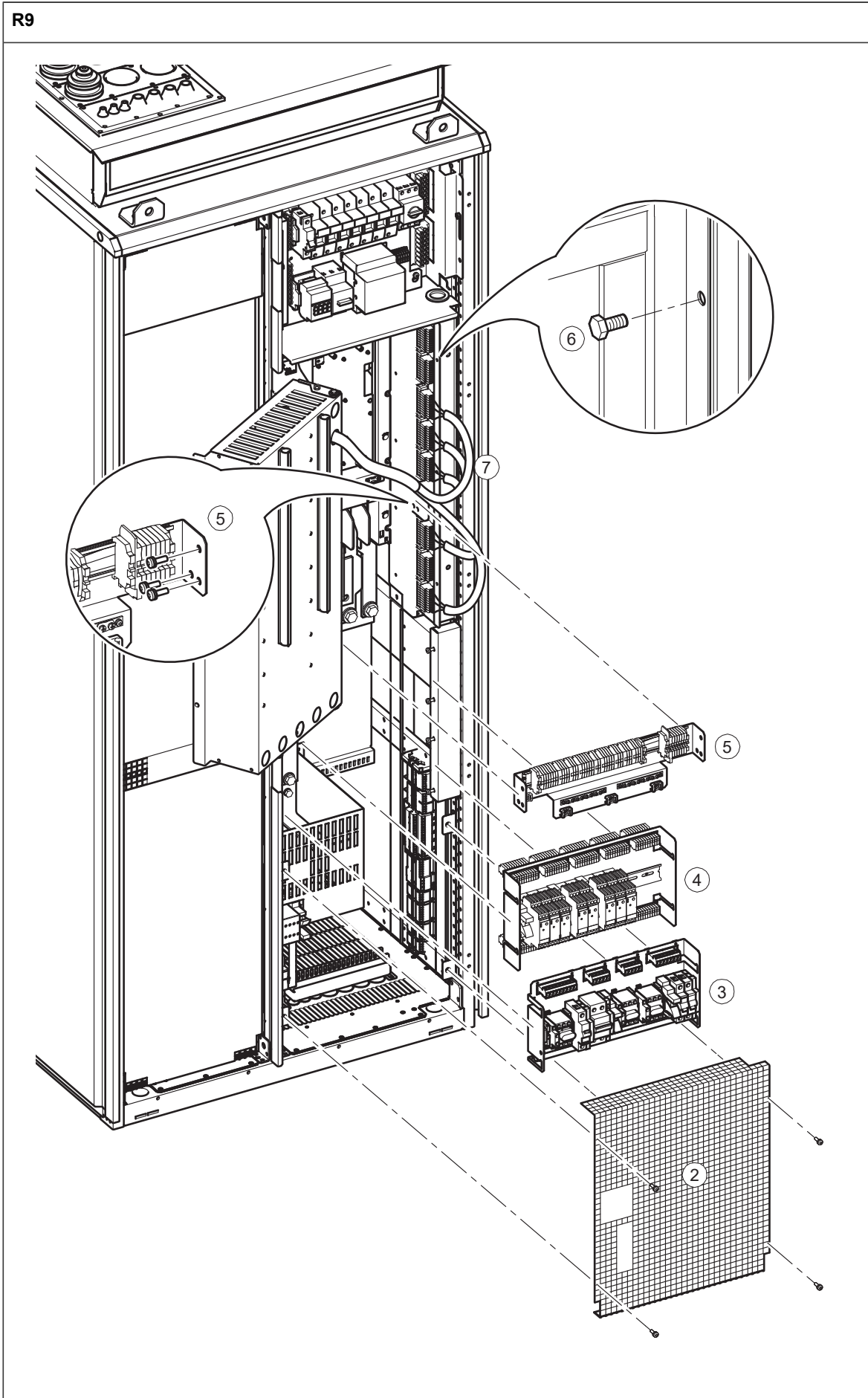

R9

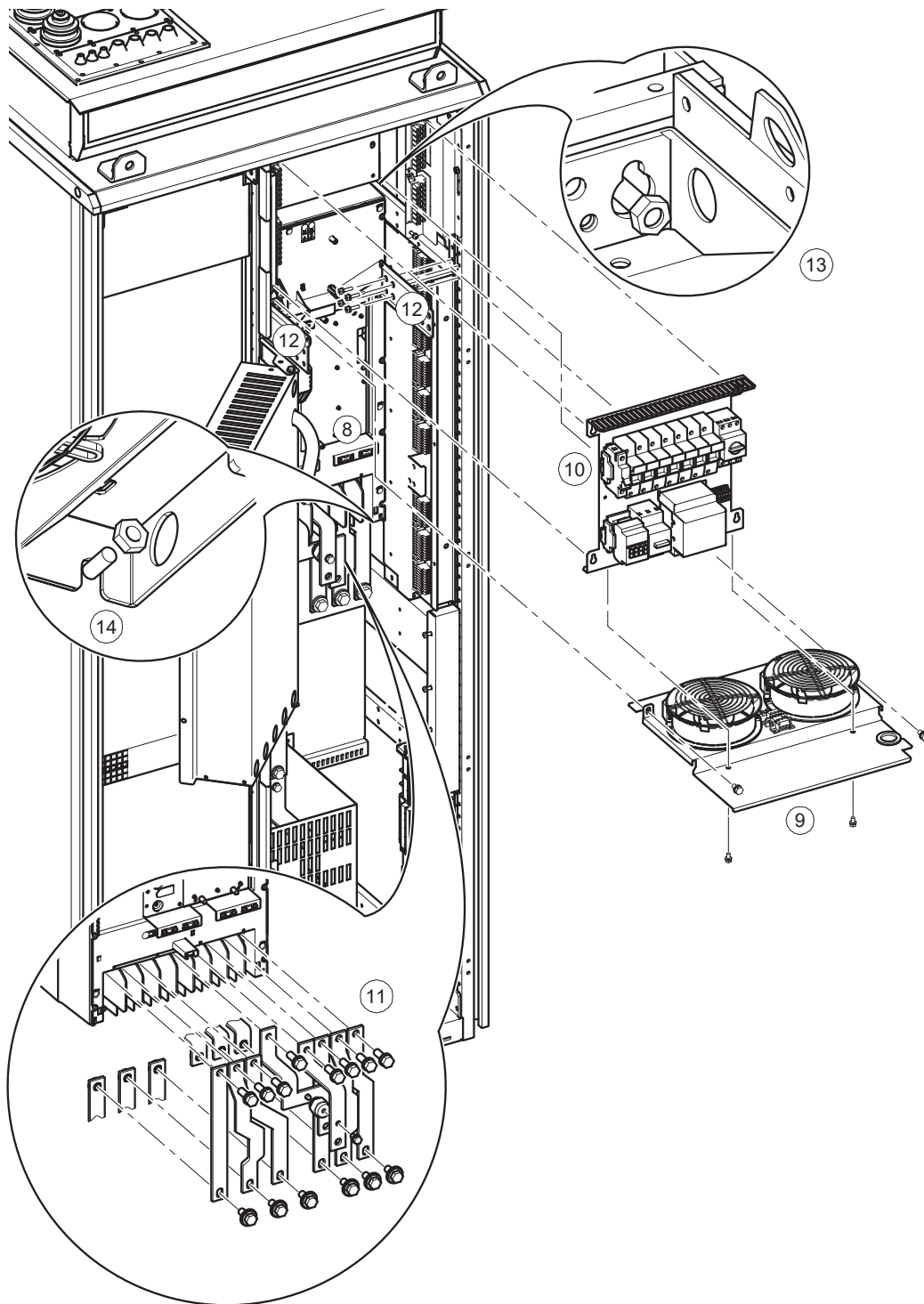

R9

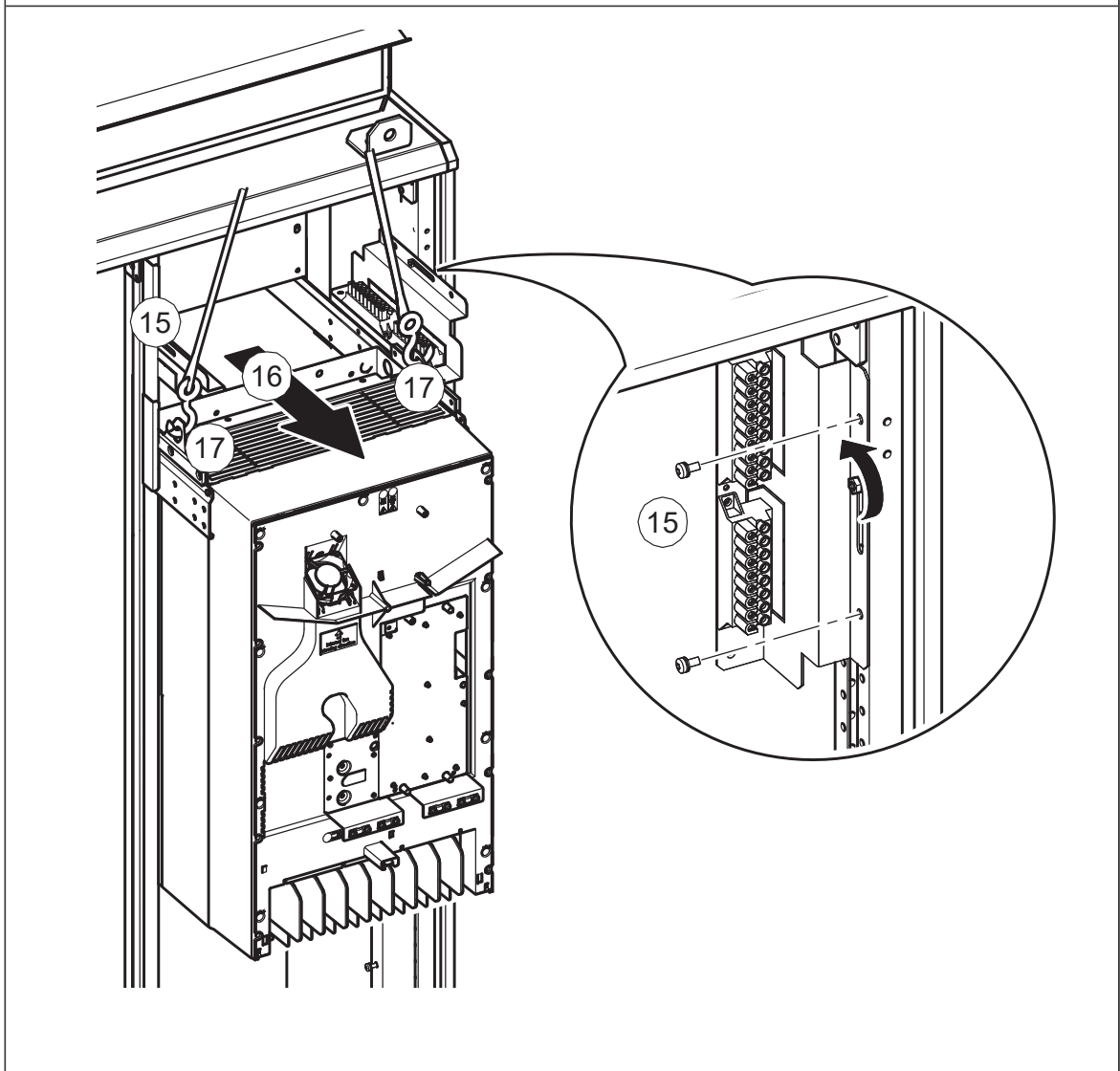

Replacing the drive module (frames R10 and R11)

This replacing procedure requires: preferably two persons, installation ramp, a set of screw drivers and a torque wrench with an extension bar.

The drawings show frame R11. The details in frame R10 are slightly different.



WARNING!

- Do not use the module extraction/installation ramp with plinth heights which exceeds the maximum allowed height. See the technical data.
- Attach the module extraction/installation ramp carefully.
- Make sure that the module does not topple over when you move it on the floor: To open the support legs, press each leg a little down and turn it aside (1, 2). Whenever possible attach the module also with chains. Do not tilt the drive module. It is heavy and its center of gravity is high. The module overturns from a sideways tilt of 5 degrees. Do not leave the module unattended on a sloping floor.

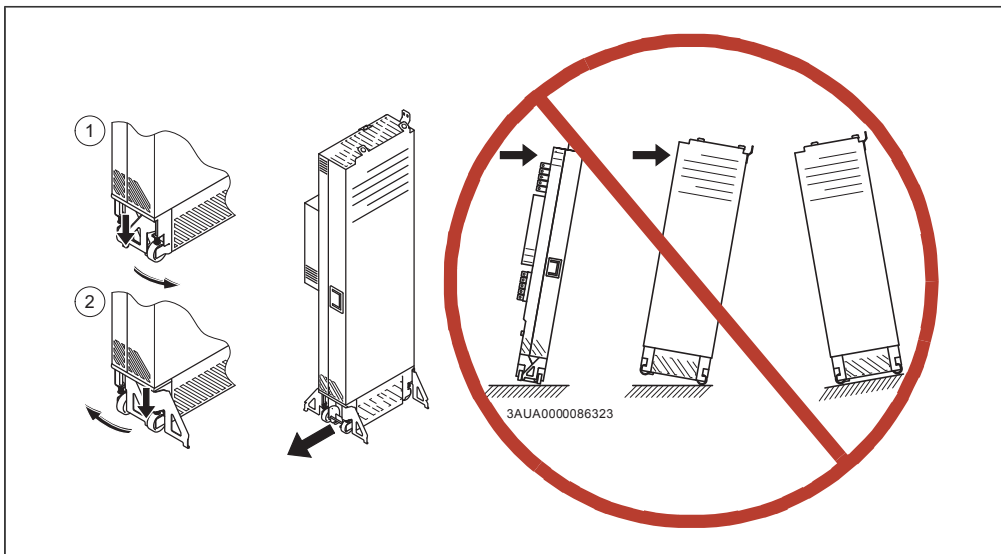

- To prevent the drive module from falling, attach its top lifting lugs with chains to the cabinet (1) before you push the module into the cabinet and pull it from the cabinet. Push the module into the cabinet and pull it from the cabinet carefully preferably with help from another person. Keep a constant pressure with one foot on the base of the module (2) to prevent the module from falling on its back.

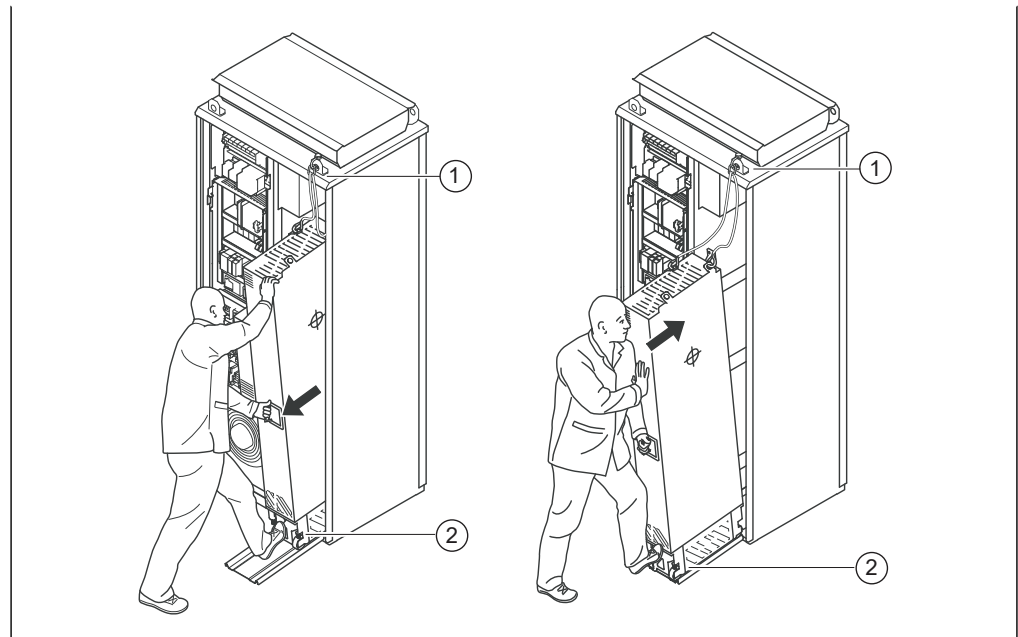

1. Stop the drive and do the steps in section [Electrical safety precautions \(page 18\)](#) before you start the work.
2. Unplug quick connector(s) at the right top corner of the control unit mounting plate.
3. Remove the control unit mounting plate.
4. Remove the shroud.
5. Remove the air baffle.
6. Disconnect the drive module input busbars. Combi screw M12, 70 N·m (52 lbf·ft).
7. Disconnect the drive module output busbars. Combi screw M12, 70 N·m (52 lbf·ft).
8. Undo the screws that fasten the drive module to the cabinet at the top and behind the front support legs.
9. Attach the extraction ramp to the cabinet base with two screws.
10. Attach the drive module lifting lugs to the cabinet lifting lug with chains.
11. Pull the drive module carefully out of the cabinet preferably with help from another person.
12. Install the new module in reverse order.

R10 and R11

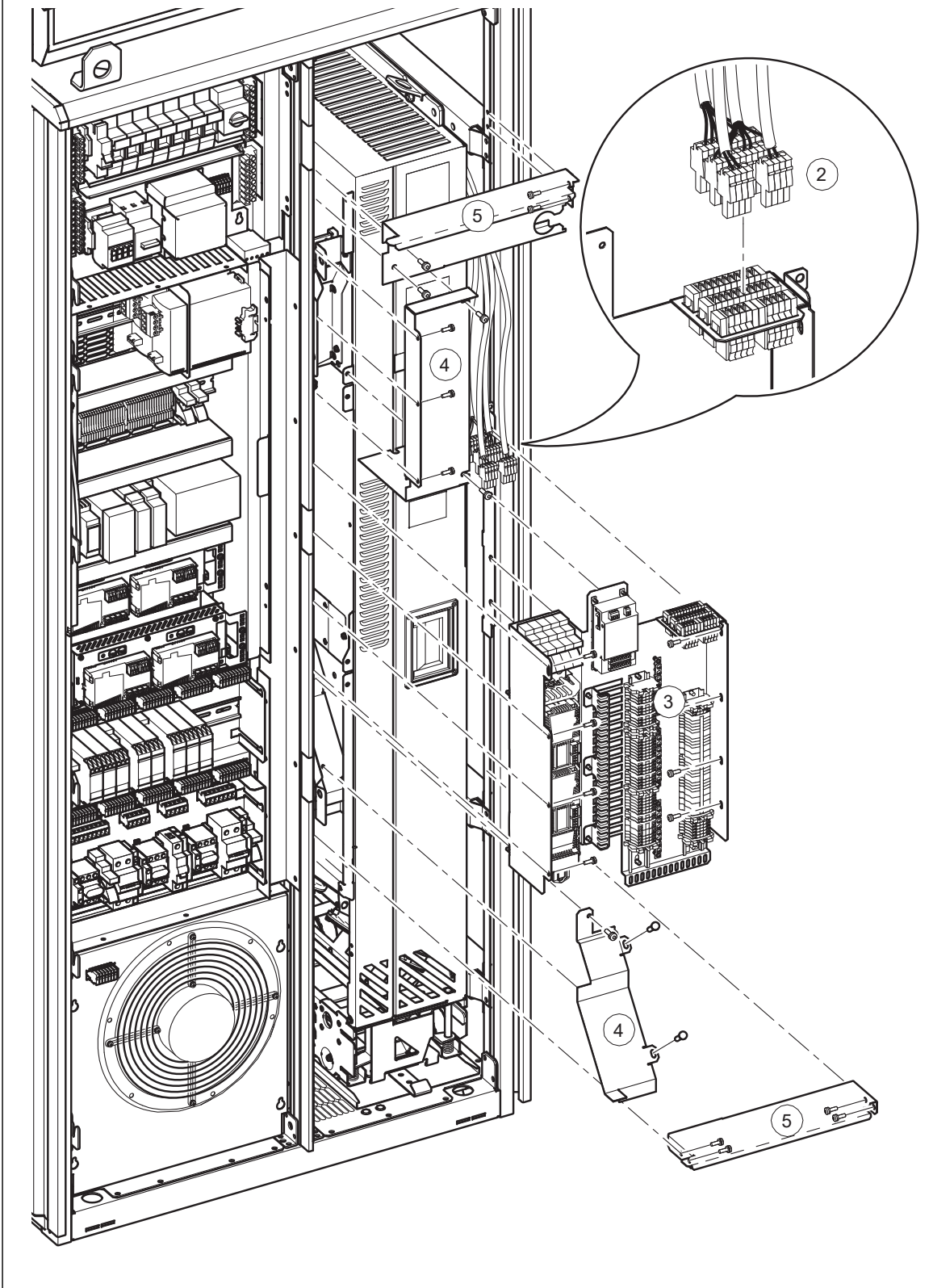

R10 and R11

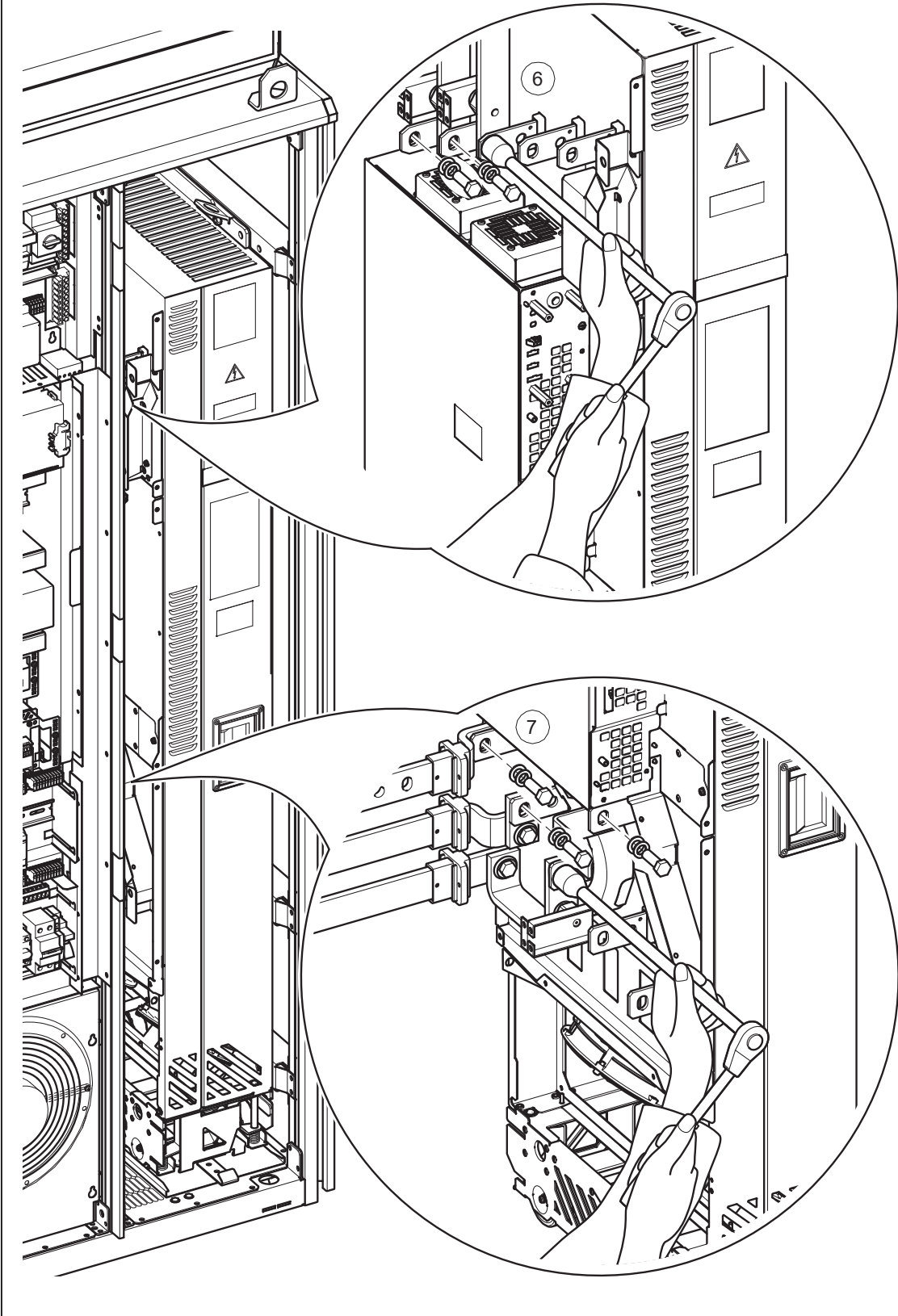

R10 and R11

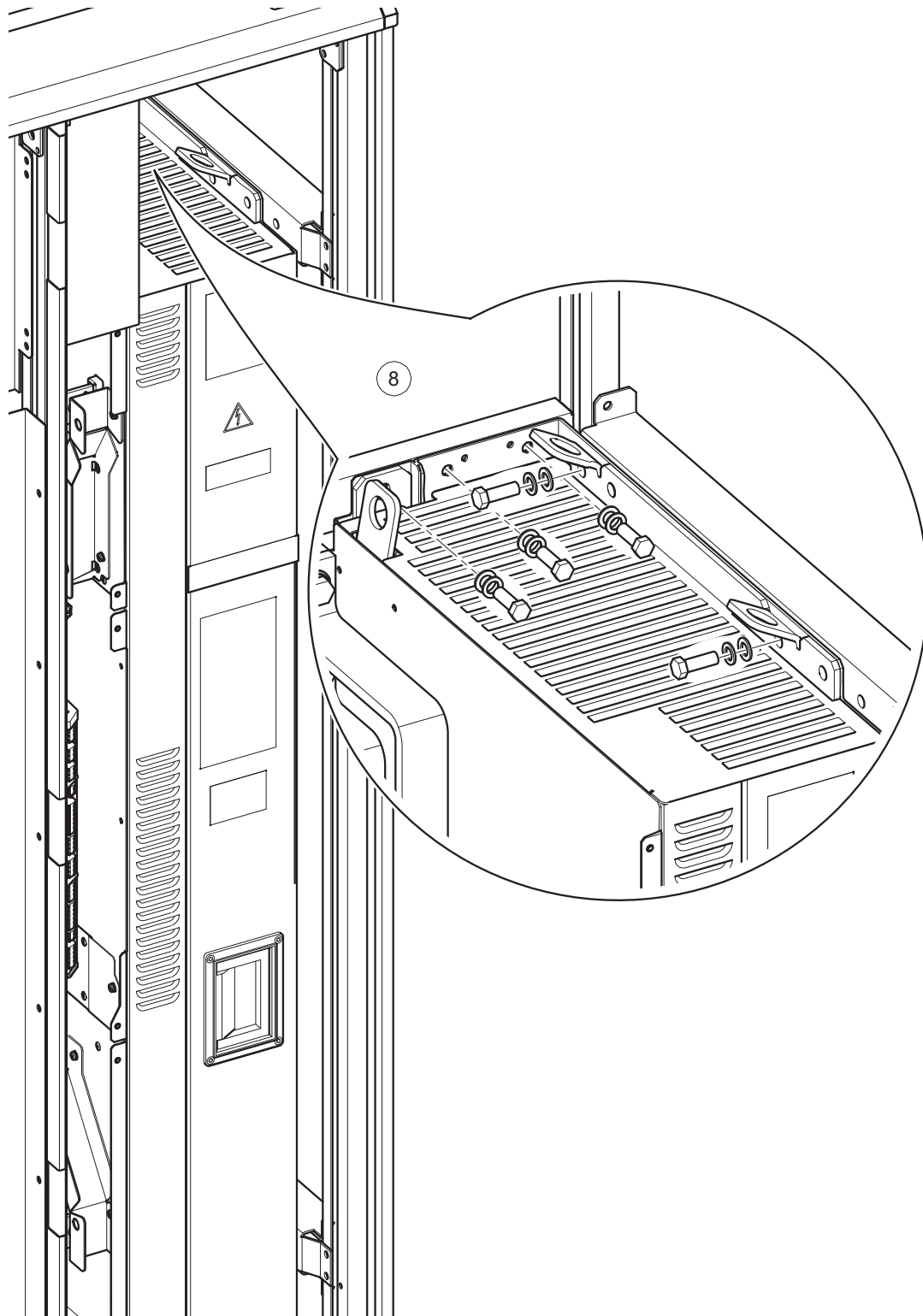

R10 and R11

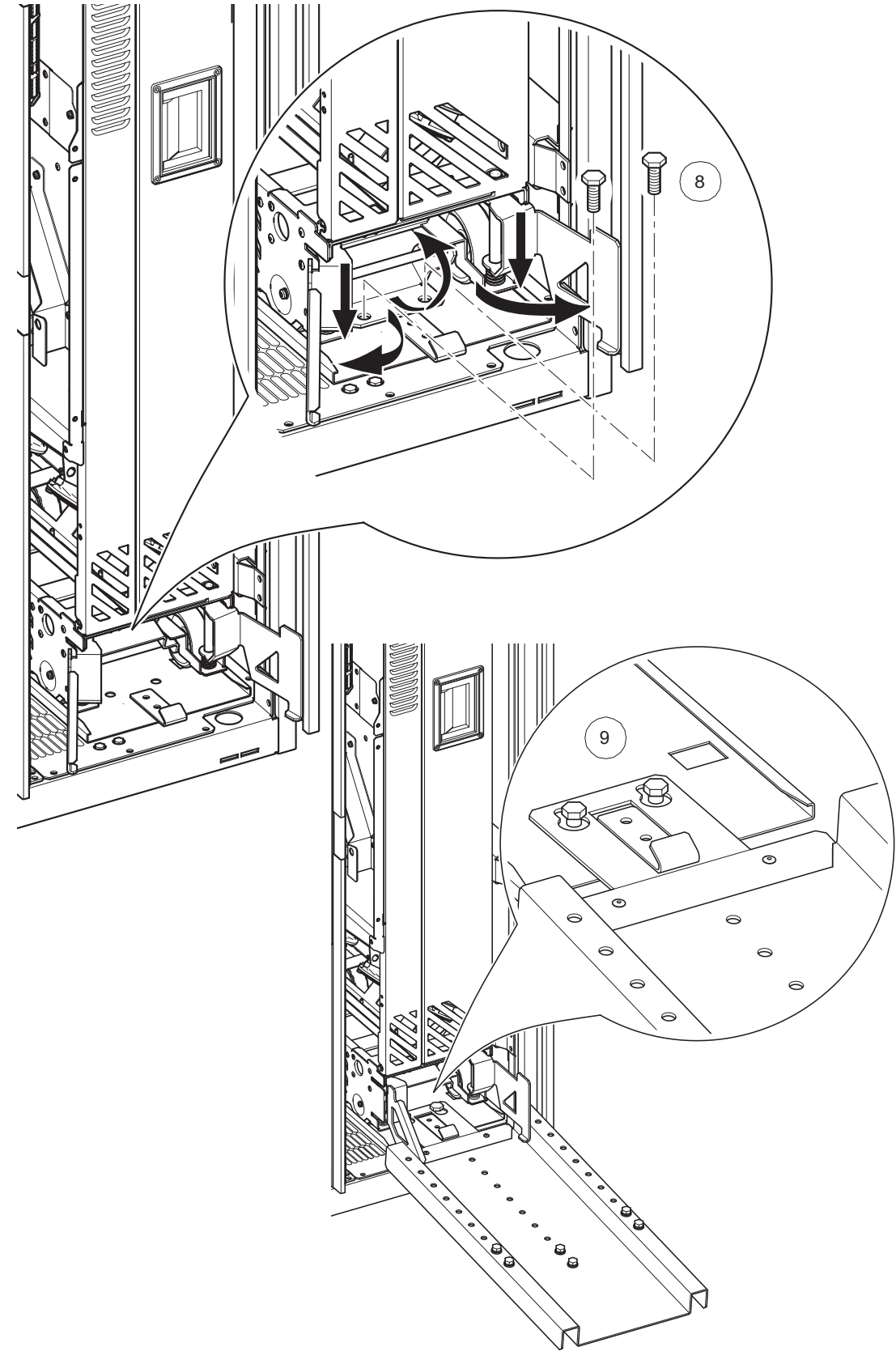

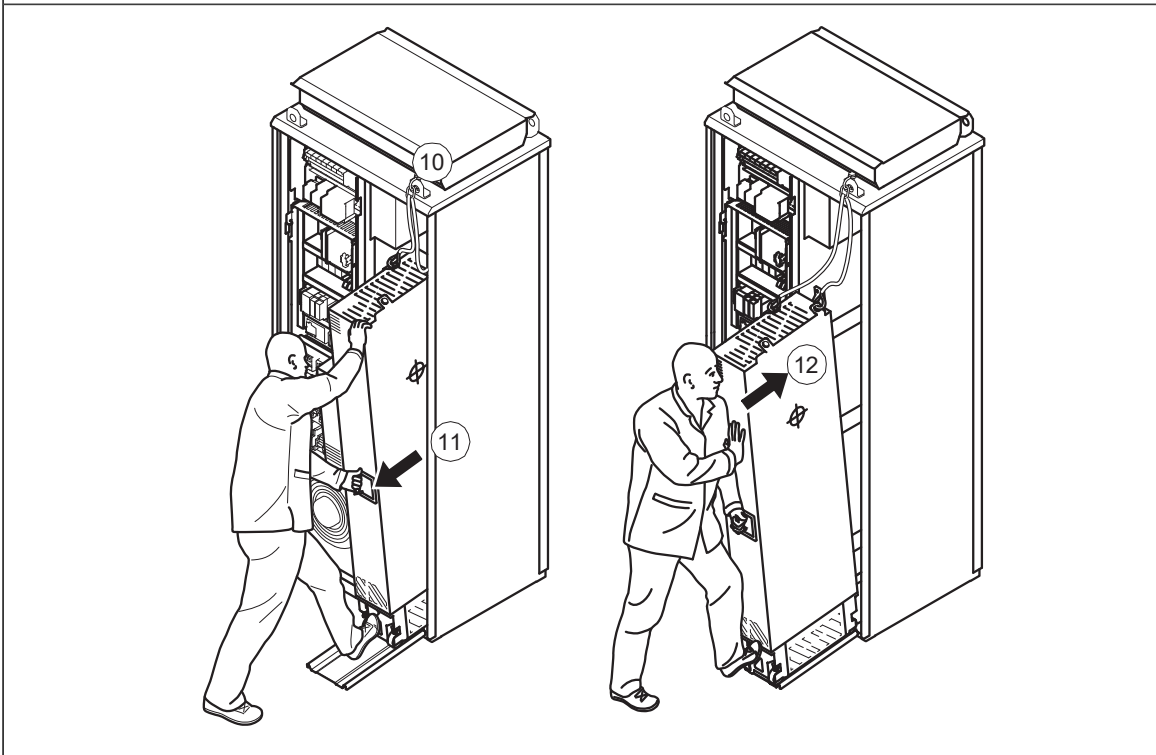
R10 and R11

Capacitors

The DC link of the drive contains several electrolytic capacitors. Operating time, load, and surrounding air temperature have an effect on the life of the capacitors. Capacitor life can be extended by decreasing the surrounding air temperature.

Capacitor failure is usually followed by damage to the unit and an input cable fuse failure, or a fault trip. If you think that any capacitors in the drive have failed, contact ABB.

■ Reforming the capacitors

The capacitors must be reformed if the drive has not been powered (either in storage or unused) for a year or more. The manufacturing date is on the type designation label. For information on reforming the capacitors, see *Capacitor reforming instructions* ([3BFE64059629](https://library.abb.com/en) [English]) in the ABB Library (<https://library.abb.com/en>).

Control panel

For detailed information on the control panel, see *ACx-AP-x assistant control panels user's manual* ([3AUA0000085685](https://library.abb.com/en) [English]).

■ Cleaning the control panel

Use a soft damp cloth to clean the control panel. Avoid harsh cleaners which could scratch the display window.

■ Replacing the battery

The instructions below describe how to replace the battery that powers the real-time clock of the control panel.

1. Turn the lid on the back of the control panel counter-clockwise until the lid opens.
2. Remove the battery gently.
3. Replace the battery with a new CR2032 battery. The battery holder has grip nails.
First slide the battery and then press on the other side. The battery will snap in.
4. Make sure that the battery polarity shows positive on the upside.
5. Put the lid back and tighten it by turning it clockwise.
6. Dispose of the old battery according to local disposal rules or applicable laws.



ZCU-12 control unit

■ Replacing the memory unit of ZCU-12

After replacing a control unit, you can retain the existing parameter settings by transferring the memory unit from the defective control unit to the new control unit. After power-up, the drive will scan the memory unit. This can take several minutes.



WARNING!

Do not remove or insert the memory unit when the control unit is powered.

1. Stop the drive and do the steps in section *Electrical safety precautions (page 18)* before you start the work.
2. Pull the clip at the side of the memory up.

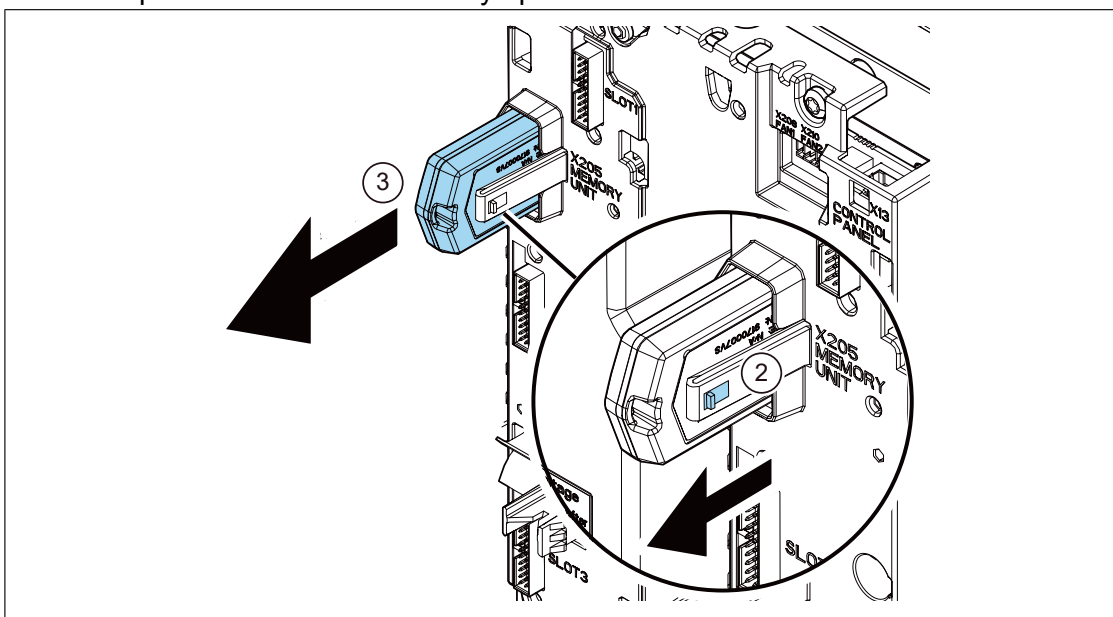

3. Take the unit off.
4. Replace the unit in reverse order.

■ Replacing the ZCU-12 control unit battery

The control unit battery is of type CR2032. For instructions on how to replace the control unit battery, contact an authorized ABB service center.

ZCU-14 control unit

■ Replacing the memory unit of ZCU-14

After replacing a control unit, you can retain the existing parameter settings by transferring the memory unit from the defective control unit to the new control unit. After power-up, the drive will scan the memory unit. This can take several minutes.



WARNING!

Do not remove or insert the memory unit when the control unit is powered.



WARNING!

Obey the safety instructions of the drive. If you ignore them, injury or death, or damage to the equipment can occur.

1. Stop the drive and do the steps in section [Electrical safety precautions \(page 18\)](#) before you start the work.
2. Pull the clip of the memory forward.

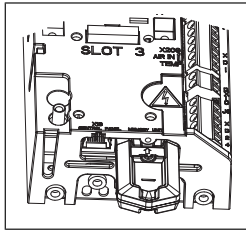

3. Take the unit off.
4. Replace the unit in reverse order.

■ Replacing the ZCU-14 control unit battery



WARNING!

Obey the safety instructions of the drive. If you ignore them, injury or death, or damage to the equipment can occur. If you are not a qualified electrical professional, do not do installation or maintenance work.

1. Stop the drive and do the steps in section [Electrical safety precautions \(page 18\)](#) before you start the work.
2. Remove the M4×8 (T20) screws at the ends of the control unit.
3. To see the battery, remove the XD2D terminal block.
4. Carefully lift the edge of the control unit cover on the side with the I/O terminal blocks.
5. Carefully pull the battery out of the battery holder.
6. Carefully put a new CR2032 battery into the battery holder.
7. Close the control unit cover.
8. Tighten the M4×8 (T20) screws.
9. Install the XD2D terminal block.

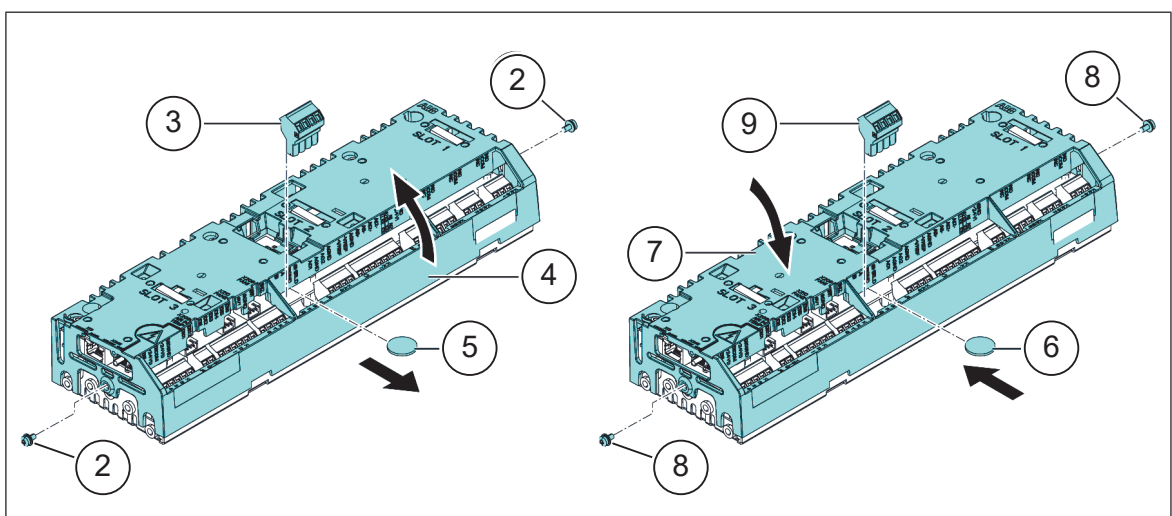

Replacing safety functions modules (FSO-12, option +Q973 and FSO-21, option +Q972)

Do not repair safety functions modules. Replace a faulty module with a new one as described in section *Installation of an FSO-xx safety functions module beside the ZCU-12 control unit (page 137)*.

12

Technical data

Contents of this chapter

This chapter contains the technical specifications of the drive, for example, the ratings, fuse data, sizes and technical requirements, provisions for fulfilling the requirements for CE and other markings.

Ratings

The nominal ratings for the drives with 50 Hz and 60 Hz supply are given below. The symbols are described below the table.

IEC Ratings											
ACS880-07-...	Frame size	Input rating	Output ratings								
			No-overload use				Light-overload use		Heavy-duty use		
			I_1	I_{max}	I_n	P_n	S_n	I_{Ld}	P_{Ld}	I_{Hd}	P_{Hd}
			A	A	A	kW	kVA	A	kW	A	kW
$U_n = 400\text{ V}$											
0105A-3	R6	105	148	105	55	73	100	55	87	45	
0145A-3	R6	145	178	145	75	100	138	75	105	55	
0169A-3	R7	169	247	169	90	117	161	90	145	75	
0206A-3	R7	206	287	206	110	143	196	110	169	90	
0246A-3	R8	246	350	246	132	170	234	132	206	110	
0293A-3	R8	293	418	293	160	203	278	160	246*	132	
0363A-3	R9	363	498	363	200	251	345	200	293	160	
0430A-3	R9	430 ¹⁾	545	430 ¹⁾	250	298	400	200	363**	200	
0505A-3	R10	505	560	505	250	350	485	250	361	200	

IEC Ratings										
ACS880-07-...	Frame size	Input rating	Output ratings							
			No-overload use				Light-overload use		Heavy-duty use	
			I_1	I_{max}	I_n	P_n	S_n	I_{Ld}	P_{Ld}	I_{Hd}
		A	A	A	kW	kVA	A	kW	A	kW
0585A-3	R10	585	730	585	315	405	575	315	429	250
0650A-3	R10	650	730	650	355	450	634	355	477	250
0725A-3	R11	725	1020	725	400	502	715	400	566	315
0820A-3	R11	820	1020	820	450	568	810	450	625	355
0880A-3	R11	880	1100	880	500	610	865	500	725***	400
1) At 25 °C (77 °F) ambient temperature the current is 451 A.										
$U_n = 500 V$										
0096A-5	R6	96	148	96	55	83	91	55	77	45
0124A-5	R6	124	178	124	75	107	118	75	96	55
0156A-5	R7	156	247	156	90	135	148	90	124	75
0180A-5	R7	180	287	180	110	156	171	110	156	90
0240A-5	R8	240	350	240	132	208	228	132	180	110
0260A-5	R8	260	418	260	160	225	247	160	240*	132
0361A-5	R9	361	542	361	200	313	343	200	302	200
0414A-5	R9	414	542	414	250	359	393	250	361**	200
0460A-5	R10	460	560	460	315	398	450	315	330	200
0503A-5	R10	503	560	503	355	436	483	315	361	250
0583A-5	R10	583	730	583	400	505	573	400	414	250
0635A-5	R10	635	730	635	450	550	623	450	477	315
0715A-5	R11	715	850	715	500	619	705	500	566	400
0820A-5	R11	820	1020	820	560	710	807	560	625	450
0880A-5	R11	880	1100	880	630	762	857	560	697*****	500
$U_n = 690 V$										
0061A-7	R6	61	104	61	55	73	58	55	49	45
0084A-7	R6	84	124	84	75	100	80	75	61	55
0098A-7	R7	98	168	98	90	117	93	90	84	75
0119A-7	R7	119	198	119	110	142	113	110	98	90
0142A-7	R8	142	250	142	132	170	135	132	119	110
0174A-7	R8	174	274	174	160	208	165	160	142	132
0210A-7	R9	210	384	210	200	251	200	200	174	160
0271A-7	R9	271	411	271	250	324	257	250	210	200
0330A-7	R10	330	480	330	315	394	320	315	255	250
0370A-7	R10	370	520	370	355	442	360	355	325	315
0430A-7	R10	430	520	430	400	514	420	400	360****	355
0470A-7	R11	470	655	470	450	562	455	450	415	400
0522A-7	R11	522	655	522	500	624	505	500	455	450
0590A-7	R11	590	800	590	560	705	571	560	505	500

IEC Ratings										
ACS880-07-...	Frame size	Input rating	Output ratings							
			No-overload use				Light-overload use		Heavy-duty use	
			I_1	I_{max}	I_n	P_n	S_n	I_{Ld}	P_{Ld}	I_{Hd}
		A	A	A	kW	kVA	A	kW	A	kW
0650A-7	R11	650	820	650	630	777	630	630	571****	560
0721A-7	R11	721	820	721	710	862	705	630	571****	560
3AXD10000044776										

UL (NEC) RATINGS										
ACS880-07-...	Frame size	Input rating	Max. current	App. power	Output ratings					
					Light-overload use			Heavy-duty use		
					I_1	I_{max}	S_n	I_{Ld}	P_{Ld}	
		A	A	kVA	A	kW	hp	A	kW	hp
$U_n = 480\text{ V}$										
0096A-5	R6	96	148	83	96	55	75	77	45	60
0124A-5	R6	124	178	107	124	75	100	96	55	75
0156A-5	R7	156	247	135	156	90	125	124	75	100
0180A-5	R7	180	287	156	180	110	150	156	90	125
0240A-5	R8	240	350	208	240	132	200	180	110	150
0302A-5	R9	302	498	262	302	200	250	260	132	200
0361A-5	R9	361	542	313	361	200	300	302	200	250
0414A-5	R9	414	542	359	414	250	350	361**	200	300
0503A-5	R10	503	560	436	483	315	400	361	250	300
0583A-5	R10	583	730	505	573	400	450	414	250	350
0635A-5	R10	635	730	550	623	450	500	477	315	400
0715A-5	R11	715	850	619	705	500	600	566	400	450
0820A-5	R11	820	1020	710	807	560	700	625	450	500
0880A-5	R11	880	1100	762	857	560	700	697***	500	600
$U_n = 600\text{ V}$										
0061A-7	R6	61	104	73	62	45	60	52	37	50
0084A-7	R6	84	124	100	77	55	75	62	45	60
0098A-7	R7	98	168	117	99	75	100	77	55	75
0119A-7	R7	119	198	142	125	90	125	99	75	100
0142A-7	R8	142	250	170	144	110	150	125	90	125
0174A-7 (See note 3 below)	R8	174	274	208	180	132	200	144	110	150
0210A-7	R9	210	384	251	242	160	250	192	132	200
0271A-7 (See note 4 below)	R9	271	411	324	271	200	250	242*	160	250
0330A-7	R10	330	480	394	336	315	350	255	250	250

UL (NEC) RATINGS										
ACS880-07-...	Frame size	Input rating	Max. current	App. power	Output ratings					
					Light-overload use			Heavy-duty use		
					I_1	I_{max}	S_n	I_{Ld}	P_{Ld}	
A	A	kVA	A	kW	hp	A	kW	hp		
0370A-7	R10	370	520	442	382	355	400	325	315	300
0430A-7	R10	430	520	514	424	400	450	360****	355	350
0470A-7	R11	470	655	562	472	450	500	415	400	450
0522A-7	R11	522	655	624	528	500	550	455	450	450
0590A-7	R11	590	800	705	571	560	600	505	500	500
0650A-7	R11	650	820	777	630	630	700	571****	560	600
0721A-7	R11	721	820	862	705	630	700	571****	560	600
3AXD10000044776										

■ Definitions

- U_n Nominal voltage of the drive. For the input voltage range, see section [Electrical power network specification \(page 224\)](#).
- I_1 Nominal rms input current
- I_n Nominal output current (available continuously with no over-loading)
- S_n Apparent power in no-overload use
- P_n Typical motor power in no-overload use
- I_{Ld} Continuous rms output current allowing 10% overload for 1 minute every 5 minutes.
- P_{Ld} Typical motor power in light-overload use
- I_{max} Maximum output current. Available for 10 seconds at start, then as long as allowed by drive temperature.
- I_{Hd} Continuous rms output current allowing 50% overload for 1 minute every 5 minutes.
 * Continuous rms output current allowing 30% overload for 1 minute every 5 minutes.
 ** Continuous rms output current allowing 25% overload for 1 minute every 5 minutes.
 *** Continuous rms output current allowing 40% overload for 1 minute every 5 minutes.
 **** Continuous rms output current allowing 44% overload for 1 minute every 5 minutes.
 ***** Continuous rms output current allowing 45% overload for 1 minute every 5 minutes.
- P_{Hd} Typical motor power in heavy-duty use

Note 1: The ratings apply at an ambient temperature of 40 °C (104 °F).

Note 2: To achieve the rated motor power given in the table, the rated current of the drive must be higher than or equal to the rated motor current.

The DriveSize dimensioning tool available from ABB is recommended for selecting the drive, motor and gear combination.

Note 3 – ACS880-07-0174A-7 amp rating: The drive can deliver 192 A continuously with no overload.

Note 4 – ACS880-07-0271A-7 power rating: The power rating is as per NEC Table 42.1. However, the drive can be used for a typical 4-pole motor rated to 300 hp meeting NEMA MG 1 Table 12-11 minimum efficiency standard (EPA efficiency electrical motors) if motor full load current is not more than 271 A.

Derating

■ Ambient temperature derating

In the temperature range +40...50 °C (+104...122 °F), the rated output current is derated by 1% for every added 1 °C (1.8 °F). The output current can be calculated by multiplying the current given in the rating table by the derating factor (k):

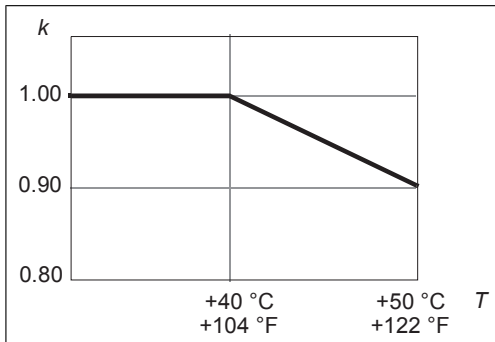

■ Altitude derating

At altitudes 1000 ... 2000 m (3281 ... 6562 ft) above sea level, the output current derating is 1 percentage point for every added 100 m (328 ft). For example, the derating factor for 1500 m (4921 ft) is 0.95. For altitudes above 2000 m (6562 ft), contact ABB.

If surrounding air temperature is below +40 °C, the derating can be reduced by 1.5 percentage points for every 1 °C reduction in temperature. A few altitude derating curves are shown below.

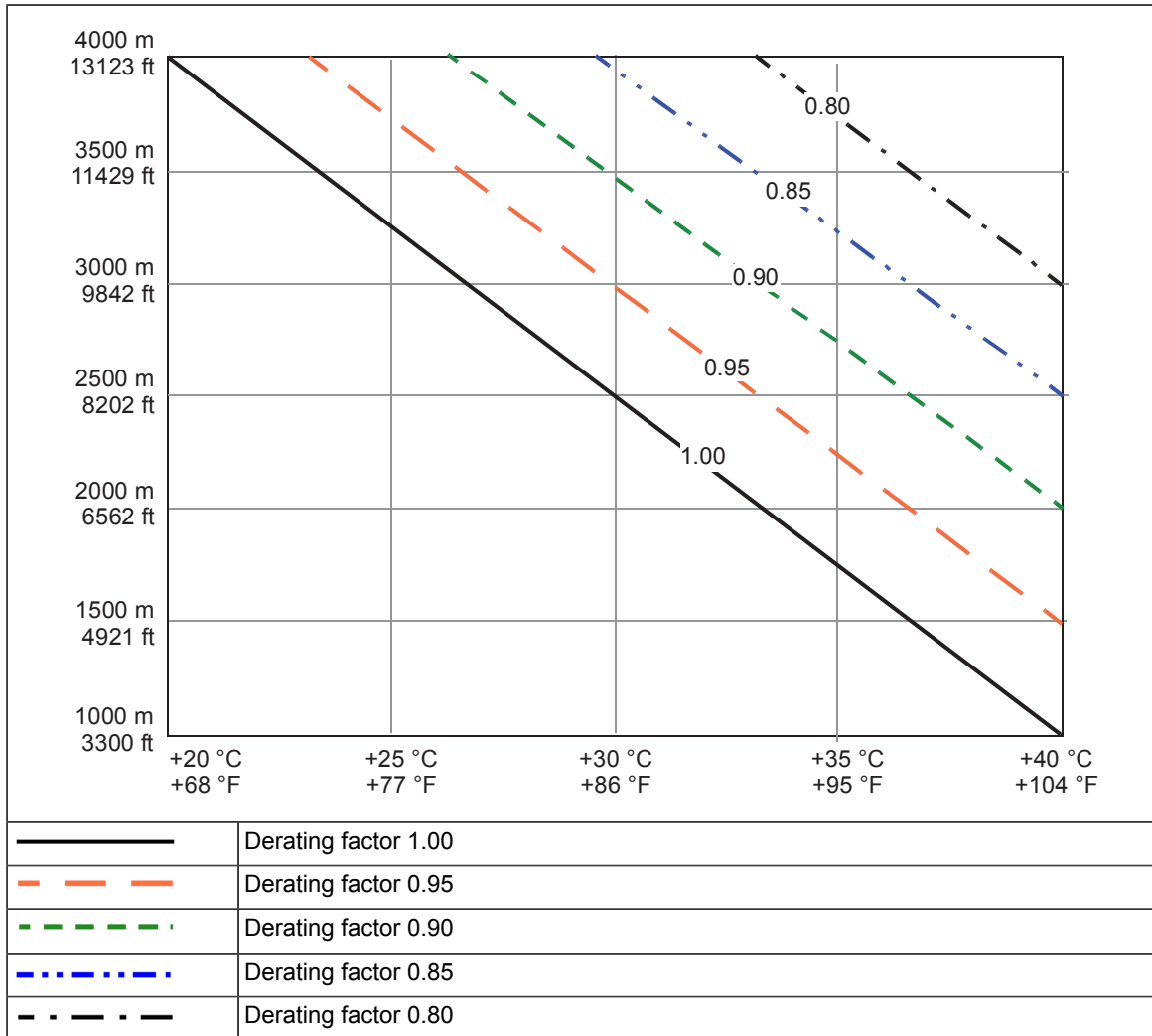

For a more accurate derating, use the DriveSize PC tool.

■ **Switching frequency derating**

Switching frequencies other than default can require output current derating. Contact ABB for more information.

■ **Deratings for special settings in the drive control program**

Enabling special settings in the drive control program can require output current derating.

Ex motor, sine filter, low noise

The table below gives the deratings for these cases:

- drive is used with an ABB motor for explosive atmospheres (Ex) and **EX motor** in *Parameter 95.15 Special HW settings* is enabled
- sine filter option +E206 is selected and **ABB sine filter** in *Parameter 95.15 Special HW settings* is enabled
- **Low noise optimization** is selected in *Parameter 97.09 Switching freq mode*.

For non-ABB Ex motors, contact ABB.

ACS880-07-...	Output ratings for special settings											
	Ex motor (ABB Ex motor)				ABB sine filter				Low noise mode			
	Nominal use		Light-duty use	Heavy-duty use	Nominal use		Light-duty use	Heavy-duty use	Nominal use		Light-duty use	Heavy-duty use
	I_n	P_n	I_{Ld}	I_{Hd}	I_n	P_n	I_{Ld}	I_{Hd}	I_n	P_n	I_{Ld}	I_{Hd}
	A	kW	A	A	A	kW	A	A	A	kW	A	A
$U_n = 400\text{ V}$												
0105A-3	97	45	92	87	91	45	86	77	86	37	82	67
0145A-3	134	55	127	97	126	55	120	91	118	55	112	86
0169A-3	160	75	152	134	152	75	144	126	146	75	139	118
0206A-3	195	90	185	160	186	90	177	152	178	90	169	146
0246A-3	225	110	214	195	209	110	199	186	194	90	184	178
0293A-3	269	132	256	225*	249	132	237	209*	236	132	224	194*
0363A-3	325	160	309	269	296	160	281	249	274	132	260	236
0430A-3	385	200	366	325**	352	160	334	296**	325	160	309	274**
0505A-3	479	250	459	345	470	250	450	340	390	200	370	290
0585A-3	551	250	533	395	540	250	518	383	437	250	419	311
0650A-3	613	315	591	438	600	315	576	425	485	250	466	346
0725A-3	667	355	650	493	647	355	628	468	519	250	496	390
0820A-3	753	400	737	544	731	400	712	517	587	315	562	431
0880A-3	809	450	786	631	785	450	760	600	630	355	600	500***
$U_n = 500\text{ V}$												
0096A-5	88	45	84	77	82	45	78	61	72	37	68	46
0124A-5	115	55	109	88	104	55	99	82	93	55	88	72
0156A-5	147	75	140	115	140	75	133	104	133	75	126	93
0180A-5	170	90	162	147	161	90	153	140	153	90	145	133
0240A-5	220	110	209	170	204	110	194	161	191	110	181	153
0260A-5	238	132	226	220*	221	110	210	204*	206	110	196	191*
0302A-5	270	160	257	238	242	132	230	221	206	110	196	191
0361A-5	322	200	306	270	289	160	275	242	258	160	245	206
0414A-5	370	200	352	322**	332	200	315	289**	296	160	281	258**
0460A-5	437	250	427	316	430	250	419	311	357	250	345	265
0503A-5	478	315	458	345	470	315	450	340	390	250	370	290
0583A-5	531	355	509	364	514	355	487	347	400	250	380	298
0635A-5	579	400	553	419	560	400	530	400	410	250	392	298
0715A-5	657	450	641	522	637	450	620	507	462	315	428	362
0820A-5	753	500	734	576	730	500	710	560	530	355	490	400
0880A-5	768	500	747	594	730	500	710	560	550	400	510	410
$U_n = 690\text{ V}$												
0061A-7	61	55	58	49	49	45	47	46	49	45	47	46
0084A-7	84	75	80	61	68	55	65	49	68	55	65	49
0098A-7	98	90	93	84	83	75	79	68	83	75	79	68

ACS880-07-...	Output ratings for special settings											
	Ex motor (ABB Ex motor)				ABB sine filter				Low noise mode			
	Nominal use		Light-duty use	Heavy-duty use	Nominal use		Light-duty use	Heavy-duty use	Nominal use		Light-duty use	Heavy-duty use
	I_n	P_n	I_{Ld}	I_{Hd}	I_n	P_n	I_{Ld}	I_{Hd}	I_n	P_n	I_{Ld}	I_{Hd}
	A	kW	A	A	A	kW	A	A	A	kW	A	A
0119A-7	119	110	113	98	101	90	96	83	101	90	96	83
0142A-7	126	110	120	119	112	90	106	90	101	90	96	84
0174A-7	154	132	146	126	137	110	130	112	122	110	116	101
0210A-7	184	160	175	154	161	132	153	137	138	132	131	122
0271A-7	238	200	226	184	207	160	197	161	178	160	169	138
0330A-7	310	250	300	217	303	250	293	204	232	200	222	157
0370A-7	348	315	338	276	340	315	330	260	260	250	250	200
0430A-7	378	355	368	315	360	355	350	300*	290	250	280	236*
0470A-7	388	355	376	335	360	355	349	308	270	250	261	238
0522A-7	431	400	417	370	400	355	388	342	300	250	290	262
0590A-7	485	450	470	449	450	400	436	385	340	315	330	300
0650A-7	575	500	555	480	550	500	530	450*	450	400	430	350****
0721A-7	593	500	574	480	550	500	530	450*	450	400	430	350****

The ratings apply at an ambient temperature of 40 °C (104 °F).

3AXD00000588487

U_n Nominal voltage of the drive

I_n Continuous rms output current. No overload capability at 40 °C (104 °F)

P_n Typical motor power in no-overload use.

I_{Ld} Continuous rms output current allowing 10% overload for 1 minute every 5 minutes

I_{Hd} Continuous rms output current allowing 50% overload for 1 minute every 5 minutes

* Continuous rms output current allowing 30% overload for 1 minute every 5 minutes.

** Continuous rms output current allowing 25% overload for 1 minute every 5 minutes.

*** Continuous rms output current allowing 40% overload for 1 minute every 5 minutes.

**** Continuous rms output current allowing 44% overload for 1 minute every 5 minutes.

■ High speed mode

Selection **High speed mode** of parameter *95.15 Special HW settings* improves control performance at high output frequencies. We recommend it to be selected with output frequency of 120 Hz and above.

This table gives the drive module ratings for 120 Hz output frequency and the maximum output frequency for the drive ratings when **High speed** mode in parameter *95.15 Special HW settings* is enabled.

With output frequencies smaller than the recommended maximum output frequency, the current derating is less than the values given in the table. Contact ABB for operation above the recommended maximum output frequency or for the output current derating with output frequencies above 120 Hz and below the maximum output frequency.

ACS880-07-...	Deratings with selection High speed mode of parameter 95.15 Special HW settings									
	120 Hz output frequency					Maximum output frequency				
		Nominal use		Light-duty use	Heavy-duty use		Nominal use		Light-duty use	Heavy-duty use
	f	I_n	P_n	I_{Ld}	I_{Hd}	f_{max}	I_n	P_n	I_{Ld}	I_{Hd}
	Hz	A	kW	A	A	Hz	A	kW	A	A
$U_n = 400\text{ V}$										
0105A-3	120	105	55	100	87	500	77	37	73	67
0145A-3	120	145	75	138	105	500	106	55	101	77
0169A-3	120	169	90	161	145	500	135	55	128	106
0206A-3	120	206	110	196	169	500	165	75	157	135
0246A-3	120	246	132	234	206	500	170	90	162	143
0293A-3	120	293	160	278	246*	500	202	110	192	170*
0363A-3	120	363	200	345	293	500	236	132	224	202
0430A-3	120	430	250	400	363**	500	280	160	266	236**
0505A-3	120	505	250	485	361	500	390	200	370	290
0585A-3	120	585	315	575	429	500	437	250	419	311
0650A-3	120	650	355	634	477	500	485	250	466	346
0725A-3	120	725	400	715	566	500	519	250	496	390
0820A-3	120	820	450	810	625	500	587	315	562	431
0880A-3	120	880	500	865	725***	500	630	355	600	500***
$U_n = 500\text{ V}$										
0096A-5	120	96	45	91	77	500	58	30	55	46
0124A-5	120	124	55	118	96	500	74	45	70	58
0156A-5	120	156	75	148	124	500	122	75	116	74
0180A-5	120	180	90	171	156	500	140	75	133	122
0240A-5	120	240	110	228	180	500	168	90	160	140
0260A-5	120	260	132	247	240*	500	182	110	173	168*
0302A-5	120	302	160	287	260	500	182	110	173	168
0361A-5	120	361	200	343	302	500	206	110	196	182
0414A-5	120	414	200	393	361**	500	236	132	224	206**
0460A-5	120	460	315	450	330	500	357	250	345	265
0503A-5	120	503	355	483	361	500	390	250	370	290
0583A-5	120	583	400	573	414	500	400	250	380	298
0635A-5	120	635	450	623	477	500	410	250	392	298
0715A-5	120	715	500	705	566	500	462	315	428	362
0820A-5	120	820	560	807	625	500	530	355	490	400
0880A-5	120	880	630	857	697****	500	550	400	510	410
$U_n = 690\text{ V}$										
0061A-7	120	61	55	58	49	500	44	37	42	40
0084A-7	120	84	75	80	61	500	53	45	50	44
0098A-7	120	98	90	93	84	500	68	55	65	53

ACS880-07-...	Deratings with selection High speed mode of parameter 95.15 Special HW settings									
	120 Hz output frequency					Maximum output frequency				
		Nominal use		Light-duty use	Heavy-duty use		Nominal use		Light-duty use	Heavy-duty use
	f	I_n	P_n	I_{Ld}	I_{Hd}	f_{max}	I_n	P_n	I_{Ld}	I_{Hd}
	Hz	A	kW	A	A	Hz	A	kW	A	A
0119A-7	120	119	110	113	98	500	83	75	79	68
0142A-7	120	142	132	135	119	500	83	75	79	72
0174A-7	120	174	160	165	142	500	96	90	91	83
0210A-7	120	210	200	200	174	500	101	90	96	83
0271A-7	120	271	200	257	210	500	130	110	124	101
0330A-7	120	330	315	320	255	375	232	200	222	157
0370A-7	120	370	355	360	325	375	260	250	250	200
0430A-7	120	430	400	420	360****	375	290	250	280	236****
0470A-7	120	470	450	455	415	375	270	250	261	238
0522A-7	120	522	500	505	455	375	300	250	290	262
0590A-7	120	590	560	571	505	375	340	315	330	300
0650A-7	120	650	630	630	571****	375	450	400	430	350****
0721A-7	120	721	710	705	571****	375	450	400	430	350****

The ratings apply at an ambient temperature of 40 °C (104 °F).

3AXD00000588487

f Output frequency

f_{max} Maximum output frequency with High speed mode

U_n Nominal voltage of the drive

I_n Continuous rms output current. No overload capability at 40 °C (104 °F)

P_n Typical motor power in no-overload use.

I_{Ld} Continuous rms output current allowing 10% overload for 1 minute every 5 minutes

P_{Ld} Typical motor power for light-overload use.

I_{Hd} Continuous rms output current allowing 50% overload for 1 minute every 5 minutes

* Continuous rms output current allowing 30% overload for 1 minute every 5 minutes

** Continuous rms output current allowing 25% overload for 1 minute every 5 minutes

*** Continuous rms output current allowing 40% overload for 1 minute every 5 minutes

**** Continuous rms output current allowing 44% overload for 1 minute every 5 minutes

***** Continuous rms output current allowing 45% overload for 1 minute every 5 minutes

Fuses (IEC)

The drive is equipped with aR fuses listed below.

ACS880-07-...	Input current (A)	Ultrarapid (aR) fuses (one fuse per phase)							
		Nominal current	Voltage rating	Bussmann			Mersen		
				A	V	Type	A ² s	Size	Type
$U_n = 400 \text{ V}$									
0105A-3	105	160	690	170M3814D	8250	1	-	-	-
0145A-3	145	250	690	170M3816D	31000	1	-	-	-
0169A-3	169	250	690	170M3816D	31000	1	-	-	-
0206A-3	206	315	690	170M3817D	52000	1	-	-	-
0246A-3	246	400	690	170M5808D	79000	2	-	-	-
0293A-3	293	500	690	170M5810D	155000	2	-	-	-
0363A-3	363	630	690	170M6410	210000	3	SC32AR69V630TF	315000	2
0430A-3	430	700	690	170M6411	300000	3	SC32AR69V700TF	442000	2
0505A-3	505	800	690	170M6412	465000	3	SC32AR69V800TF	660000	2
0585A-3	585	900	690	170M6413	670000	3	SC33AR69V900TF	805000	3
0650A-3	650	1000	690	170M6414	945000	3	SC33AR69V10CTF	1070000	3
0725A-3	725	1250	690	170M6416	1950000	3	SC33AR69V13CTF	2210000	3
0820A-3	820	1250	690	170M6416	1950000	3	SC33AR69V13CTF	2210000	3
0880A-3	880	1400	690	170M6417	2450000	3	SC33AR69V14CTF	3030000	3
$U_n = 500 \text{ V}$									
0096A-5	96	160	690	170M3814D	8250	1	-	-	-
0124A-5	124	250	690	170M3816D	31000	1	-	-	-
0156A-5	156	250	690	170M3816D	31000	1	-	-	-
0180A-5	180	315	690	170M3817D	52000	1	-	-	-
0240A-5	240	400	690	170M5808D	79000	2	-	-	-
0260A-5	260	500	690	170M5810D	155000	2	-	-	-
0361A-5	361	630	690	170M6410	210000	3	SC32AR69V630TF	315000	2
0414A-5	414	700	690	170M6411	300000	3	SC32AR69V700TF	442000	2
0460A-5	460	700	690	170M6411	300000	3	SC32AR69V700TF	442000	2
0503A-5	503	800	690	170M6412	465000	3	SC32AR69V800TF	660000	2
0583A-5	583	900	690	170M6413	670000	3	SC33AR69V900TF	805000	3
0635A-5	635	1000	690	170M6414	945000	3	SC33AR69V10CTF	1070000	3
0715A-5	715	1250	690	170M6416	1950000	3	SC33AR69V13CTF	2210000	3
0820A-5	820	1250	690	170M6416	1950000	3	SC33AR69V13CTF	2210000	3
0880A-5	880	1400	690	170M6417	2450000	3	SC33AR69V14CTF	3030000	3
$U_n = 690 \text{ V}$									
0061A-7	61	100	690	170M3812D	2600	1	-	-	-
0084A-7	84	160	690	170M3814D	8250	1	-	-	-
0098A-7	98	160	690	170M3814D	8250	1	-	-	-

ACS880-07-...	Input current (A)	Ultrarapid (aR) fuses (one fuse per phase)							
		Nominal current	Voltage rating	Bussmann			Mersen		
				A	V	Type	A ² s	Size	Type
0119A-7	119	250	690	170M3816D	31000	1	-	-	-
0142A-7	142	250	690	170M3816D	31000	1	-	-	-
0174A-7	174	315	690	170M3817D	52000	1	-	-	-
0210A-7	210	315	690	170M4410	42000	1	SC31AR69V315TF	47500	1
0271A-7	271	500	690	170M5410	145000	2	SC32AR69V500TF	160000	2
0330A-7	330	630	690	170M6410	210000	3	SC32AR69V630TF	315000	2
0370A-7	370	630	690	170M6410	210000	3	SC32AR69V630TF	315000	2
0430A-7	430	700	690	170M6411	300000	3	SC32AR69V700TF	442000	2
0470A-7	470	800	690	170M6412	465000	3	SC32AR69V800TF	660000	2
0522A-7	522	800	690	170M6412	465000	3	SC32AR69V800TF	660000	2
0590A-7	590	900	690	170M6413	670000	3	SC33AR69V900TF	805000	3
0650A-7	650	1000	690	170M6414	945000	3	SC33AR69V10CTF	1070000	3
0721A-7	721	1250	690	170M6416	1950000	3	SC33AR69V13CTF	2210000	3

Notes:

- 1 Fuses with a higher current rating than specified must not be used.
- 2 Fuses from other manufacturers can be used if they meet the ratings and the melting curve of the fuse does not exceed the melting curve of the fuse mentioned in the table.

Fuses (UL)

The drive is equipped with standard UL fuses listed below for branch circuit protection per NEC. Obey local regulations.

ACS880-07-...	Input current (A)	Fuse (one fuse per phase)					
		A	V	Bussmann type	With option +F289		UL class / Size
					A	Bussmann type	
$U_n = 480\text{ V}$							
0096A-5	96	250	600	DFJ-250	160	170M3414	J/1
0124A-5	124	250	600	DFJ-250	250	170M3416	J/1
0156A-5	156	300	600	DFJ-300	250	170M3416	J/1
0180A-5	180	300	600	DFJ-300	315	170M4410	J/1
0240A-5	240	400	600	DFJ-400	400	170M5408	J/2
0260A-5	260	400	600	DFJ-400	500	170M5410	J/2
0302A-5	375	630	690	170M6410	630	170M6410	3
0361A-5	361	630	690	170M6410	630	170M6410	3
0414A-5	414	700	690	170M6411	700	170M6411	3
0460A-5	460	700	690	170M6411	700	170M6411	3
0503A-5	503	800	690	170M6412	800	170M6412	3
0583A-5	583	900	690	170M6413	900	170M6413	3
0635A-5	635	1000	690	170M6414	1000	170M6414	3
0715A-5	715	1250	690	170M6416	1250	170M6416	3
0820A-5	820	1250	690	170M6416	1250	170M6416	3
0880A-5	880	1400	690	170M6417	1400	170M6417	3
$U_n = 600\text{ V}$							
0061A-7	61	250	600	DFJ-250	100	170M3412	J/1
0084A-7	84	250	600	DFJ-250	160	170M3414	J/1
0098A-7	98	250	600	DFJ-250	160	170M3414	J/1
0119A-7	119	250	600	DFJ-250	250	170M3416	J/1
0142A-7	142	250	600	DFJ-250	250	170M3416	J/1
0174A-7	174	300	600	DFJ-300	315	170M4410	J/1
0210A-7	210	315	690	170M4410	315	170M4410	1
0271A-7	271	500	690	170M5410	500	170M5410	2
0330A-7	330	630	690	170M6410	630	170M6410	3
0370A-7	370	630	690	170M6410	630	170M6410	3
0430A-7	430	700	690	170M6411	700	170M6411	3
0470A-7	470	800	690	170M6412	800	170M6412	3
0522A-7	522	800	690	170M6412	800	170M6412	3
0590A-7	590	900	690	170M6413	900	170M6413	3
0650A-7	650	1000	690	170M6414	1000	170M6414	3
0721A-7	721	1250	690	170M6416	1250	170M6416	3

Dimensions and weights

Frame size	Height ¹⁾				Width ²⁾		Depth ³⁾		Weight	
	IP22/42		IP54		mm	in.	mm	in.	kg	lb
	mm	in.	mm	in.						
R6	2145	84.43	2315	91.16	430	16.93	673	26.50	240	530
R7	2145	84.43	2315	91.16	430	16.93	673	26.50	250	560
R8	2145	84.43	2315	91.16	430	16.93	673	26.50	265	590
R9	2145	84.43	2315	91.16	830	32.68	698	27.48	375	830
R10	2145	84.43	2315	91.16	830	32.68	698	27.48	530	1170
R11	2145	84.43	2315	91.16	830	32.68	698	27.48	580	1280

1) For marine construction (option +C121) extra height is 10 mm (0.39 in.) due to the fastening bars at the bottom of the cabinet.

2) Extra width with brake resistors (option +D151): SAFURxxxFxxx 400 mm (15.75 in.), 2×SAFURxxxFxxx 800 mm (19.68 in.). Extra width for frames R6 to R8 with EMC filter (option +E202): 200 mm (7.87 in.). Total width of R6 to R9 frame sizes with molded case circuit breaker (option +F289) is 830 mm (32.68 in.).

3) For drives with marine fastening bars (option +C121): Depth is 757 mm.

■ Dimensions and weights of sine filter cubicle (option +E206)

Frame size	Height				Width		Depth		Weight	
	IP22/42		IP54		mm	in.	mm	in.	kg	lb
	mm	in.	mm	in.						
R6	2145	84.43	2315	91.16	600	23.62	646	25.43	280 to 330 *	617 to 728 *
R7	2145	84.43	2315	91.16	600	23.62	646	25.43	310 to 340 *	683 to 750 *
R8	2145	84.43	2315	91.16	600	23.62	646	25.43	330 to 430 *	728 to 948 *
R9	2145	84.43	2315	91.16	600	23.62	646	25.43	410 to 430 *	904 to 948 *
R10	2145	84.43	2315	91.16	400 or 1000	15.75 or 39.37	646	25.43	340 to 840 *	750 to 1852 *
R11	2145	84.43	2315	91.16	400 or 1000	15.75 or 39.37	646	25.43	340 to 840 *	750 to 1852 *

* Depends on the drive and sine filter type.

Free space requirements

Front		Side		Above *	
mm	in	mm	in	mm	in
150	5.91	-	-	400	15.75

* measured from the base plate of the cabinet top.

Losses, cooling data and noise

Drive type	Frame	Air flow		Heat dissipation W	Noise dB (A)
		m ³ /h	ft ³ /min		
$U_n = 400 \text{ V}$					
ACS880-07-0105A-3	R6	1750	1130	1795	67
ACS880-07-0145A-3	R6	1750	1130	1940	67
ACS880-07-0169A-3	R7	1750	1130	2440	67
ACS880-07-0206A-3	R7	1750	1130	2810	67
ACS880-07-0246A-3	R8	1750	1130	3800	65
ACS880-07-0293A-3	R8	1750	1130	4400	65
ACS880-07-0363A-3	R9	1150	677	5300	68
ACS880-07-0430A-3	R9	1150	677	6500	68
ACS880-07-0505A-3	R10	2950	1837	6102	72
ACS880-07-0585A-3	R10	2950	1837	6909	72
ACS880-07-0650A-3	R10	2950	1837	8622	72
ACS880-07-0725A-3	R11	2950	1837	9264	72
ACS880-07-0820A-3	R11	2950	1837	10362	72

212 Technical data

Drive type	Frame	Air flow		Heat dissipation W	Noise dB (A)
		m ³ /h	ft ³ /min		
ACS880-07-0880A-3	R11	3170	1978	11078	71
U_n = 500 V					
ACS880-07-0096A-5	R6	1750	1130	1795	67
ACS880-07-0124A-5	R6	1750	1130	1940	67
ACS880-07-0156A-5	R7	1750	1130	2440	67
ACS880-07-0180A-5	R7	1750	1130	2810	67
ACS880-07-0240A-5	R8	1750	1130	3800	65
ACS880-07-0260A-5	R8	1750	1130	4400	65
ACS880-07-0302A-5	R9	1150	677	4700	68
ACS880-07-0361A-5	R9	1150	677	5300	68
ACS880-07-0414A-5	R9	1150	677	6500	68
ACS880-07-0460A-5	R10	2950	1837	4903	72
ACS880-07-0503A-5	R10	2950	1837	6102	72
ACS880-07-0583A-5	R10	2950	1837	6909	72
ACS880-07-0635A-5	R10	2950	1837	8622	72
ACS880-07-0715A-5	R11	2950	1837	9264	72
ACS880-07-0820A-5	R11	2950	1837	10362	71
ACS880-07-0880A-5	R11	2950	1837	11078	71
U_n = 690 V					
ACS880-07-0061A-7	R6	1750	1130	1795	67
ACS880-07-0084A-7	R6	1750	1130	1940	67
ACS880-07-0098A-7	R7	1750	1130	2440	67
ACS880-07-0119A-7	R7	1750	1130	2810	67
ACS880-07-0142A-7	R8	1750	1130	3800	65
ACS880-07-0174A-7	R8	1750	1130	4400	65
ACS880-07-0210A-7	R9	1150	677	4700	68
ACS880-07-0271A-7	R9	1150	677	5300	68
ACS880-07-0330A-7	R10	2950	1837	5640	72
ACS880-07-0370A-7	R10	2950	1837	6371	72
ACS880-07-0430A-7	R10	2950	1837	7570	72
ACS880-07-0470A-7	R11	2950	1837	6611	72
ACS880-07-0522A-7	R11	2950	1837	7388	72
ACS880-07-0590A-7	R11	2950	1837	8971	71
ACS880-07-0650A-7	R11	3170	1978	9980	71
ACS880-07-0721A-7	R11	3170	1978	11177	71

Cooling data and noise for drives with sine filter (option +E206)

ACS880-07-...	Frame	Sine filter type	Heat dissipation			Air flow			Noise
			Drive	Filter	Total	Drive	Filter	Total	
			kW	kW	kW	m ³ /h	m ³ /h	m ³ /h	dBA
<i>U_n</i> = 400 V									
0105A-3	R6	B84143V0130S230	1.8	0.6	2.4	1750	*	1750	80
0145A-3	R6	B84143V0162S229	1.9	0.6	2.5	1750	*	1750	80
0169A-3	R7	B84143V0162S229	2.4	0.6	3.0	1750	*	1750	80
0206A-3	R7	B84143V0230S229	2.8	0.9	3.7	1750	*	1750	80
0246A-3	R8	B84143V0230S229	3.8	0.9	4.7	1750	*	1750	80
0293A-3	R8	B84143V0390S229	4.4	1.6	6.0	1750	*	1750	80
0363A-3	R9	B84143V0390S229	5.3	1.6	6.9	1150	*	1150	80
0430A-3	R9	B84143V0390S229	6.5	1.6	8.1	1150	*	1150	80
0505A-3	R10	NSIN0900-6	6.1	3.0	9.1	2950	2000	4950	80
0585A-3	R10	NSIN0900-6	6.9	3.4	11.3	2950	2000	4950	80
0650A-3	R10	NSIN0900-6	8.6	3.8	12.4	2950	2000	4950	80
0725A-3	R11	NSIN0900-6	9.2	4.1	13.3	2950	2000	4950	80
0820A-3	R11	NSIN0900-6	10.4	4.7	15.4	2950	2000	4950	80
0880A-3	R11	NSIN0900-6	11.1	5.0	16.1	3170	2000	5170	80
<i>U_n</i> = 500 V									
0096A-5	R6	B84143V0130R230	1.8	0.6	2.4	1750	*	1750	80
0124A-5	R6	B84143V0130R230	1.9	0.6	2.5	1750	*	1750	80
0156A-5	R7	B84143V0162R229	2.4	0.6	3.0	1750	*	1750	80
0180A-5	R7	B84143V0162S229	2.8	0.6	3.4	1750	*	1750	80
0240A-5	R8	B84143V0230S229	3.8	0.9	4.7	1750	*	1750	80
0260A-5	R8	B84143V0230S229	4.4	0.9	5.3	1750	*	1750	80
0361A-5	R9	B84143V0390S229	5.3	1.6	6.9	1150	*	1150	80
0414A-5	R9	B84143V0390S229	6.5	1.6	8.1	1150	*	1150	80
0460A-5	R10	NSIN0485-6	4.9	3.3	7.2	2950	700	3650	80
0503A-5	R10	NSIN0900-6	6.1	3.6	9.7	2950	2000	4950	80
0583A-5	R10	NSIN0900-6	6.9	3.9	10.8	2950	2000	4950	80
0635A-5	R10	NSIN0900-6	8.6	4.3	12.9	2950	2000	4950	80
0715A-5	R11	NSIN0900-6	9.3	4.9	14.2	2950	2000	4950	80
0820A-5	R11	NSIN0900-6	10.4	5.6	16	2950	2000	4950	80
0880A-5	R11	NSIN0900-6	11.1	5.6	16.7	2950	2000	4950	80
<i>U_n</i> = 690 V									
0061A-7	R6	B84143V0056S230	1.8	0.3	2.1	1750	*	1750	78
0084A-7	R6	B84143V0092S230	1.9	0.6	2.5	1750	*	1750	79
0098A-7	R7	B84143V0092S230	2.4	0.6	3	1750	*	1750	79
0119A-7	R7	B84143V0130S230	2.8	0.6	3.4	1750	*	1750	80
0142A-7	R8	B84143V0130S230	3.8	0.6	4.4	1750	*	1750	80

ACS880-07-...	Frame	Sine filter type	Heat dissipation			Air flow			Noise
			Drive	Filter	Total	Drive	Filter	Total	
			kW	kW	kW	m ³ /h	m ³ /h	m ³ /h	dB(A)
0174A-7	R8	B84143V0207S230	4.4	0.9	5.3	1750	*	1750	80
0210A-7	R9	B84143V0207S230	4.7	0.9	5.6	1150	*	1150	80
0271A-7	R9	B84143V0207S230	5.3	0.9	6.2	1150	*	1150	80
0330A-7	R10	NSIN0485-6	5.6	2.2	7.8	2950	700	3650	80
0370A-7	R10	NSIN0485-6	6.4	2.3	8.7	2950	700	3650	80
0430A-7	R10	NSIN0485-6	7.6	2.4	10	2950	700	3650	80
0470A-7	R11	NSIN0485-6	6.6	3.2	9.8	2950	700	3650	80
0522A-7	R11	NSIN0485-6	7.4	3.6	11	2950	700	3650	80
0590A-7	R11	NSIN0900-6	9	4.0	13	2950	2000	4950	80
0650A-7	R11	NSIN0900-6	10	4.9	14.9	3170	2000	5170	80
0721A-7	R11	NSIN0900-6	11.2	4.9	16.1	3170	2000	5170	80

* Natural convection
Sine filter is not available for ACS880-07-0302A-5.

Typical power cable sizes

The table below gives copper and aluminum cable types with concentric copper shield for the drives with nominal current. For the cable sizes accepted by the drive cabinet entries and connection terminals, see [Terminal and entry data for the power cables \(page 216\)](#).

Drive type	Frame size	IEC 1)		US 2)
		Cu cable type	Al cable type	Cu cable type
		mm ²	mm ²	AWG/kcmil per phase
$U_n = 400 \text{ V}$				
ACS880-07-0105A-3	R6	3×50	3×70	1
ACS880-07-0145A-3	R6	3×95	3×120	2/0
ACS880-07-0169A-3	R7	3×120	3×150	3/0
ACS880-07-0206A-3	R7	3×150	3×240	250 MCM
ACS880-07-0246A-3	R8	2 × (3×70)	2 × (3×95)	300 MCM
ACS880-07-0293A-3	R8	2 × (3×95)	2 × (3×120)	2 × 3/0
ACS880-07-0363A-3	R9	2 × (3×120)	2 × (3×185)	2 × 4/0
ACS880-07-0430A-3	R9	2 × (3×150)	2 × (3×240)	2 × 250 MCM
ACS880-07-0505A-3	R10	3 × (3×95)	3 × (3×150)	2×500 MCM or 3×250 MCM
ACS880-07-0585A-3	R10	3 × (3×120)	3 × (3×185)	2×600 MCM or 3×300 MCM
ACS880-07-0650A-3	R10	3 × (3×150)	3 × (3×240)	2×700 MCM or 3×350 MCM
ACS880-07-0725A-3	R11	3 × (3×185)	4 × (3×185)	3×500 MCM or 4×300 MCM
ACS880-07-0820A-3	R11	3 × (3×240)	4 × (3×240)	3×600 MCM or 4×400 MCM
ACS880-07-0880A-3	R11	3 × (3×240)	4 × (3×240)	3×600 MCM or 4×400 MCM
$U_n = 500 \text{ V}$				
ACS880-07-0096A-5	R6	3×50	3×70	1
ACS880-07-0124A-5	R6	3×95	3×95	2/0

Drive type	Frame size	IEC 1)		US 2)
		Cu cable type	Al cable type	Cu cable type
		mm ²	mm ²	AWG/kcmil per phase
ACS880-07-0156A-5	R7	3×120	3×150	3/0
ACS880-07-0180A-5	R7	3×150	3×185	250 MCM
ACS880-07-0240A-5	R8	2 × (3×70)	2 × (3×95)	300 MCM
ACS880-07-0260A-5	R8	2 × (3×70)	2 × (3×95)	2 × 2/0
ACS880-07-0302A-5	R9	2 × (3×95)	2 × (3×120)	2 × 3/0
ACS880-07-0361A-5	R9	2 × (3×120)	2 × (3×185)	2 × 250 MCM
ACS880-07-0414A-5	R9	2 × (3×150)	2 × (3×240)	2 × 250 MCM
ACS880-07-0460A-5	R10	3 × (3×95)	3 × (3×150)	2×400 MCM or 3×4/0
ACS880-07-0503A-5	R10	3 × (3×95)	3 × (3×150)	2×500 MCM or 3×250 MCM
ACS880-07-0583A-5	R10	3 × (3×120)	3 × (3×185)	2×600 MCM or 3×300 MCM
ACS880-07-0635A-5	R10	3 × (3×150)	3 × (3×240)	2×700 MCM or 3×350 MCM
ACS880-07-0715A-5	R11	3 × (3×185)	4 × (3×185)	3×500 MCM or 4×300 MCM
ACS880-07-0820A-5	R11	3 × (3×240)	4 × (3×240)	3×600 MCM or 4×400 MCM
ACS880-07-0880A-5	R11	3 × (3×240)	4 × (3×240)	3×600 MCM or 4×400 MCM
$U_n = 690 \text{ V}$				
ACS880-07-0061A-7	R6	3×25	3×35	4
ACS880-07-0084A-7	R6	3×35	3×50	3
ACS880-07-0098A-7	R7	3×50	3×70	2
ACS880-07-0119A-7	R7	3×70	3×95	1/0
ACS880-07-0142A-7	R8	3×95 3)	3×120	2/0
ACS880-07-0174A-7	R8	3×120 3)	2 × (3×70)	4/0
ACS880-07-0210A-7	R9	3×185	2 × (3×95)	300 MCM
ACS880-07-0271A-7	R9	3×240	2 × (3×120)	400 MCM
ACS880-07-0330A-7	R10	2 × (3×120)	3 × (3×120)	2×250 MCM or 3×2/0
ACS880-07-0370A-7	R10	2 × (3×120)	3 × (3×120)	2×300 MCM or 3×3/0
ACS880-07-0430A-7	R10	3 × (3×95)	3 × (3×120)	2×350 MCM or 3×4/0
ACS880-07-0470A-7	R11	3 × (3×95)	3 × (3×150)	2×400 MCM or 3×4/0
ACS880-07-0522A-7	R11	3 × (3×120)	3 × (3×185)	2×500 MCM or 3×250 MCM
ACS880-07-0590A-7	R11	3 × (3×150)	3 × (3×185)	2×600 MCM or 3×300 MCM
ACS880-07-0650A-7	R11	3 × (3×150)	3 × (3×240)	2×700 MCM or 3×350 MCM
ACS880-07-0721A-7	R11	3 × (3×185)	4 × (3×185)	3×500 MCM or 4×300 MCM
3AXD10000044776				

The cable sizing is based on max. 9 cables laid on a cable ladder side by side, three ladder type trays one on top of the other, ambient temperature 30 °C, PVC insulation, surface temperature 70 °C (EN 60204-1 and IEC 60364-5-52/2001). For other conditions, size the cables according to local safety regulations, appropriate input voltage and the load current of the drive.

The cable sizing is based on NEC Table 310-16 for copper wires, 75 °C (167 °F) wire insulation at 40 °C (104 °F) ambient temperature. Not more than three current-carrying conductors in raceway or cable or earth (directly buried). For other conditions, size the

cables according to local safety regulations, appropriate input voltage and the load current of the drive.

Terminal and entry data for the power cables

■ IEC

Frame	Number of holes in the entry plate for the power cables. Hole diameter 60 mm.	Terminals L1, L2, L3, U2, V2, W2, UDC+/R+, UDC- and R-			Grounding terminals	
		Max. phase conductor size	Bolt size	Tightening torque	Bolt size	Tightening torque
		mm ²				N·m
R6	6	185	M10	20...40 N·m	M10	30...44 N·m
R7	6	185				
R8	6	1×240 or 2×185	M12	50...75 N·m		
R9	9	3×240				
R10	12	3×240 or 4×185				
R11	12	3×240 or 4×185				

■ US

Frame	Terminals L1, L2, L3, U2, V2, W2, UDC+/R+, UDC- and R-			Grounding terminals	
	Max. phase conductor size	Busbar bolt size – Hole spacing	Tightening torque	Bolt size	Tightening torque
	AWG/kcmil		bf-ft		bf-ft
R6	350 MCM	M10 (3/8") × 2 – 1.75"	15...30	M10 (3/8")	22...32
R7					
R8	1×500 MCM or 2×350 MCM	M12 (7/16") × 2 – 1.75"	37...55		
R9	3×500 MCM				
R10	3×500 MCM or 4×350 MCM	M12 (7/16") × 4 – 1.75"			
R11	3×500 MCM or 4×350 MCM				

The location and size of power cable terminals are shown in the drawings below.

Input and motor cable terminal dimensions of frames R6 to R7	
<p>Bottom entry and exit:</p>	<p>Top entry and exit:</p>
Input and motor cable terminal dimensions of frame R8	
<p>Bottom entry and exit:</p>	<p>Top entry and exit:</p>
Resistor and DC cable terminal dimensions of frames R6 to R8	
<p>Bottom entry and exit:</p>	

Power cable terminal dimensions of frame R8

Top entry and exit:

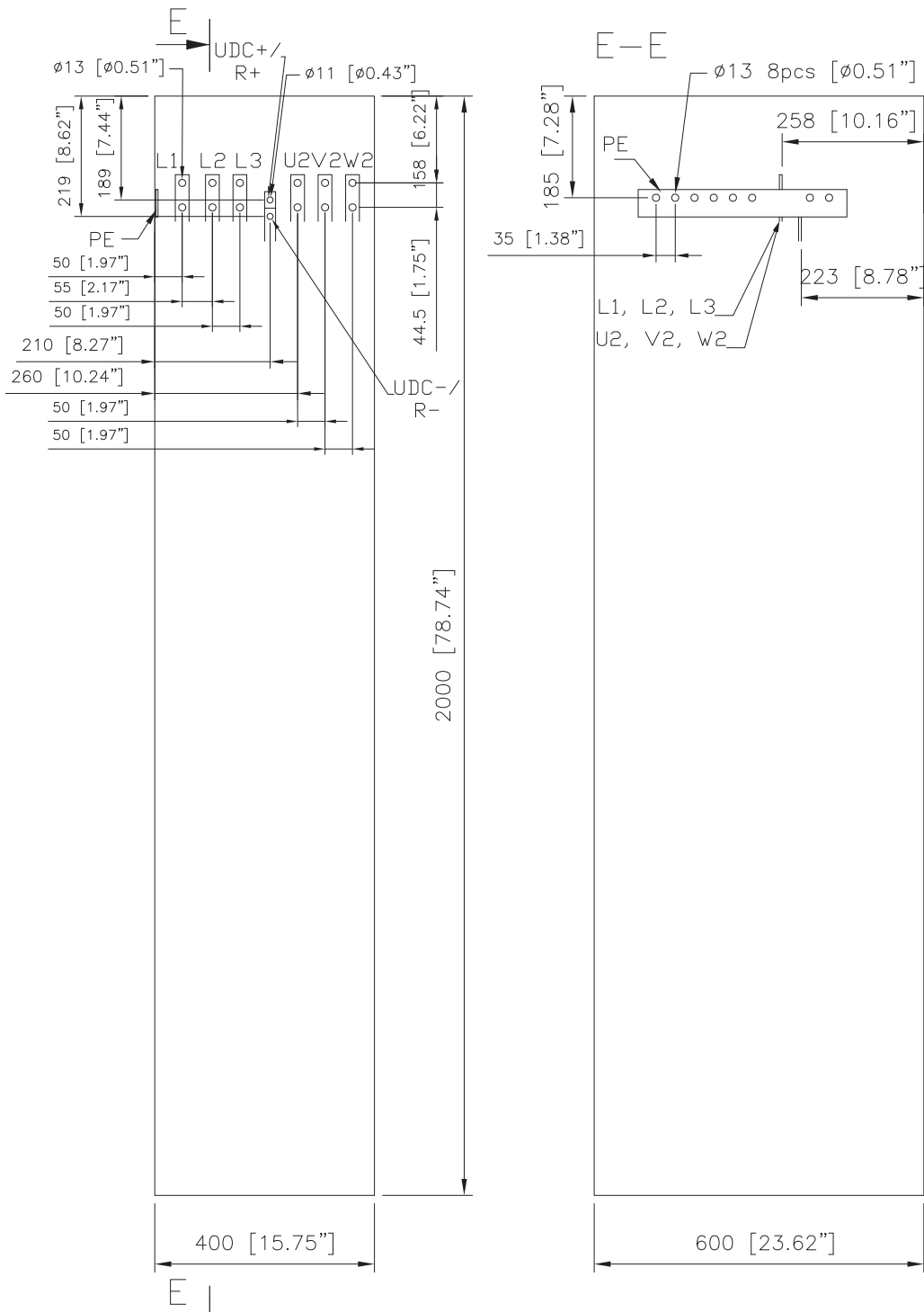

Motor cable terminal dimensions of frame R9

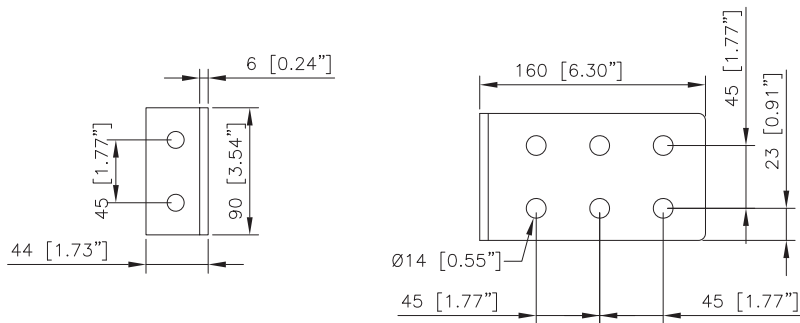

Input cable terminal dimensions of frame R9:

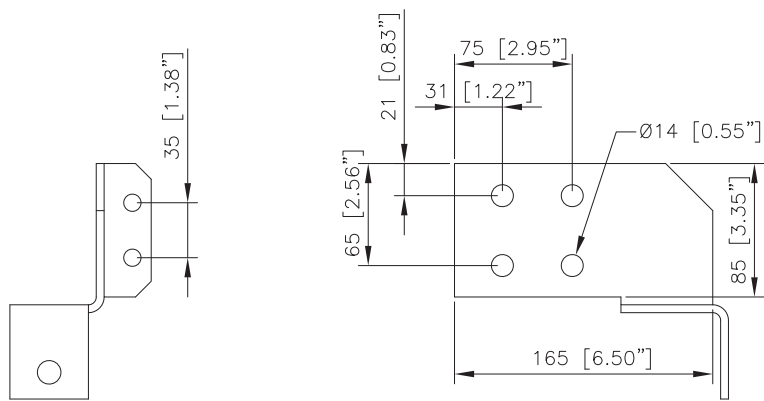

Resistor and DC cable terminal dimensions of frames R9:

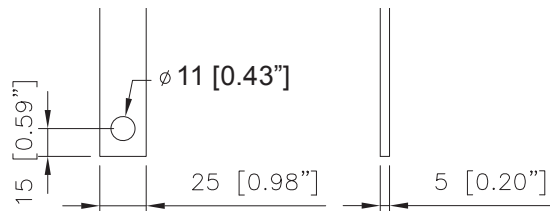

Input and motor cable terminal dimensions of frame R10

Bottom entry and exit:

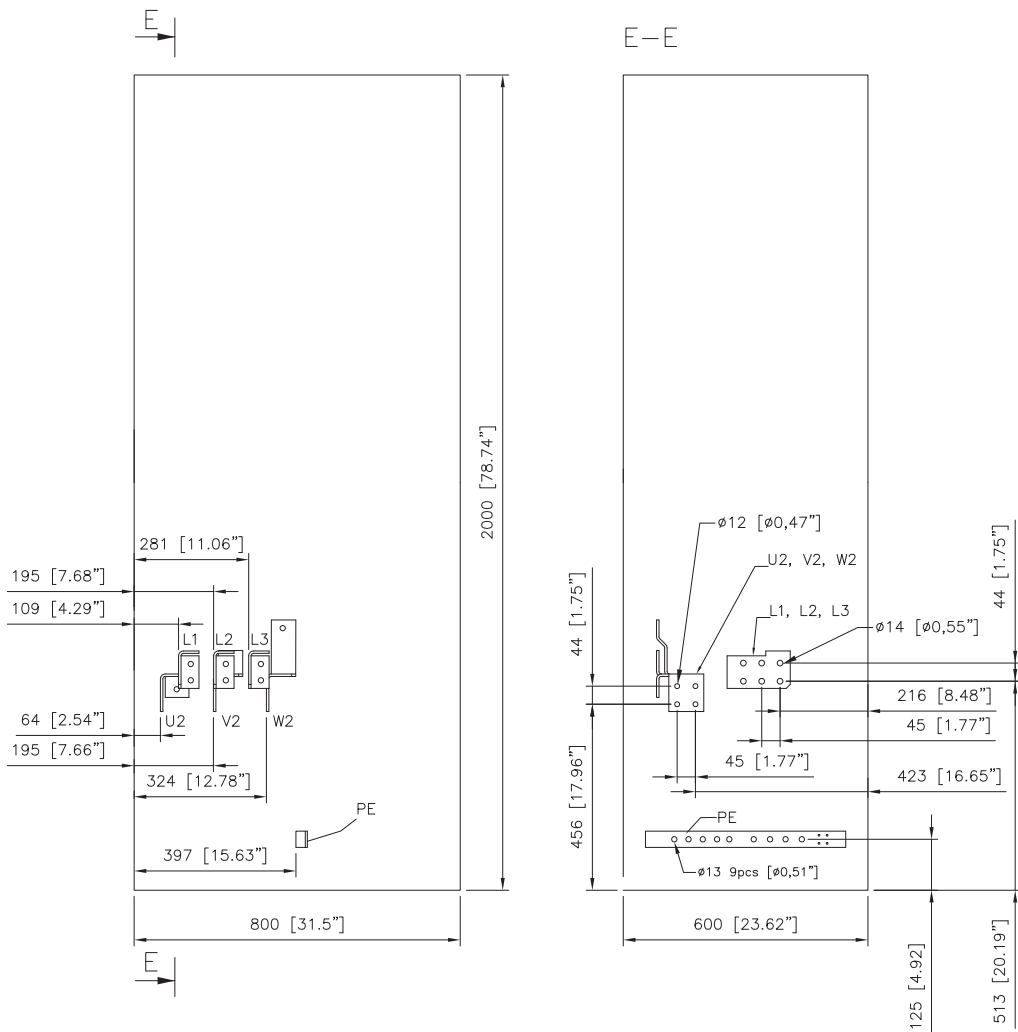

Input and motor cable terminal dimensions of frame R11

Bottom entry and exit:

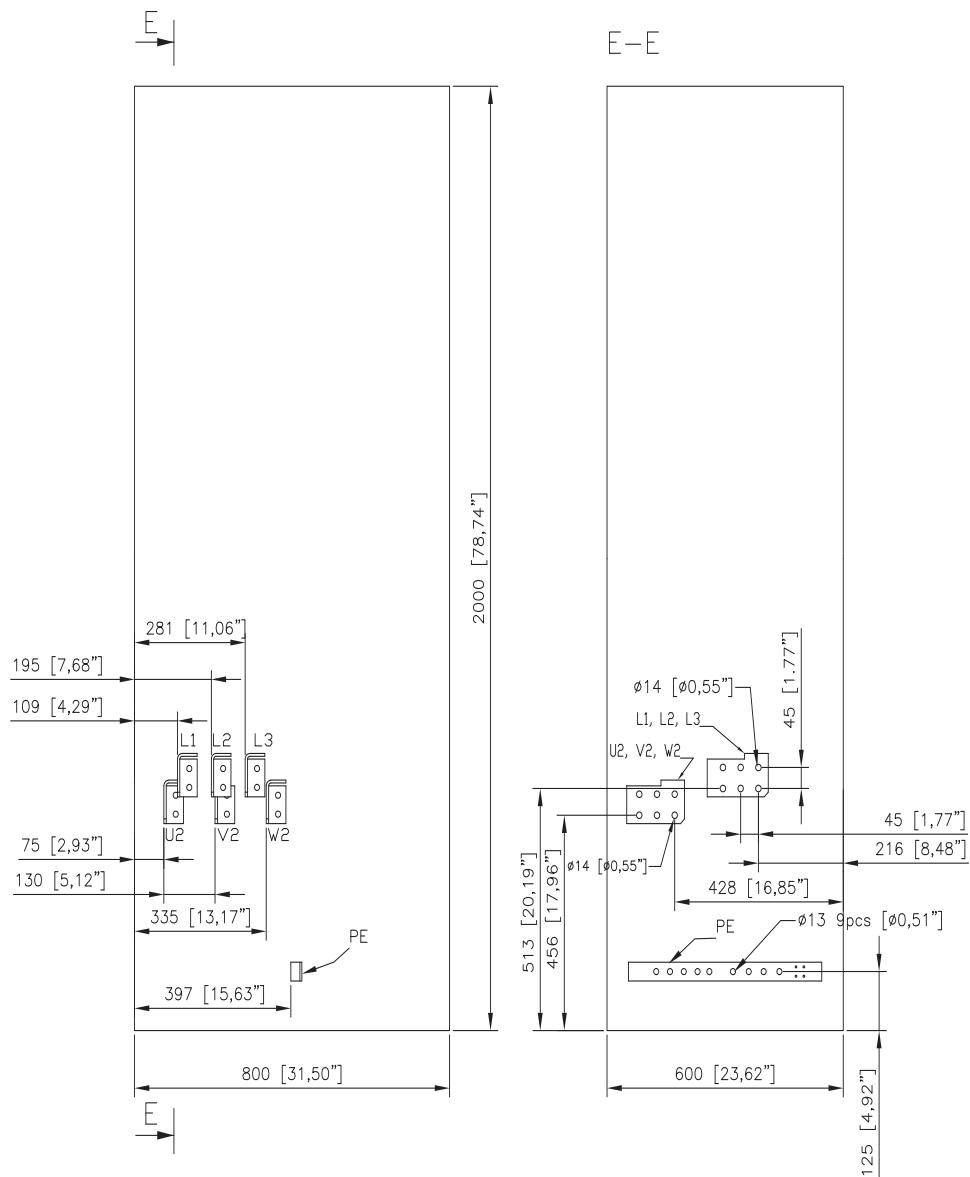

Input and motor cable terminal dimensions of frames R10 and R11

Top entry and exit (options +H351 and +H353):

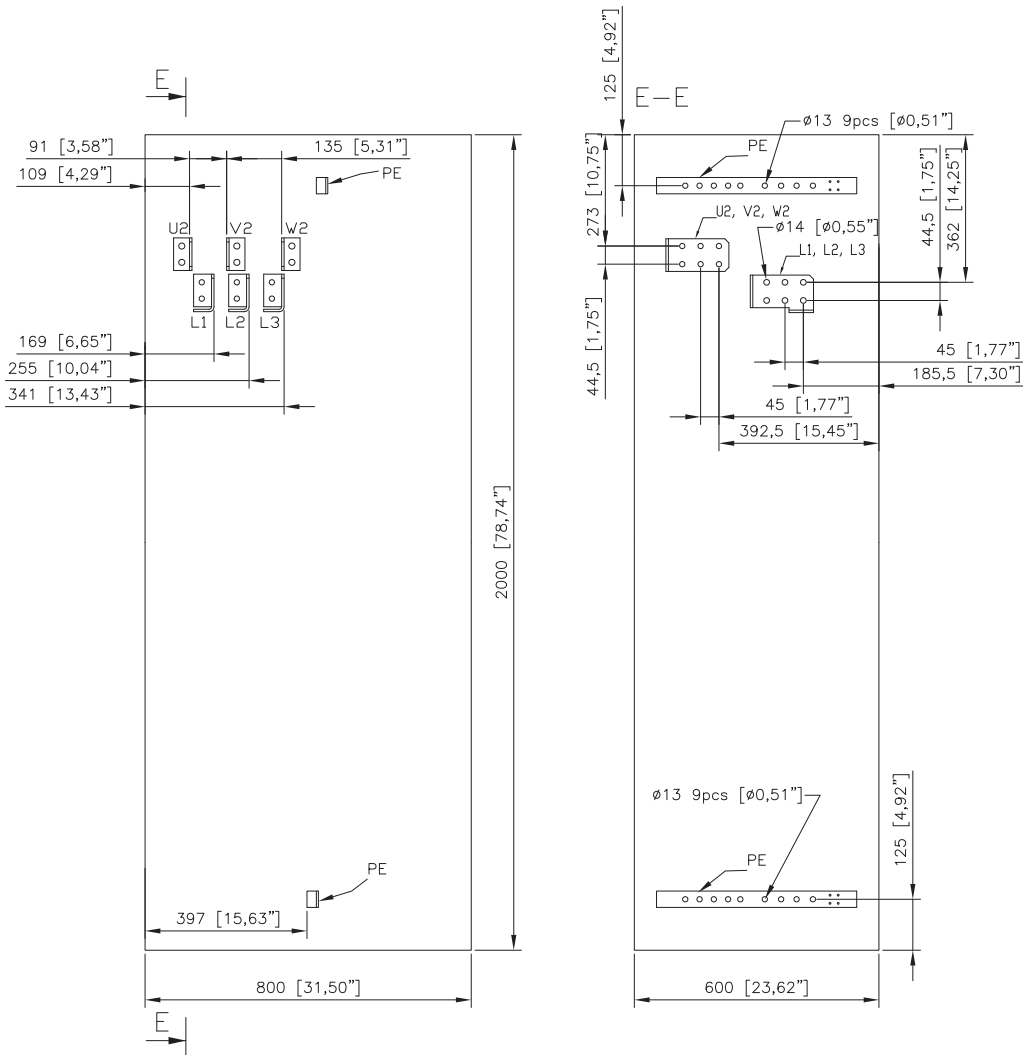

Input and motor cable terminal dimensions of frames R10 and R11

Top entry and exit (options +C129 +F277 +F289):

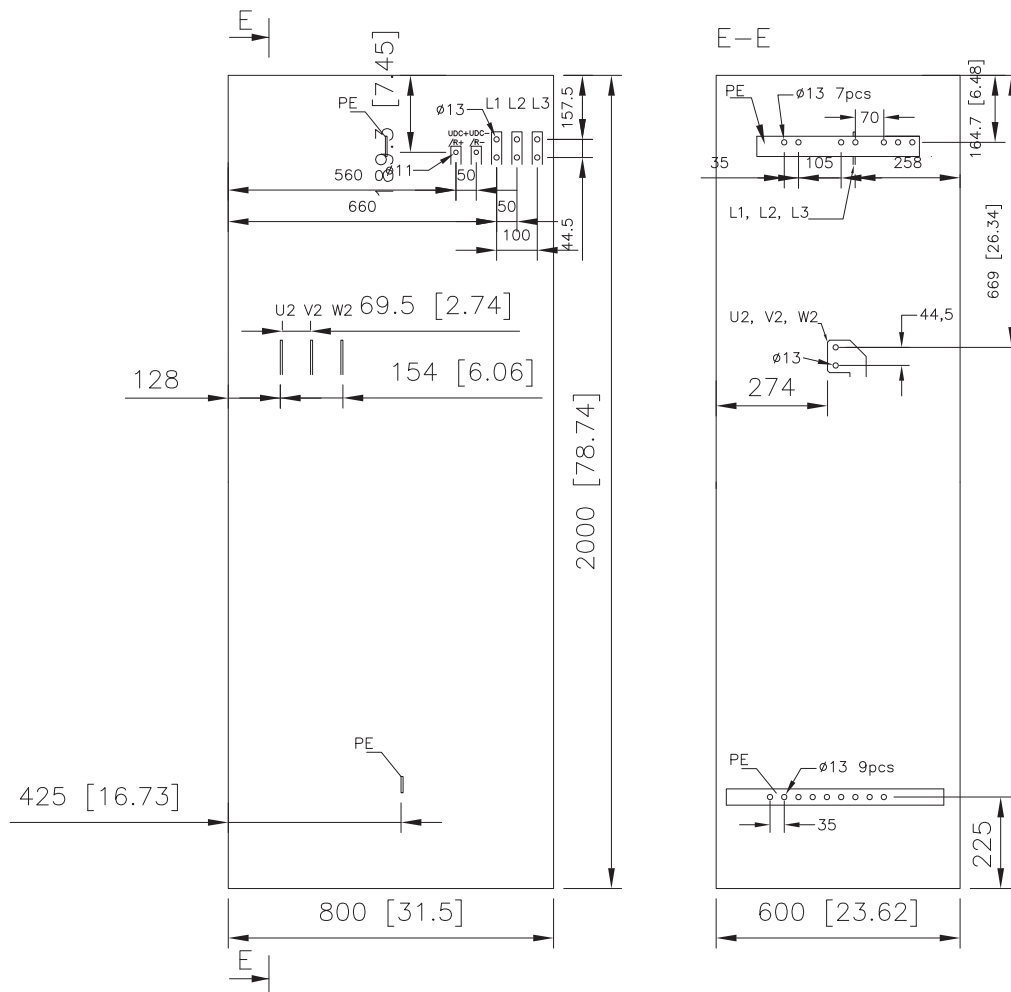

Terminal data for the control cables

See chapter *Control units of the drive* on page 90.

Electrical power network specification

Voltage (U_1)	<p><u>ACS880-07-xxxx-3 drives</u>: 380...415 V AC 3-phase +10%...-10%. This is indicated in the type designation label as typical input voltage level 3 ~ 400VAC</p> <p><u>ACS880-07-xxxx-5 drives</u>: 380...500 V AC 3-phase +10%...-10%. This is indicated in the type designation label as typical input voltage levels 3 ~ 400/480/500 V AC</p> <p><u>ACS880-07-xxxx-7 drives</u>: 525...690 V AC 3-phase +10%...-10%. This is indicated in the type designation label as typical input voltage levels 3 ~ 525/600/690 V AC.</p>
Network type	TN (grounded) and IT (ungrounded) systems
Short-circuit withstand strength I_{cc} (IEC/EN 61439- 1)	<p>Maximum allowable prospective short-circuit current is 65 kA when the input cable is protected with gG type fuses (IEC 60269) having maximum current rating as follows:</p> <ul style="list-style-type: none"> •400 A for frames R6 to R8 •630 A for frame R9 •1250 A for frames R10 and R11.
Short-circuit current protection (UL 508A)	The drive is suitable for use on a circuit capable of delivering not more than 100,000 rms symmetrical amperes at 600 V maximum when the input cable is protected with T class fuses.
Short-circuit current protection (CSA C22.2 No. 14-05)	The drive is suitable for use on a circuit capable of delivering not more than 100 kA rms symmetrical amperes at 600 V maximum when the input cable is protected with T class fuses.
Frequency (f_1)	50/60 Hz. Variation +5% of the nominal frequency.
Imbalance	Max. \pm 3% of nominal phase-to-phase input voltage
Fundamental power factor ($\cos \phi_1$)	0.98 (at nominal load)

Motor connection data

Motor types	Asynchronous AC induction motors, permanent magnet synchronous motors, AC induction servomotors and ABB synchronous reluctance motors (SynRM motors) with option +N7502
Voltage (U_2)	0 to U_1 , 3-phase symmetrical, This is indicated in the type designation label as typical output voltage level as 3 ~ 0... U_1 , U_{max} at the field weakening point
Frequency (f_2)	<p>0...500 Hz</p> <p><u>For drives with du/dt filter</u>: 120 Hz (frames R6 to R9), 200 Hz (frames (R10 and R11)</p> <p><u>For drives with sine filter</u>: 120 Hz</p>
Current	See section Ratings (page 197)
Switching frequency	<p><u>For frames R6 to R9</u>: 2.7 kHz (typically)</p> <p><u>For frames R10 and R11</u>: 3 kHz (typically)</p> <p>The switching frequency can vary per frame and voltage. For exact values, contact your local ABB representative.</p>

Maximum recommended motor cable length	<p>For frames R6 to R9: 300 m (984 ft). For frames R10 and R11: 500 m (1640 ft).</p> <p>Note: For frames R6 to R9 with motor cables longer than 150 m (492 ft) and for frames R10 and R11 with motor cables longer than 100 m (328 ft), the EMC Directive requirements may not be fulfilled.</p> <p>Note: Longer cables cause a motor voltage decrease which limits the available motor power. The decrease depends on the motor cable length and characteristics. Contact ABB for more information. A sine filter (option +E206) at the drive output also causes a voltage decrease.</p>
--	---

Control unit connection data

See chapter [Control units of the drive \(page 141\)](#).

Efficiency

Approximately 98% at nominal power level.

Protection classes

Degrees of protection(IEC/EN 60529) (IEC/EN 60529)	IP22, IP42, IP54
Enclosure types (UL50)	UL Type 1, UL Type 1 Filtered, UL Type 12. For indoor use only.
Overvoltage category (IEC/EN 60664-1)	III
Protective class (IEC/EN 61800-5-1)	I

Ambient conditions

Environmental limits for the drive are given below. The drive is to be used in a heated, indoor, controlled environment.

	Operation installed for stationary use	Storage in the protective package	Transportation in the protective package
Installation site altitude	0...2000 m (0...6562 ft) above sea level. For alti- tudes over 2000 m, contact ABB. Output derated above 1000 m (3281 ft).	-	-
Air temperature	0 ... +40 °C (+32 ... +104 °F). No con- densation allowed. Output derated in the range +40 ... +50 °C (+104 ... +122 °F).	-40 to +70 °C (-40 to +158 °F)	-40 to +70 °C (-40 to +158 °F)

	Operation installed for stationary use	Storage in the protective package	Transportation in the protective package
Relative humidity	Max. 95%	Max. 95%	Max. 95%
	No condensation allowed. Maximum allowed relative humidity is 60% in the presence of corrosive gases.		
Contamination	IEC/EN 60721-3-3:2002: Classification of environmental conditions - Part 3-3: Classification of groups of environmental parameters and their severities - Stationary use of weather protected locations Chemical gases: Class 3C2 Solid particles: Class 3S2 (3S1 with IP20). No conductive dust allowed.	IEC 60721-3-1:1997 Chemical gases: Class 1C2 Solid particles: Class 1S3 (packing must support this, otherwise 1S2)	IEC 60721-3-2:1997 Chemical gases: Class 2C2 Solid particles: Class 2S2
Pollution degree	2		
Vibration IEC/EN 61800-5-1 IEC 60068-2-6:2007, EN 60068-2-6:2008 Environmental testing Part 2: Tests –Test Fc: Vibration (sinusoidal)	IEC/EN 60721-3-3:2002 10...57 Hz: max. 0.075 mm amplitude 57...150 Hz: 1 g Units with marine construction (option +C121): Max. 1 mm (0.04 in) (5 ... 13.2 Hz), max. 0.7 g (13.2 ... 100 Hz) sinusoidal	IEC/EN 60721-3-1:1997 10...57 Hz: max. 0.075 mm amplitude 57...150 Hz: 1 g	IEC/EN 60721-3-2:1997 2...9 Hz: max. 3.5 mm amplitude 9...200 Hz: 10 m/s ² (32.8 ft/s ²)
Shock IEC 60068-2-27:2008, EN 60068-2-27:2009 Environmental testing - Part 2-27: Tests - Test Ea and guidance: Shock	Not allowed	With packing max. 100 m/s ² (328 ft/s ²) 11 ms	With packing max. 100 m/s ² (328 ft/s ²) 11 ms

Auxiliary circuit power consumption

Cabinet heater and cabinet lighting (options +G300 and +G301)	100 W
External uninterruptible power supply (option +G307)	150 W
Motor heater (option +G313)	According to the heater type

Materials

■ Cabinet

Enclosure	Zinc coated steel sheet
-----------	-------------------------

Finish	Polyester thermosetting powder coating on visible surfaces, color RAL Classic 7035 and RAL Classic 9017
Busbars for user power connections	Tin-plated copper
Fire safety of materials (IEC 60332-1)	Insulating materials and non-metallic items: mostly self-extinctive

■ Package

Standard package (Container package) Vertical	<p>Materials: Wood, PE (VCI film), VCI emitter, clay desiccant, PE sheet, PET strap, metal fixing clamps and screw, packing tape.</p> <p>Transport method: Road and air transport and sea transport in container.</p> <p>Storage conditions (IEC 60721-3-1): Up to 24 months (1K20) in enclosed conditions, up to 3 months in sheltered conditions (1K23, 1K24).</p>
Seaworthy package (option +P912) Vertical	<p>Drive widths over 830 mm with seaworthy packing option +P912 are delivered in a vertical package.</p> <p>Materials: Wood, plywood, PE (VCI film), VCI emitter, clay desiccant, PE sheet, metal fixing clamps and screw, packing tape.</p> <p>Transport method: Road and air transport and sea transport in container or deck.</p> <p>Storage conditions (IEC 60721-3-1): Up to 24 months (1K20) in enclosed conditions, up to 12 months in sheltered conditions (1K23, 1K24) and up to 3 months in open-air conditions (1K25–1K27).</p>
Seaworthy package (option +P912) Horizontal, Corrugated cardboard	<p>Drive widths up to 830 mm with seaworthy packing option +P912 are delivered in a horizontal package. Default package is corrugated cardboard.</p> <p>Materials: Wood, PE (VCI film), VCI emitter, clay desiccant, PET strap, metal fixing clamps and screw, packing tape.</p> <p>Transport method: Road, rail and air transport and sea transport in container.</p> <p>Storage conditions (IEC 60721-3-1): Up to 24 months (1K20) in enclosed conditions, up to 6 months in sheltered conditions (1K23, 1K24).</p>
Seaworthy package (option +P912) Horizontal, Plywood	<p>Drive widths up to 830 mm with seaworthy packing option +P912 are delivered in a horizontal package. Plywood package on special request only.</p> <p>Materials: Wood, plywood, PE (VCI film), VCI emitter, clay desiccant, metal fixing clamps and screw, packing tape.</p> <p>Transport method: Road, rail and air transport and sea transport in container or deck.</p> <p>Storage conditions (IEC 60721-3-1): Up to 24 months (1K20) in enclosed conditions, up to 6 months in sheltered conditions (1K23, 1K24) and up to 3 months in open-air conditions (1K25–1K27).</p>

Disposal

The main parts of the drive can be recycled to preserve natural resources and energy. Product parts and materials should be dismantled and separated.

Generally all metals, such as steel, aluminum, copper and its alloys, and precious metals can be recycled as material. Plastics, rubber, cardboard and other packaging material can be used in energy recovery. Printed circuit boards and large electrolytic capacitors need selective treatment according to IEC 62635 guidelines. To aid recycling, plastic parts are marked with an appropriate identification code.



Contact your local ABB distributor for further information on environmental aspects and recycling instructions for professional recyclers. End of life treatment must follow international and local regulations. See *ACS880 cabinet-installed drives recycling instructions and environmental information* (3AXD50000153909 [English]).







Applicable standards

The drive complies with the standards below. The compliance with the European Low Voltage Directive is verified according to standard EN 61800-5-1.

IEC/EN 61800-5-1:2007	<i>Adjustable speed electrical power drive systems. Part 5-1: Safety requirements– electrical, thermal and energy</i>
IEC 60146-1-1:2009 EN 60146-1-1:2010	<i>Semiconductor converters – General requirements and line commutated converters – Part 1-1: Specification of basic requirements</i>
IEC 60529:1989 EN 60529:1991	<i>Degrees of protection provided by enclosures (IP code).</i>
IEC 60204-1:2005 + A1:2008 EN 60204-1:2006 + AC:2010	<i>Safety of machinery. Electrical equipment of machines. Part 1: General requirements.</i>
IEC/EN 61800-3:2004	<i>Adjustable speed electrical power drive systems. Part 3: EMC requirements and specific test methods</i>
UL 50E 1st Edition:2007	<i>Enclosures for Electrical Equipment, Environmental considerations</i>
UL 508A 2nd Edition:2013	<i>Industrial Control Panels</i>
UL 50 12th Edition:2007	<i>Enclosures for Electrical Equipment, Non-Environmental Considerations</i>
CSA C22.2 No. 14- 18:2013	<i>Industrial control equipment</i>
CSA C22.2 No. 94.2-07	<i>Enclosures for electrical equipment, environmental considerations</i>

Markings

	CE mark Product complies with the applicable European Union legislation. For fulfilling the EMC requirements, see the additional information concerning the drive EMC compliance (IEC/EN 61800-3).
	UL Listed mark for USA and Canada Product has been tested and evaluated against the relevant North American standards by the Underwriters Laboratories. Valid with rated voltages up to 600 V.

	<p>TÜV Safety Approved mark (functional safety) Product contains Safe Torque Off and possibly other (optional) safety functions which are certified by TÜV according to the relevant functional safety standards. Applicable to drives and inverters; not applicable to supply, brake or DC/DC converter units or modules.</p>
	<p>CSA certification mark for USA and Canada Product has been tested and evaluated against the relevant North American standards by the CSA Group. Valid with rated voltages up to 600 V.</p>
	<p>EAC (Eurasian Conformity) mark Product complies with the technical regulations of the Eurasian Customs Union. EAC mark is required in Russia, Belarus and Kazakhstan.</p>
	<p>Electronic Information Products (EIP) green mark The product complies with <i>the People's Republic of China Electronic Industry Standard</i> (SJ/T 11364-2014). The product does not contain toxic and hazardous substances or elements above the maximum concentration values, and it is an environmentally-friendly product which can be recycled.</p>
	<p>RCM mark Product complies with Australian and New Zealand requirements specific to EMC, telecommunications and electrical safety. For fulfilling the EMC requirements, see the additional information concerning the drive EMC compliance (IEC/EN 61800-3).</p>
	<p>KC mark Product complies with Korea's product safety requirements for electrical and electronic equipment and components that utilize power from 50...1000 V AC.</p>
	<p>WEEE mark At the end of life the product should enter the recycling system at an appropriate collection point and not placed in the normal waste stream.</p>

CE marking

A CE mark is attached to the drive to verify that the drive complies with the provisions of the European Low Voltage and EMC Directives. The CE marking also verifies that the drive, in regard to its safety functions (such as Safe torque off), conforms with the Machinery Directive as a safety component.

■ Compliance with the European Low Voltage Directive

The compliance with the European Low Voltage Directive has been verified according to standard EN 61800-5-1.

■ Compliance with the European EMC Directive

The EMC Directive defines the requirements for immunity and emissions of electrical equipment used within the European Union. The EMC product standard (EN 61800- 3:2004) covers requirements stated for drives. See section [Compliance with the EN 61800-3:2004](#) below.

Compliance with the EN 61800-3:2004

■ Definitions

EMC stands for Electromagnetic Compatibility. It is the ability of electrical/electronic equipment to operate without problems within an electromagnetic environment. Likewise, the equipment must not disturb or interfere with any other product or system within its locality.

First environment includes establishments connected to a low-voltage network which supplies buildings used for domestic purposes.

Second environment includes establishments connected to a network not supplying domestic premises.

Drive of category C1: drive of rated voltage less than 1000 V and intended for use in the first environment.

Drive of category C2: drive of rated voltage less than 1000 V and intended to be installed and started up only by a professional when used in the first environment.

Note: A professional is a person or organization having necessary skills in installing and/or starting up power drive systems, including their EMC aspects.

Drive of category C3: drive of rated voltage less than 1000 V and intended for use in the second environment and not intended for use in the first environment.

Drive of category C4: drive of rated voltage equal to or above 1000 V, or rated current equal to or above 400 A, or intended for use in complex systems in the second environment.

■ Category C2

The drive complies with the standard with the following provisions:

1. The drive is equipped with EMC filter (option +E202).
2. The motor and control cables are selected as specified in the hardware manual.
3. The drive is installed according to the instructions given in the hardware manual.
4. Maximum motor cable length is 150 meters (492 ft) for frames R6 to R9 and 100 meters (328 ft) for frames R10 and R11.



WARNING!

The drive may cause radio interference if used in a residential or domestic environment. The user is required to take measures to prevent interference, in addition to the requirements for CE compliance listed above, if necessary.

Note: Do not install a drive equipped with EMC filter +E202/ARFI-10 on IT (ungrounded) systems. The supply network becomes connected to ground potential through the EMC filter capacitors which may cause danger or damage to the unit.

■ Category C3

The drive complies with the standard with the following provisions:

1. The drive is equipped with EMC filter +E200, +E201 or +E210.
 2. The input power cables, motor cables and control cables are selected as specified in the appropriate drive manual(s).
-

3. The drive is installed according to the instructions given in the appropriate drive manual(s).
4. Maximum motor cable length is 150 meters (492 ft) for frames R6 to R9 and 100 meters (328 ft) for frames R10 and R11.



WARNING!

A drive of category C3 is not intended to be used on a low-voltage public network which supplies domestic premises. Radio frequency interference is expected if the drive is used on such a network.

■ **Category C4**

The drive complies with the C4 category with these provisions:

1. It is ensured that no excessive emission is propagated to neighboring low-voltage networks. In some cases, the natural suppression in transformers and cables is sufficient. If in doubt, the supply transformer with static screening between the primary and secondary windings can be used.

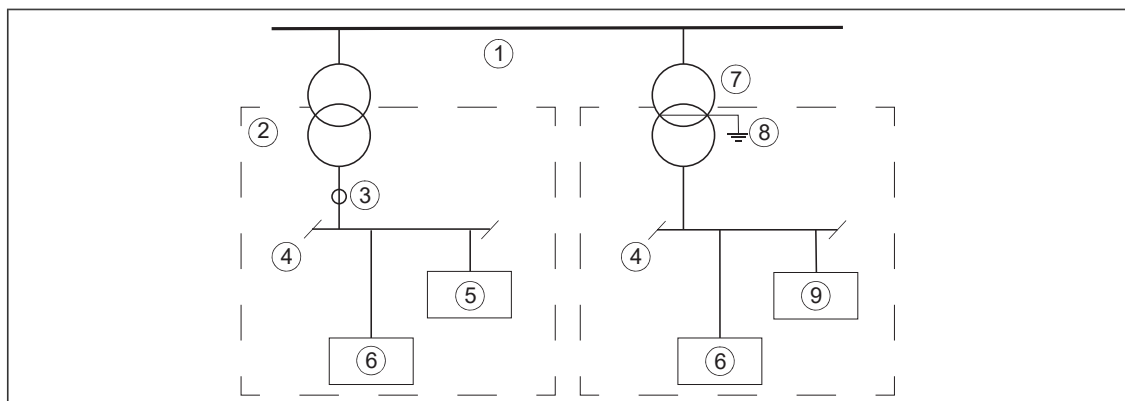

1	Medium voltage network	6	Equipment
2	Neighboring network	7	Supply transformer
3	Point of measurement	8	Static screen
4	Low voltage	9	Drive
5	Equipment (victim)	-	-

2. An EMC plan for preventing disturbances is drawn up for the installation. A template is available in *Technical guide No. 3 EMC compliant installation and configuration for a power drive system* ([3AFE61348280](#) (English)).
3. The motor and control cables are selected, and routed according to the electrical planning guidelines of the drive. The EMC recommendations are obeyed.
4. The drive is installed according to its installation instructions. The EMC recommendations are obeyed.



WARNING!

A drive of category C4 is not intended to be used on a low-voltage public network which supplies domestic premises. Radio frequency interference is expected if the drive is used on such a network.

UL and CSA checklist



WARNING!

Operation of this drive requires detailed installation and operation instructions provided in the hardware and software manuals. The manuals are provided in electronic format in the drive package or on the Internet. Keep the manuals with the drive at all times. Hard copies of the manuals can be ordered through the manufacturer.

- Make sure that the drive type designation label includes the applicable marking.
 - **DANGER - Risk of electric shock.** After disconnecting the input power, always wait for 5 minutes to let the intermediate circuit capacitors discharge before you start working on the drive, motor or motor cable.
 - The drive is to be used in a heated, indoor controlled environment. The drive must be installed in clean air according to the enclosure classification. Cooling air must be clean, free from corrosive materials and electrically conductive dust.
 - The maximum surrounding air temperature is 40 °C at rated output current. The output current is derated for 40 ... 50 °C.
 - The drive is suitable for use in a circuit capable of delivering not more than 100 kA rms symmetrical amperes, 600 V maximum when protected by the UL fuses given elsewhere in this chapter.
 - The cables located within the motor circuit must be rated for at least 75 °C in UL-compliant installations.
 - The input cable must be protected with fuses or circuit breakers. These protective devices provide branch circuit protection in accordance with the national regulations (National Electrical Code (NEC) or Canadian Electrical Code). Obey also any other applicable local or provincial codes.
-



WARNING!

The opening of the branch-circuit protective device may be an indication that a fault current has been interrupted. To reduce the risk of fire or electric shock, current-carrying parts and other components of the device should be examined and replaced if damaged.

- The drive is equipped with UL listed fuses which provide branch circuit protection in accordance with the National Electrical Code (NEC) and Canadian Electrical Code. The fuses are listed elsewhere in this chapter.
- The drive provides motor overload protection. This feature is not enabled when the drives leaves the ABB factory. For enabling this motor overload protection, see the firmware manual.
- The drive overvoltage category according to IEC 60664-1 is III, except for auxiliary power connections (fan, control, heating, lighting, cooling unit pump etc) which are of category II.

Tightening torques

Unless a tightening torque is specified in the text, the following torques can be used.

■ **Electrical connections**

Size	Torque	Strength class
M3	0.5 N·m (4.4 lbf·in)	4.6...8.8
M4	1 N·m (9 lbf·in)	4.6...8.8
M5	4 N·m (35 lbf·in)	8.8
M6	9 N·m (6.6 lbf·ft)	8.8
M8	22 N·m (16 lbf·ft)	8.8
M10	42 N·m (31 lbf·ft)	8.8
M12	70 N·m (52 lbf·ft)	8.8
M16	120 N·m (90 lbf·ft)	8.8

■ **Mechanical connections**

Size	Max. torque	Strength class
M5	6 N·m (53 lbf·in)	8.8
M6	10 N·m (7.4 lbf·ft)	8.8
M8	24 N·m (17.7 lbf·ft)	8.8

■ **Insulation supports**

Size	Max. torque	Strength class
M6	5 N·m (44 lbf·in)	8.8
M8	9 N·m (6.6 lbf·ft)	8.8
M10	18 N·m (13.3 lbf·ft)	8.8
M12	31 N·m (23 lbf·ft)	8.8

■ **Cable lugs**

Size	Max. torque	Strength class
M8	15 N·m (11 lbf·ft)	8.8
M10	32 N·m (23.5 lbf·ft)	8.8
M12	50 N·m (37 lbf·ft)	8.8

Disclaimers

■ **Generic disclaimer**

The manufacturer shall have no obligation with respect to any product which (i) has been improperly repaired or altered; (ii) has been subjected to misuse, negligence or accident; (iii) has been used in a manner contrary to the manufacturer's instructions; or (iv) has failed as a result of ordinary wear and tear.

■ **Cybersecurity disclaimer**

This product is designed to be connected to and to communicate information and data via a network interface. It is Customer's sole responsibility to provide and continuously ensure a secure connection between the product and Customer network or any other network (as the case may be). Customer shall establish and maintain any appropriate measures (such as but not limited to the installation of firewalls, application of authentication measures, encryption of data, installation of anti-virus programs, etc) to protect the product, the network, its system and the interface against any kind of security breaches, unauthorized access, interference, intrusion, leakage and/or theft of data or information. ABB and its affiliates are not liable for damages and/or losses related to such security breaches, any unauthorized access, interference, intrusion, leakage and/or theft of data or information.



Dimension drawings

Example dimension drawings are shown below.

Frames R6 to R8 (IP22, IP42 [+B054], UL Type 1) – with and without options +C129, +H350, +H352

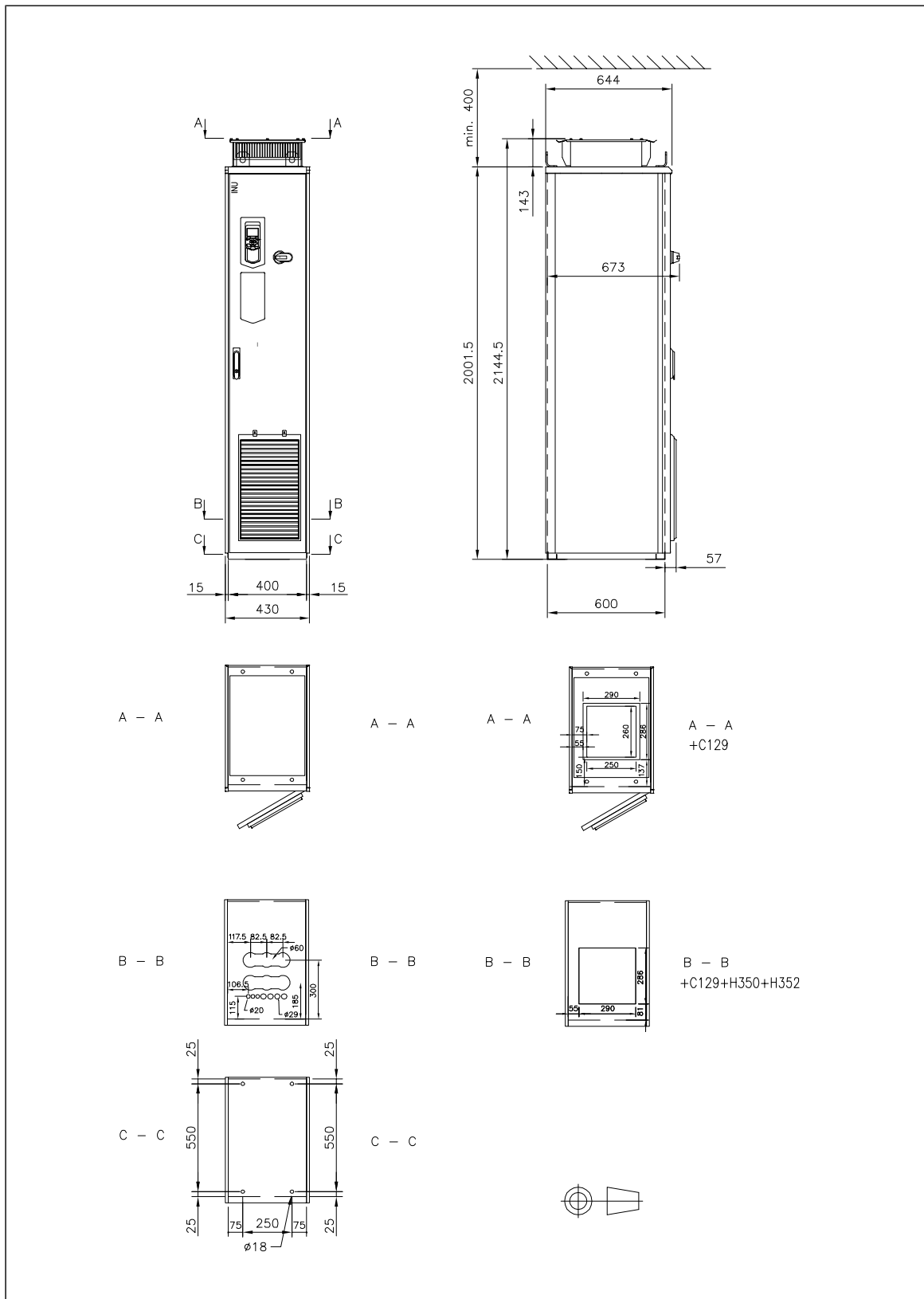

Frames R6 to R8 (IP54 / UL Type 12 [+B055]) – with and without options +C129, +H350, +H352

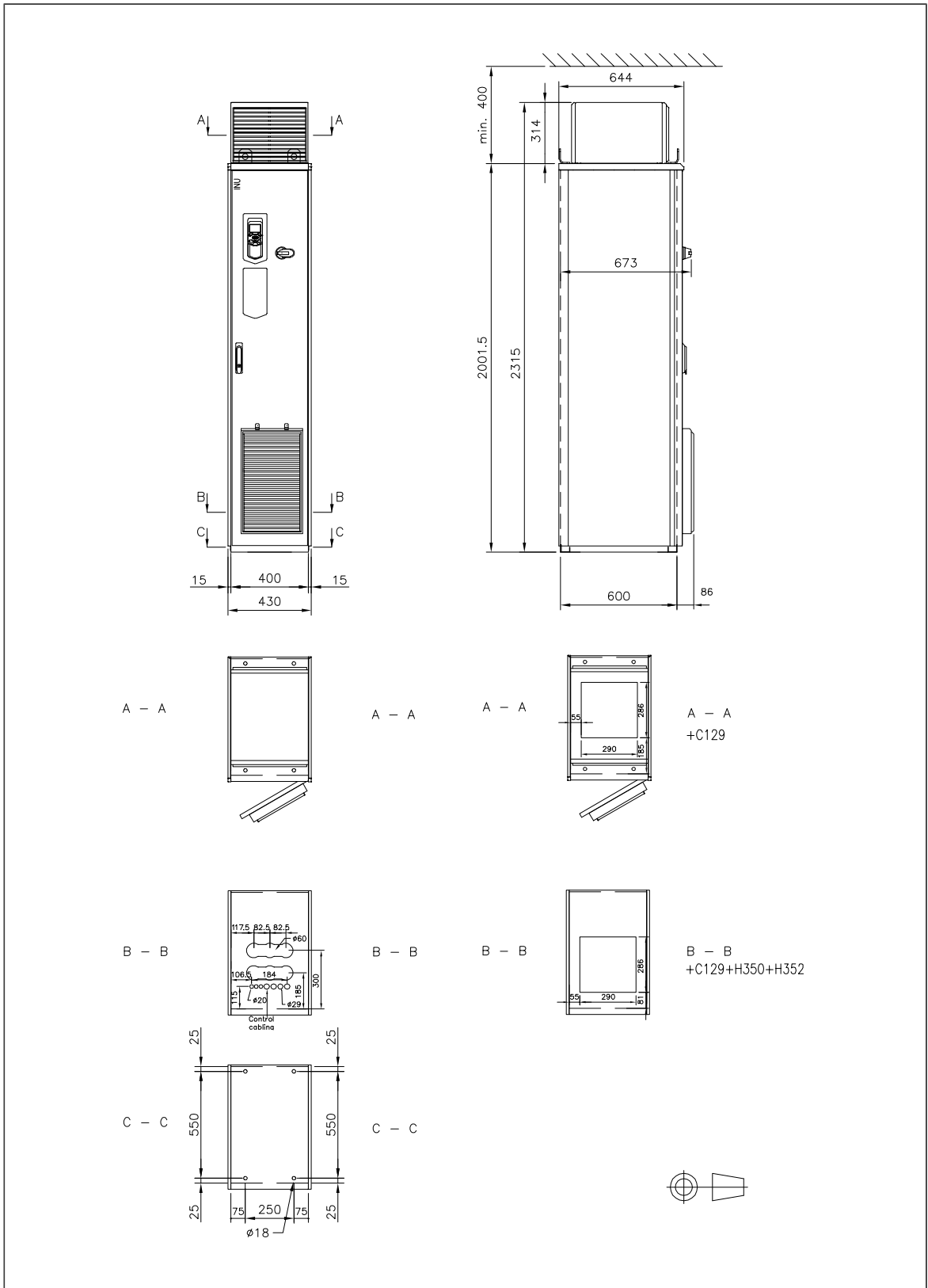

Frame R9 (IP22 and IP42 [+B054], UL Type 1) – with and without options +C129, +H350, +H352

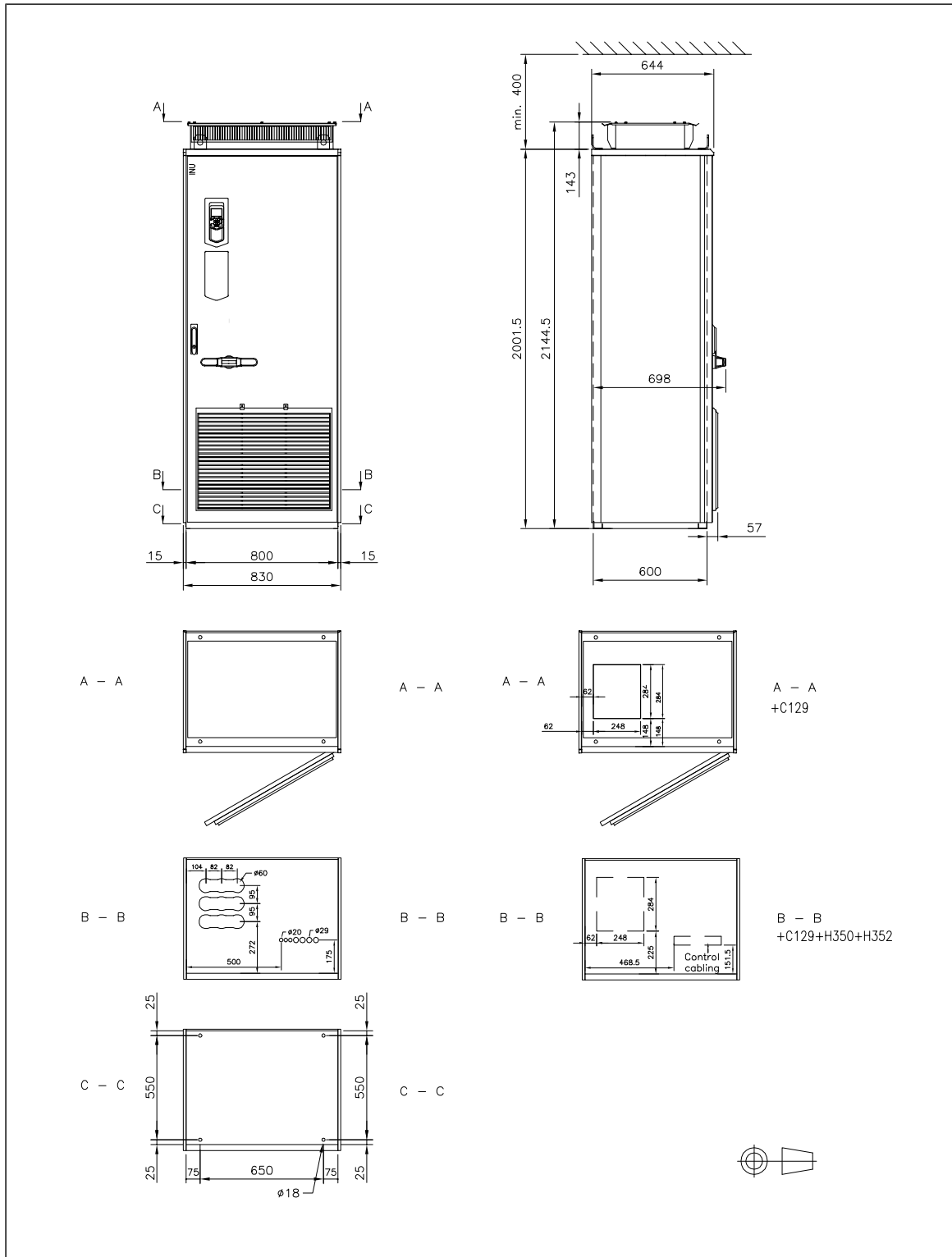

Frame R9 (IP54 / UL Type 12 [+B055]) – with and without options +C129, +H350, +H352

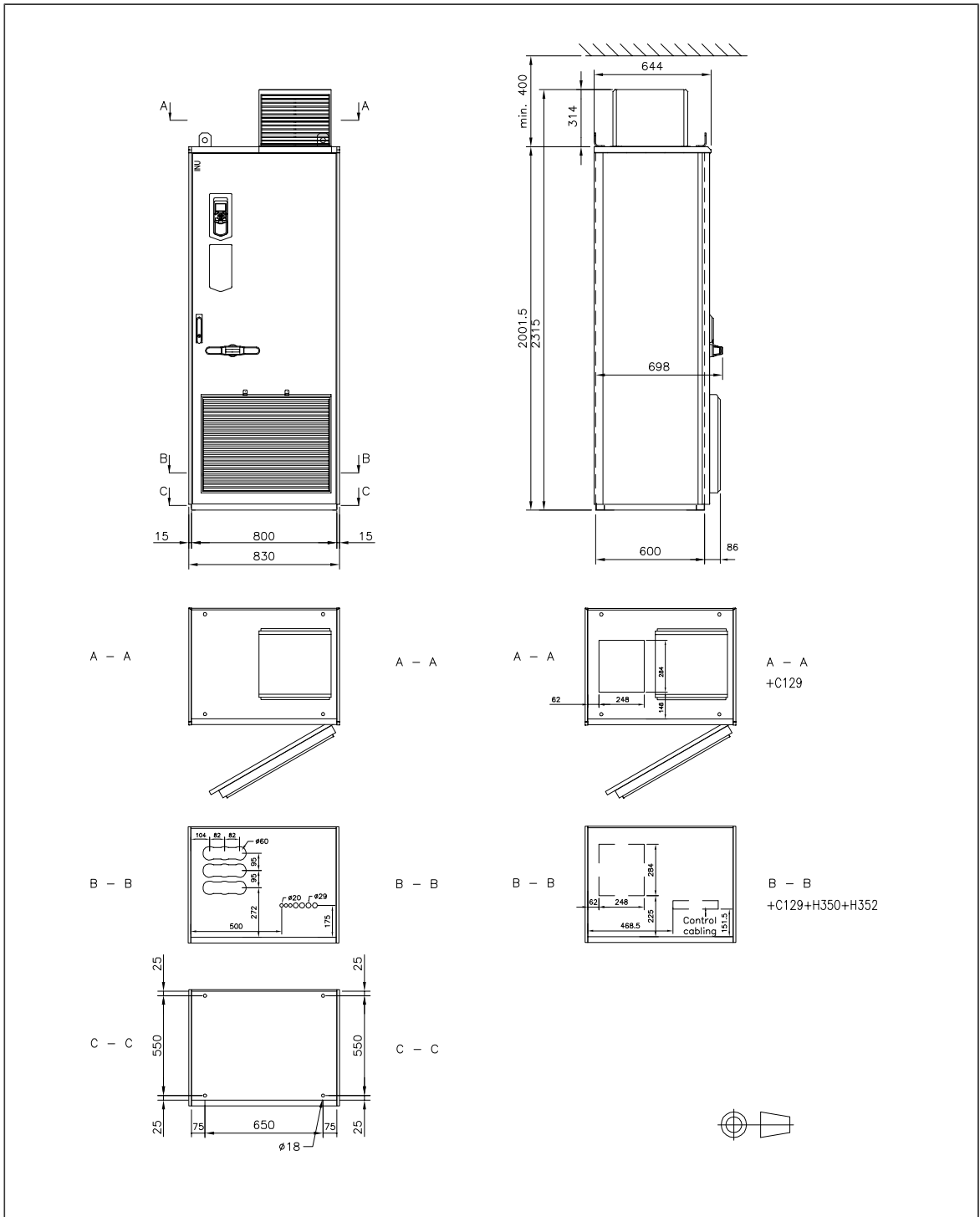

Frame R9 marine (IP22, IP42 [+B054], UL Type 1) – option +C121)

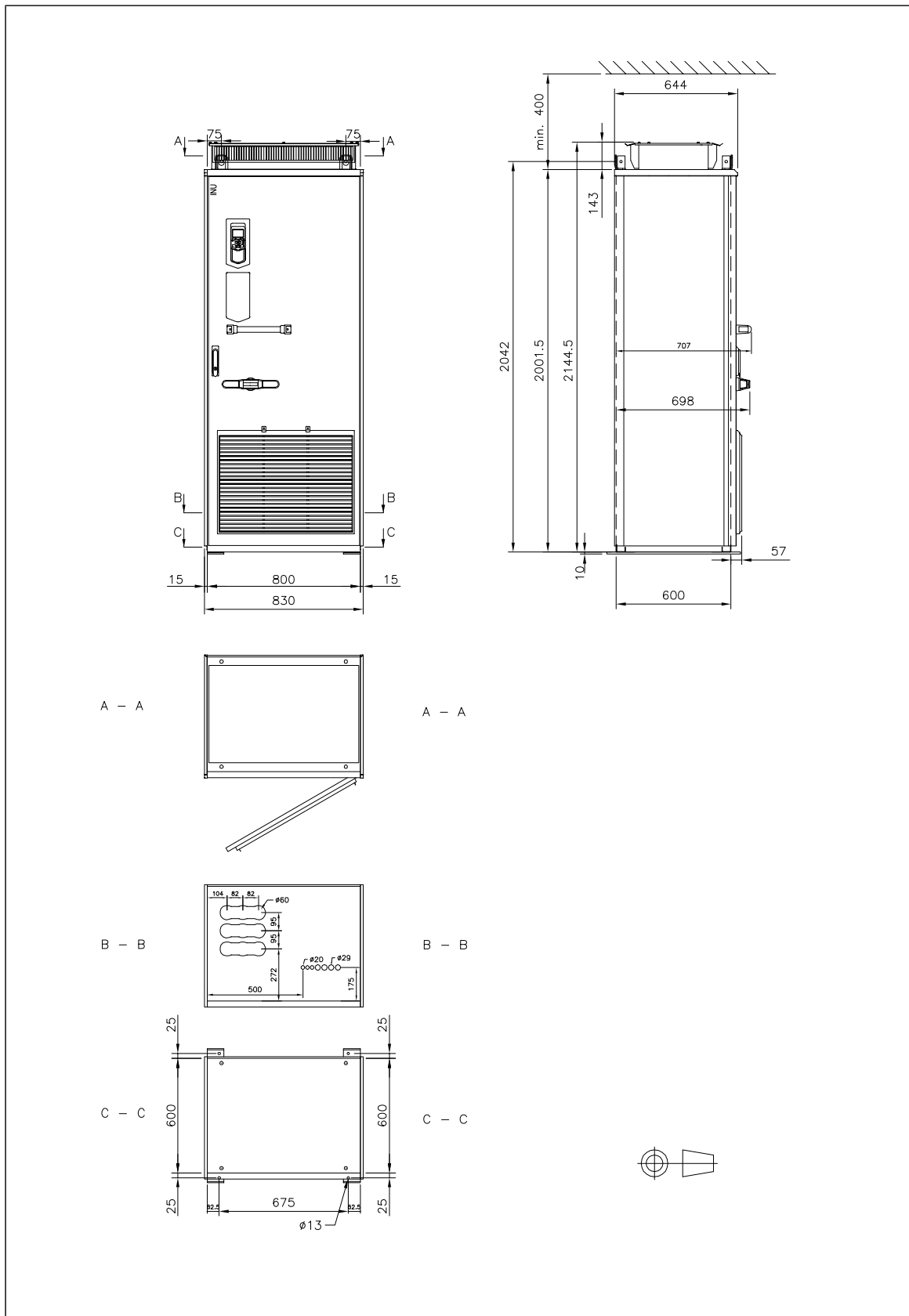

Frames R6 to R8 with options +F289, +C129 with and without +H350, +H352 (UL Type 1)

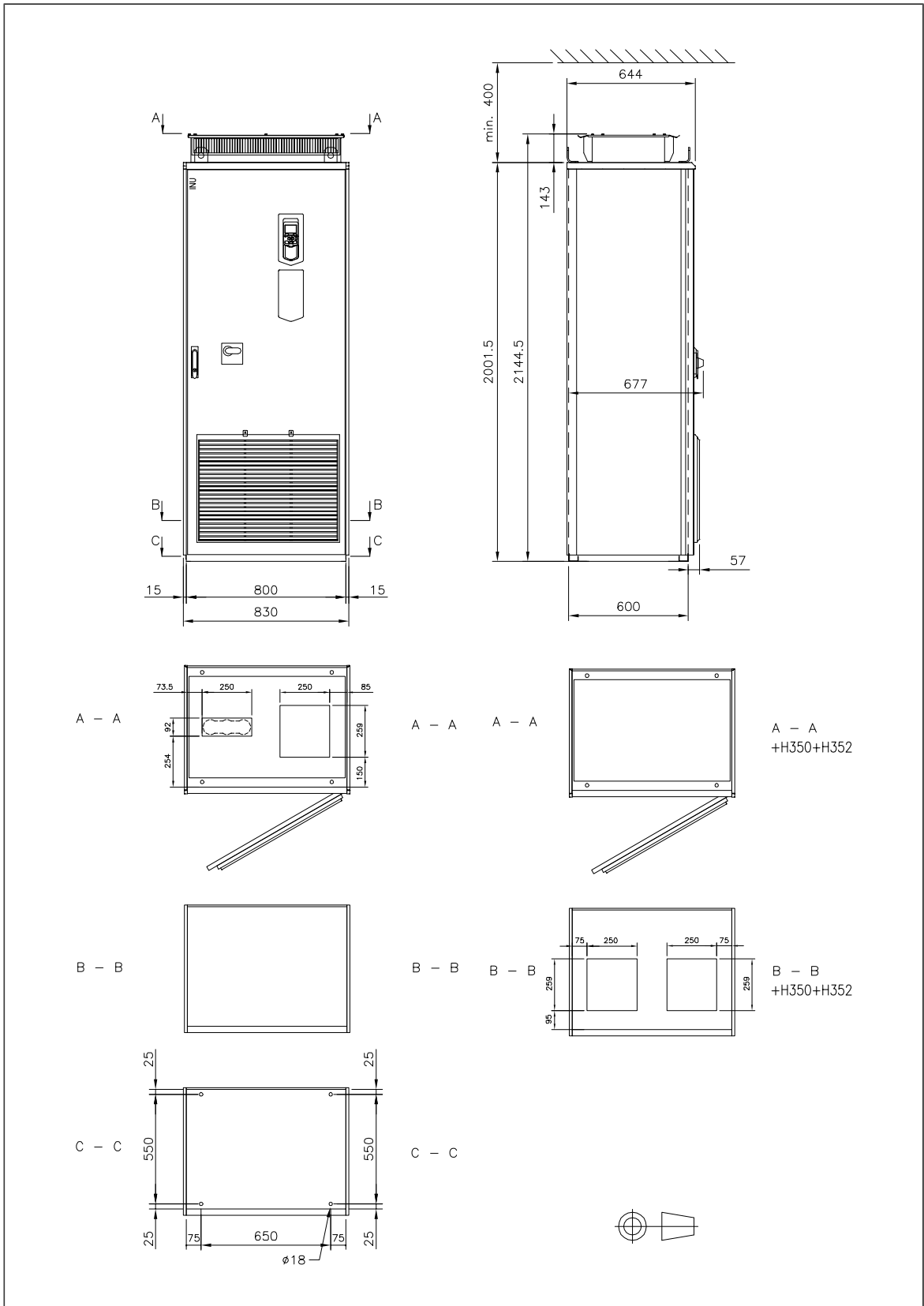

Frames R6 to R8 with options +F289, +C129, with and without +H350, +H352 (UL Type 12 [+B055])

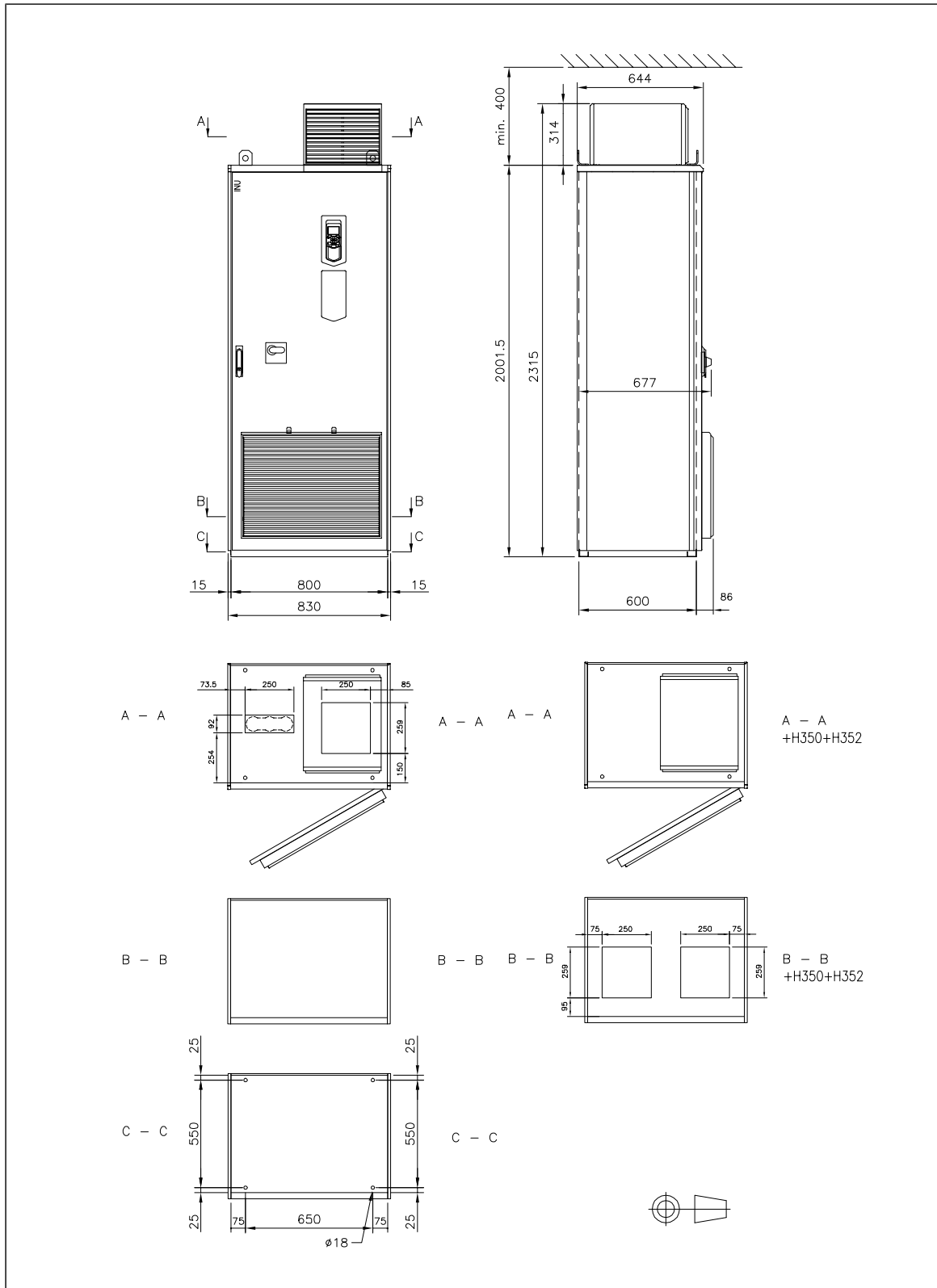

Frames R10 and R11 (IP22, IP42 [+B054], UL Type 1) – with and without options +C129, +H350, +H352

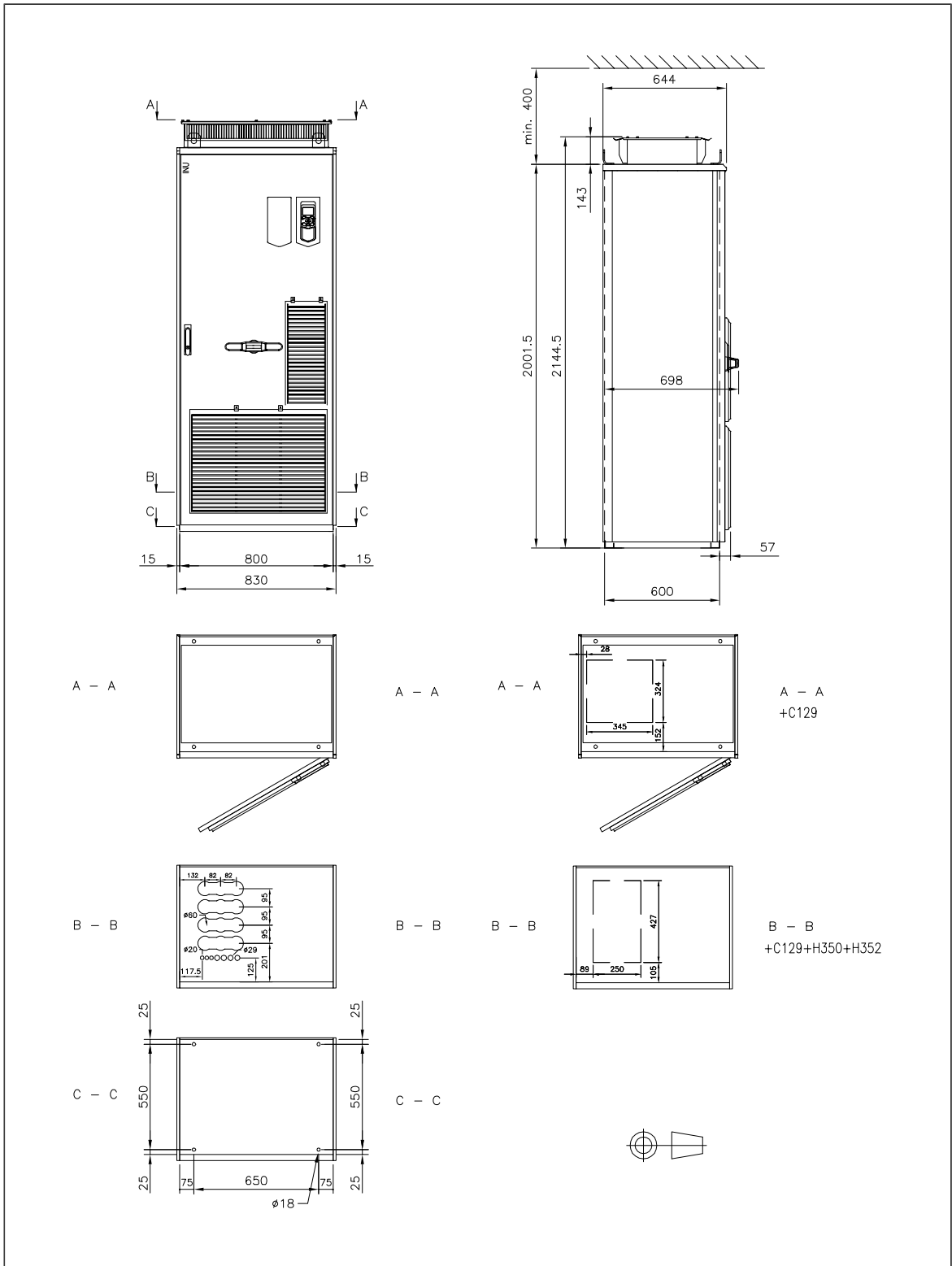

Frames R10 and R11 (IP54 / UL Type 12) – with and without options +C129, +H350, +H352

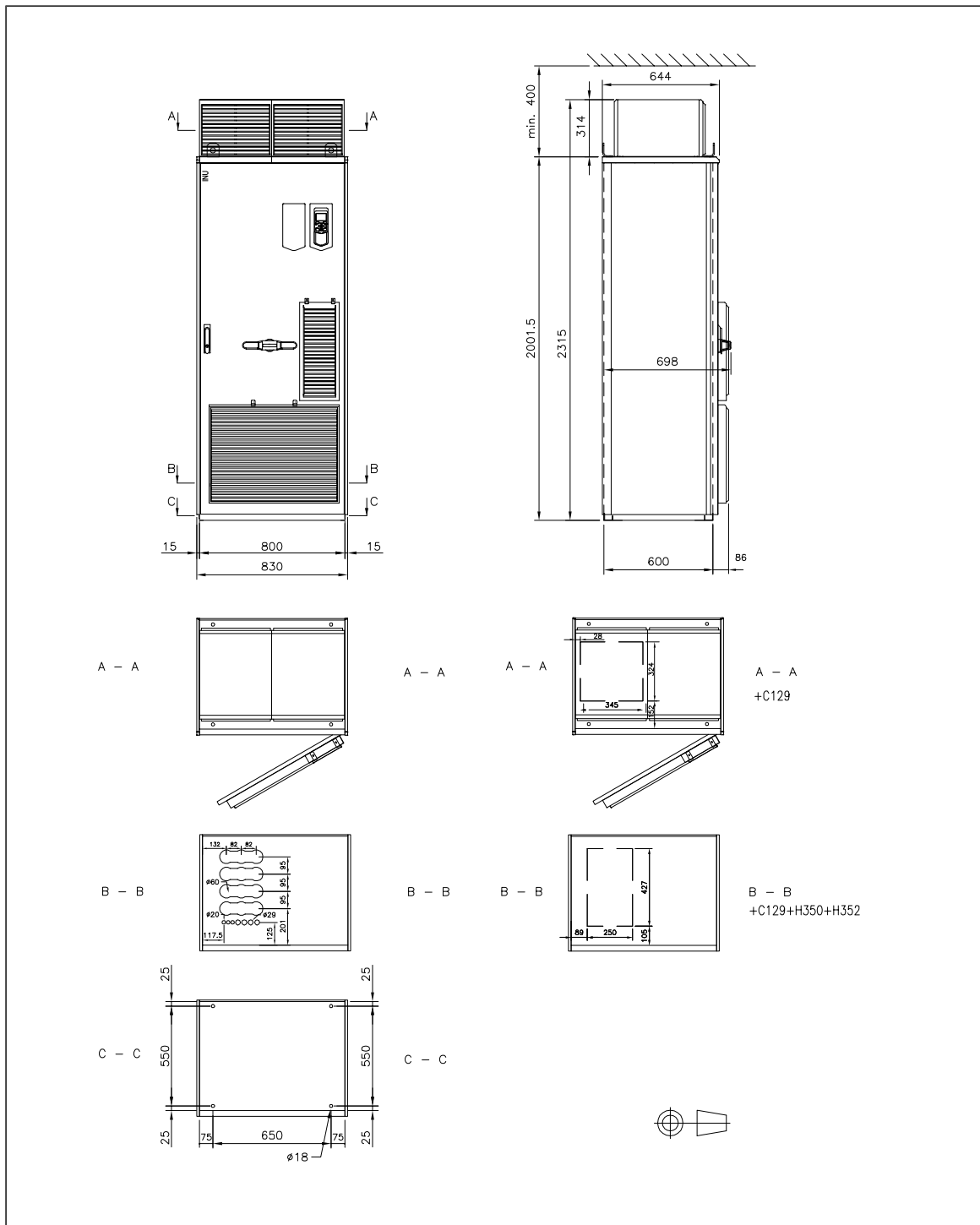

14

The Safe torque off function

Contents of this chapter

This chapter describes the Safe torque off (STO) function of the drive and gives instructions for its use.

Description



WARNING!

In case of parallel-connected drives or dual-winding motors, the STO must be activated on each drive to remove the torque from the motor.

The Safe torque off function can be used, for example, as the final actuator device of safety circuits that stop the drive in case of danger (such as an emergency stop circuit). Another typical application is a prevention of unexpected start-up function that enables short-time maintenance operations like cleaning or work on non-electrical parts of the machinery without switching off the power supply to the drive.

When activated, the Safe torque off function disables the control voltage of the power semiconductors of the drive output stage (A, see the diagrams below), thus preventing the drive from generating the torque required to rotate the motor. If the motor is running when Safe torque off is activated, it coasts to a stop.

The Safe torque off function has a redundant architecture, that is, both channels must be used in the safety function implementation. The safety data given in this manual is calculated for redundant use, and does not apply if both channels are not used.

The Safe torque off function complies with these standards:

Standard	Name
IEC 60204-1:2016 EN 60204-1:2018	<i>Safety of machinery – Electrical equipment of machines – Part 1: General requirements</i>

Standard	Name
IEC 61000-6-7:2014	<i>Electromagnetic compatibility (EMC) – Part 6-7: Generic standards – Immunity requirements for equipment intended to perform functions in a safety-related system (functional safety) in industrial locations</i>
IEC 61326-3-1:2017	<i>Electrical equipment for measurement, control and laboratory use – EMC requirements – Part 3-1: Immunity requirements for safety-related systems and for equipment intended to perform safety-related functions (functional safety) – General industrial applications</i>
IEC 61508-1:2010	<i>Functional safety of electrical/electronic/programmable electronic safety-related systems – Part 1: General requirements</i>
IEC 61508-2:2010	<i>Functional safety of electrical/electronic/programmable electronic safety-related systems – Part 2: Requirements for electrical/electronic/programmable electronic safety-related systems</i>
IEC 61511-1:2016	<i>Functional safety – Safety instrumented systems for the process industry sector</i>
IEC 61800-5-2:2016 EN 61800-5-2:2007	<i>Adjustable speed electrical power drive systems – Part 5-2: Safety requirements – Functional</i>
IEC 62061:2005 + A1:2012 + A2:2015 EN 62061:2005 + AC:2010 + A1:2013 + A2:2015	<i>Safety of machinery – Functional safety of safety-related electrical, electronic and programmable electronic control systems</i>
EN ISO 13849-1:2015	<i>Safety of machinery – Safety-related parts of control systems – Part 1: General principles for design</i>
EN ISO 13849-2:2012	<i>Safety of machinery – Safety-related parts of control systems – Part 2: Validation</i>

The function also corresponds to Prevention of unexpected start-up as specified by EN ISO 14118:2018 (ISO 14118:2017), and Uncontrolled stop (stop category 0) as specified in EN/IEC 60204-1.

■ **Compliance with the European Machinery Directive**

See the technical data.

The Declaration of conformity is shown at the end of this chapter.

Wiring

For the electrical specifications of the STO connection, see the technical data of the control unit.

■ Activation switch

In the wiring diagrams, the activation switch has the designation [K]. This represents a component such as a manually operated switch, an emergency stop push button switch, or the contacts of a safety relay or safety PLC.

- In case a manually operated activation switch is used, the switch must be of a type that can be locked out to the open position.
- The contacts of the switch or relay must open/close within 200 ms of each other.
- An FSO-xx safety functions module or an FPTC-0x thermistor protection module can also be used. For more information, see the module documentation.

■ Cable types and lengths

- Double-shielded twisted-pair cable is recommended.
- Maximum cable lengths:
 - 300 m (1000 ft) between activation switch [K] and drive control unit
 - 60 m (200 ft) between multiple drives
 - 60 m (200 ft) between external power supply and first control unit

Note: A short-circuit in the wiring between the switch and an STO terminal causes a dangerous fault. Therefore, it is recommended to use a safety relay (including wiring diagnostics) or a wiring method (shield grounding, channel separation) which reduces or eliminates the risk caused by the short-circuit.

Note: The voltage at the STO input terminals of the control unit must be at least 17 V DC to be interpreted as “1”.

The pulse tolerance of the input channels is 1 ms.

■ Grounding of protective shields

- Ground the shield in the cabling between the activation switch and the control unit at the control unit only.
 - Ground the shield in the cabling between two control units at one control unit only.
-

■ Single ACS880-07 drive, internal power supply

Dual-channel connection

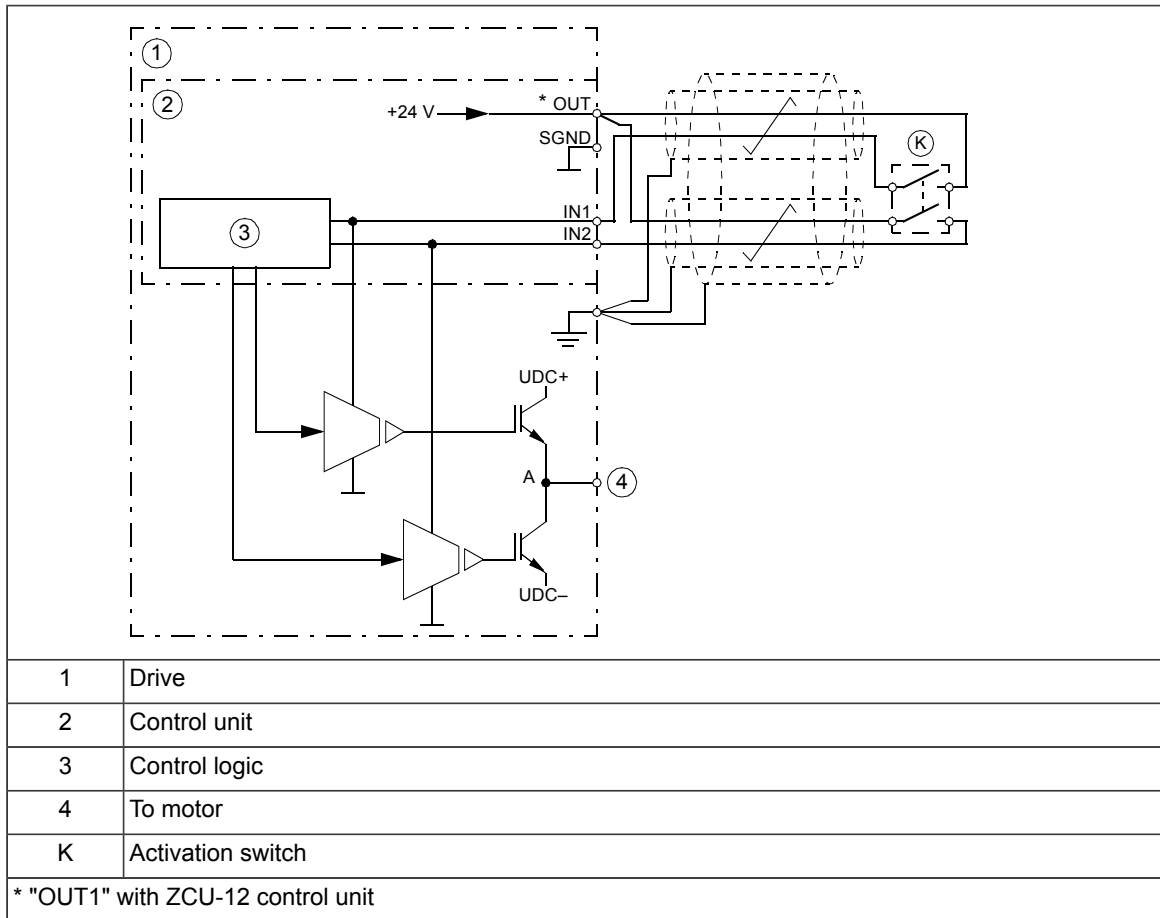

Single-channel connection

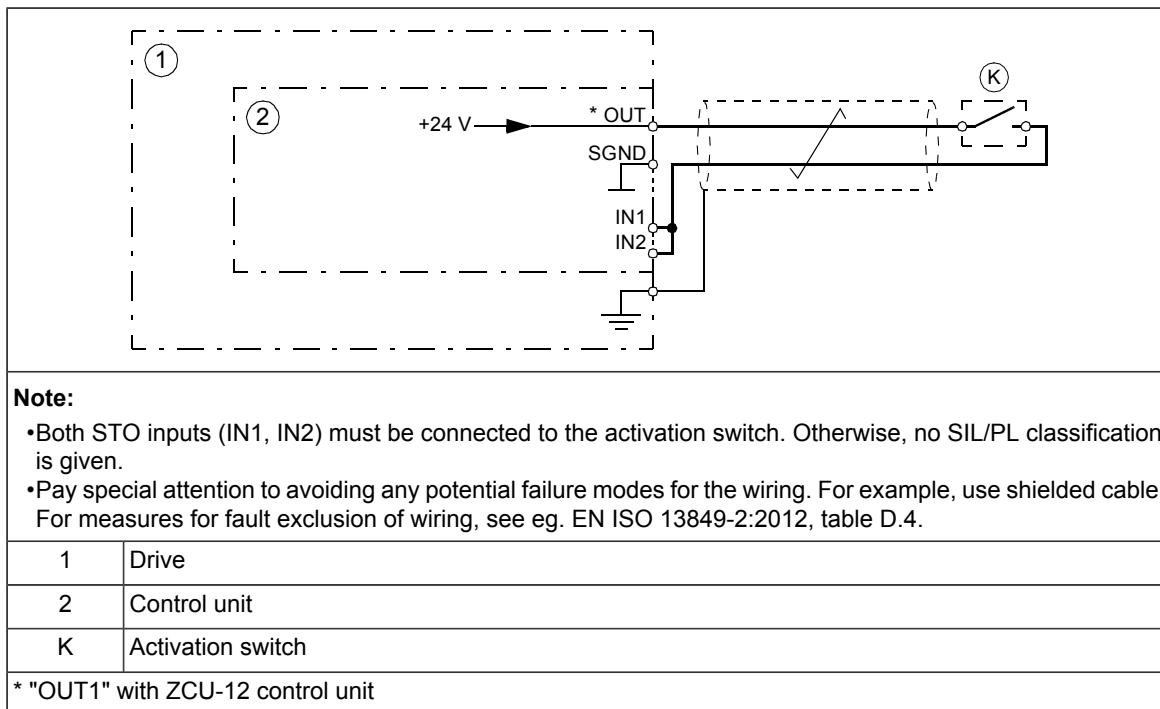

■ Multiple drives

Internal power supply

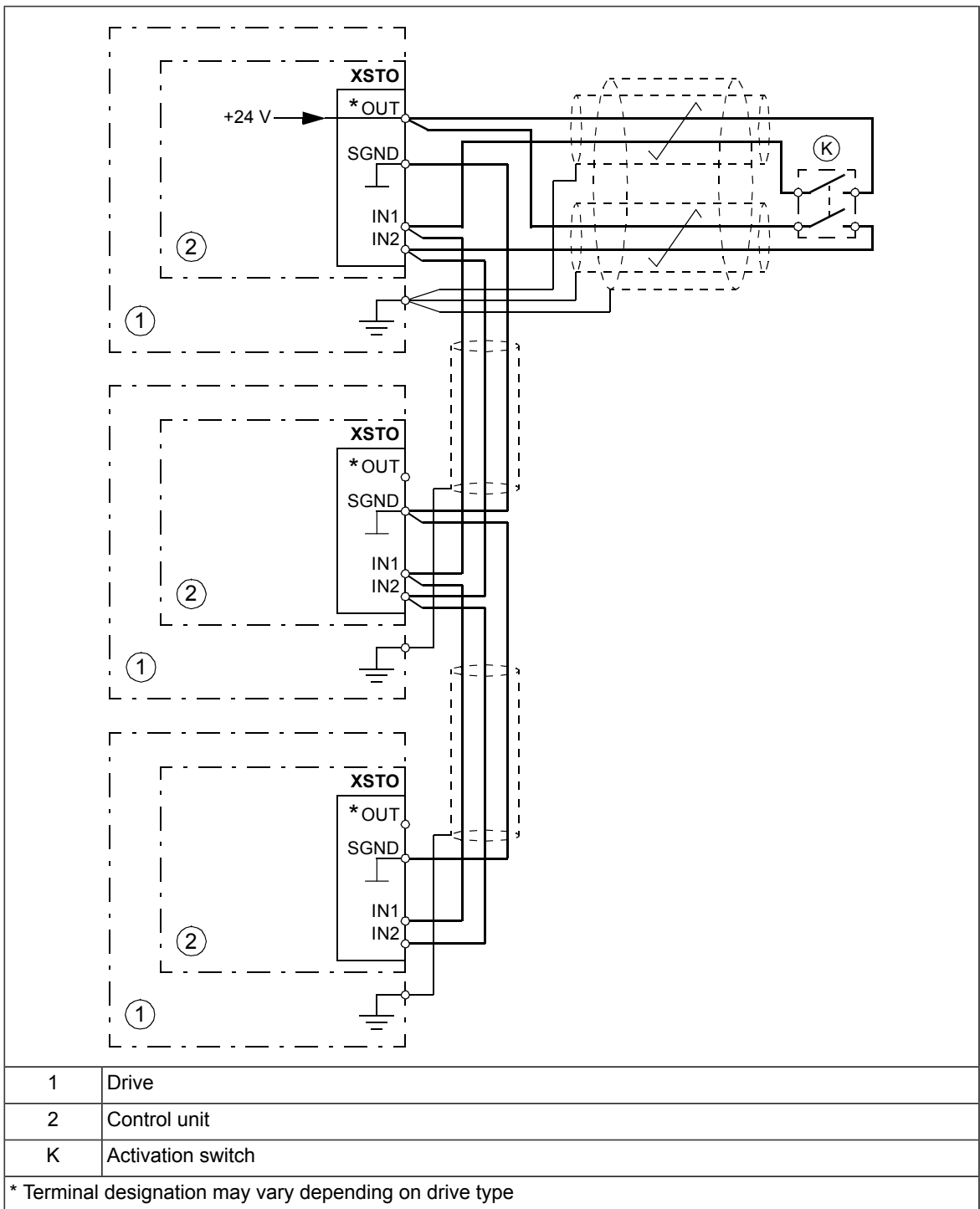

External power supply

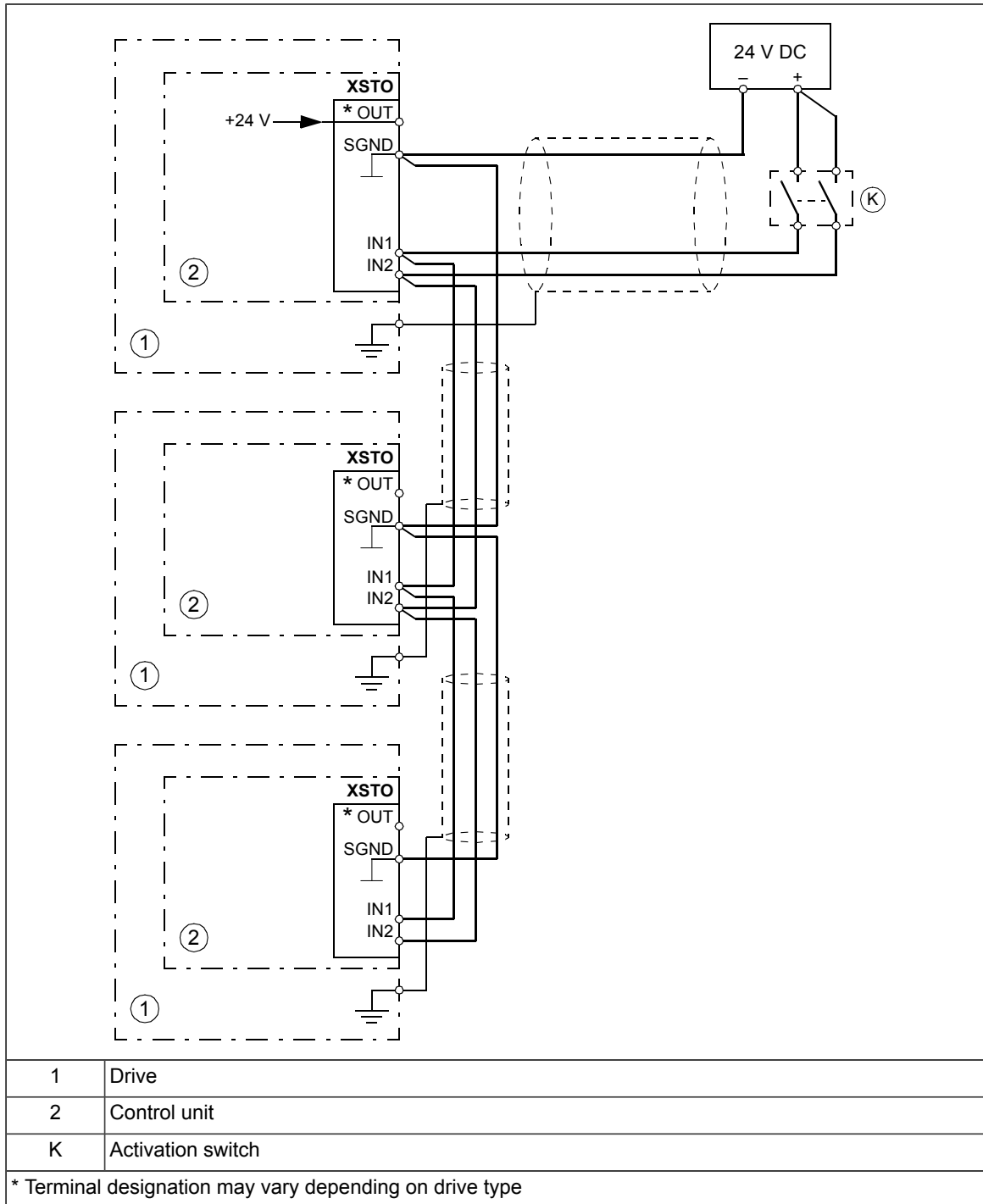

Operation principle

1. The Safe torque off activates (the activation switch is opened, or safety relay contacts open).
2. The STO inputs of the drive control unit de-energize.
3. The control unit cuts off the control voltage from the output IGBTs.
4. The control program generates an indication as defined by parameter 31.22 (see the firmware manual of the drive).

The parameter selects which indications are given when one or both STO signals are switched off or lost. The indications also depend on whether the drive is running or stopped when this occurs.

Note: This parameter does not affect the operation of the STO function itself. The STO function will operate regardless of the setting of this parameter: a running drive will stop upon removal of one or both STO signals, and will not start until both STO signals are restored and all faults reset.

Note: The loss of only one STO signal always generates a fault as it is interpreted as a malfunction of STO hardware or wiring.

5. The motor coasts to a stop (if running). The drive cannot restart while the activation switch or safety relay contacts are open. After the contacts close, a reset may be needed (depending on the setting of parameter 31.22). A new start command is required to start the drive.
-

Start-up including validation test

To ensure the safe operation of a safety function, validation is required. The final assembler of the machine must validate the function by performing a validation test. The test must be performed

- at initial start-up of the safety function
- after any changes related to the safety function (circuit boards, wiring, components, settings, etc.)
- after any maintenance work related to the safety function
- after a drive firmware update.

■ Competence

The validation test of the safety function must be carried out by a competent person with adequate expertise and knowledge of the safety function as well as functional safety, as required by IEC 61508-1 clause 6. The test procedures and report must be documented and signed by this person.

■ Validation test reports

Signed validation test reports must be stored in the logbook of the machine. The report shall include documentation of start-up activities and test results, references to failure reports and resolution of failures. Any new validation tests performed due to changes or maintenance shall be logged into the logbook.

■ Validation test procedure

After wiring the Safe torque off function, validate its operation as follows.

Note: If the drive is equipped with safety option +L536, +L537, +Q950, +Q951, +Q952, +Q957, +Q963, +Q964, +Q978 or +Q979, also do the procedure shown in the documentation of the option.

Action	<input checked="" type="checkbox"/>
 WARNING! Obey the safety instructions. If you ignore them, injury or death, or damage to the equipment can occur.	<input type="checkbox"/>
Make sure that the drive can be run and stopped freely during start-up.	<input type="checkbox"/>
Stop the drive (if running), switch the input power off and isolate the drive from the power line using a disconnecter.	<input type="checkbox"/>
Check the STO circuit connections against the wiring diagram.	<input type="checkbox"/>
Close the disconnecter and switch the power on.	<input type="checkbox"/>
Test the operation of the STO function when the motor is stopped. •Give a stop command for the drive (if running) and wait until the motor shaft is at a standstill. Make sure that the drive operates as follows: •Open the STO circuit. The drive generates an indication if one is defined for the 'stopped' state in parameter 31.22 (see the firmware manual). •Give a start command to verify that the STO function blocks the drive's operation. The drive generates a warning. The motor should not start. •Close the STO circuit. •Reset any active faults. Restart the drive and check that the motor runs normally.	<input type="checkbox"/>

Action	<input checked="" type="checkbox"/>
<p>Test the operation of the STO function when the motor is running.</p> <ul style="list-style-type: none"> • Start the drive and make sure the motor is running. • Open the STO circuit. The motor should stop. The drive generates an indication if one is defined for the 'running' state in parameter 31.22 (see the firmware manual). • Reset any active faults and try to start the drive. • Make sure that the motor stays at a standstill and the drive operates as described above in testing the operation when the motor is stopped. • Close the STO circuit. • Reset any active faults. Restart the drive and check that the motor runs normally. 	<input type="checkbox"/>
<p>Test the operation of the failure detection of the drive. The motor can be stopped or running.</p> <ul style="list-style-type: none"> • Open the 1st channel of the STO circuit. If the motor was running, it should coast to a stop. The drive generates a <i>FA81 Safe Torque Off 1 loss</i> fault indication (see the firmware manual). • Give a start command to verify that the STO function blocks the drive's operation. The motor should not start. • Close the STO circuit. • Reset any active faults. Restart the drive and check that the motor runs normally. • Open the 2nd channel of the STO circuit. If the motor was running, it should coast to a stop. The drive generates a <i>FA82 Safe Torque Off 2 loss</i> fault indication (see the firmware manual). • Give a start command to verify that the STO function blocks the drive's operation. The motor should not start. • Close the STO circuit. • Reset any active faults. Restart the drive and check that the motor runs normally. 	<input type="checkbox"/>
<p>Document and sign the validation test report which verifies that the safety function is safe and accepted for operation.</p>	<input type="checkbox"/>

Use

1. Open the activation switch, or activate the safety functionality that is wired to the STO connection.
2. The STO inputs on the drive control unit de-energize, and the control unit cuts off the control voltage from the output IGBTs.
3. The control program generates an indication as defined by parameter 31.22 (see the firmware manual of the drive).
4. The motor coasts to a stop (if running). The drive will not restart while the activation switch or safety relay contacts are open.
5. Deactivate the STO by closing the activation switch, or resetting the safety functionality that is wired to the STO connection.
6. Reset any faults before restarting.



WARNING!

The Safe torque off function does not disconnect the voltage of the main and auxiliary circuits from the drive. Therefore maintenance work on electrical parts of the drive or the motor can only be carried out after isolating the drive from the supply and all other voltage sources.



WARNING!

The drive cannot detect or memorize any changes in the STO circuitry when the drive control unit is not powered. If both STO circuits are closed and a level-type start signal is active when the power is restored, it is possible that the drive starts without a fresh start command. Take this into account in the risk assessment of the system.



WARNING!

(With permanent magnet or synchronous reluctance [SynRM] motors only)

In case of a multiple IGBT power semiconductor failure, the drive can produce an alignment torque which maximally rotates the motor shaft by $180/p$ degrees (with permanent magnet motors) or $180/2p$ degrees (with synchronous reluctance [SynRM] motors) regardless of the activation of the Safe torque off function. p denotes the number of pole pairs.

Notes:

- If a running drive is stopped by using the Safe torque off function, the drive will cut off the motor supply voltage and the motor will coast to a stop. If this causes danger or is not otherwise acceptable, stop the drive and machinery using the appropriate stop mode before activating the Safe torque off function.
 - The Safe torque off function overrides all other functions of the drive.
 - The Safe torque off function is ineffective against deliberate sabotage or misuse.
 - The Safe torque off function has been designed to reduce the recognized hazardous conditions. In spite of this, it is not always possible to eliminate all potential hazards. The assembler of the machine must inform the final user about the residual risks.
-

Maintenance

After the operation of the circuit is validated at start-up, the STO function shall be maintained by periodic proof testing. In high demand mode of operation, the maximum proof test interval is 20 years. In low demand mode of operation, the maximum proof test interval is 5 or 2 years; see section [Safety data \(page 257\)](#). It is assumed that all dangerous failures of the STO circuit are detected by the proof test. To perform the proof test, do the [Validation test procedure \(page 252\)](#).

Note: See also the Recommendation of Use CNB/M/11.050 (published by the European co-ordination of Notified Bodies) concerning dual-channel safety-related systems with electromechanical outputs:

- When the safety integrity requirement for the safety function is SIL 3 or PL e (cat. 3 or 4), the proof test for the function must be performed at least every month.
- When the safety integrity requirement for the safety function is SIL 2 (HFT = 1) or PL d (cat. 3), the proof test for the function must be performed at least every 12 months.

The STO function of the drive does not contain any electromechanical components.

In addition to proof testing, it is a good practice to check the operation of the function when other maintenance procedures are carried out on the machinery.

Include the Safe torque off operation test described above in the routine maintenance program of the machinery that the drive runs.

If any wiring or component change is needed after start up, or the parameters are restored, do the test given in section [Validation test procedure \(page 252\)](#).

Use only spare parts approved by ABB.

Record all maintenance and proof test activities in the machine logbook.

■ Competence

The maintenance and proof test activities of the safety function must be carried out by a competent person with adequate expertise and knowledge of the safety function as well as functional safety, as required by IEC 61508-1 clause 6.

Fault tracing

The indications given during the normal operation of the Safe torque off function are selected by drive control program parameter 31.22.

The diagnostics of the Safe torque off function cross-compare the status of the two STO channels. In case the channels are not in the same state, a fault reaction function is performed and the drive trips on an “STO hardware failure” fault. An attempt to use the STO in a non-redundant manner, for example activating only one channel, will trigger the same reaction.

See the firmware manual of the drive control program for the indications generated by the drive, and for details on directing fault and warning indications to an output on the control unit for external diagnostics.

Any failures of the Safe torque off function must be reported to ABB.

Safety data

The safety data for the Safe torque off function is given below.

Note: The safety data is calculated for redundant use, and does not apply if both STO channels are not used.

Frame size	SIL/ SILCL	PL	SFF (%)	PFH ($T_1 = 20$ a) (1/h)	PFD _{avg} ($T_1 = 2$ a)	PFD _{avg} ($T_1 = 5$ a)	MTTF _D (a)	DC (%)	Cat.	SC	HFT	CCF	T _M (a)
$U_N = 400$ V, $U_N = 500$ V													
R6 R7	3	e	>99	2.89E-09	2.41E-05	6.02E-05	10340	≥90	3	3	1	80	20
R8 R9	3	e	99.1	3.21E-09	2.67E-05	6.67E-05	9630	≥90	3	3	1	80	20
R10 R11	3	e	99.65	3.66E-09	3.20E-05	8.01E-05	19594	≥90	3	3	1	80	20
$U_N = 690$ V													
R6 R7 R8 R9	3	e	99.1	3.21E-09	2.66E-05	6.66E-05	10008	≥90	3	3	1	80	20
R10 R11	3	e	99.65	3.66E-09	3.20E-05	8.01E-05	19594	≥90	3	3	1	80	20
3AXD10000006217 K, 3AXD10000083197 H, 3AXD10000115366 F													

- The following temperature profile is used in safety value calculations:
 - 670 on/off cycles per year with $\Delta T = 71.66$ °C
 - 1340 on/off cycles per year with $\Delta T = 61.66$ °C
 - 30 on/off cycles per year with $\Delta T = 10.0$ °C
 - 32 °C board temperature at 2.0% of time
 - 60 °C board temperature at 1.5% of time
 - 85 °C board temperature at 2.3% of time.
- The STO is a type A (frames R6...R9) or type B (frames R10 and R11) safety component as defined in IEC 61508-2.
- Relevant failure modes:
 - The STO trips spuriously (safe failure)
 - The STO does not activate when requested
 - A fault exclusion on the failure mode “short circuit on printed circuit board” has been made (EN 13849-2, table D.5). The analysis is based on an assumption that one failure occurs at one time. No accumulated failures have been analyzed.

- STO response times:
 - STO reaction time (shortest detectable break): 1 ms
 - STO response time:
 - Frames R6...R9: 2 ms (typical), 5 ms (maximum)
 - Frames R10...R11: 2 ms (typical), 30 ms (maximum)
 - Fault detection time: Channels in different states for longer than 200 ms
 - Fault reaction time: Fault detection time + 10 ms
- Indication delays:
 - STO fault indication (parameter 31.22) delay: < 500 ms
 - STO warning indication (parameter 31.22) delay: < 1000 ms

■ Abbreviations

Abbr.	Reference	Description
Cat.	EN ISO 13849-1	Classification of the safety-related parts of a control system in respect of their resistance to faults and their subsequent behavior in the fault condition, and which is achieved by the structural arrangement of the parts, fault detection and/or by their reliability. The categories are: B, 1, 2, 3 and 4.
CCF	EN ISO 13849-1	Common cause failure (%)
DC	EN ISO 13849-1	Diagnostic coverage
HFT	IEC 61508	Hardware fault tolerance
MTTF _D	EN ISO 13849-1	Mean time to dangerous failure: (Total number of life units) / (Number of dangerous, undetected failures) during a particular measurement interval under stated conditions
PFD _{avg}	IEC 61508	Average probability of dangerous failure on demand, that is, mean unavailability of a safety-related system to perform the specified safety function when a demand occurs
PFH	IEC 61508	Average frequency of dangerous failures per hour, that is, average frequency of a dangerous failure of a safety related system to perform the specified safety function over a given period of time
PL	EN ISO 13849-1	Performance level. Levels a...e correspond to SIL
SC	IEC 61508	Systematic capability
SFF	IEC 61508	Safe failure fraction (%)
SIL	IEC 61508	Safety integrity level (1...3)
SILCL	IEC/EN 62061	Maximum SIL (level 1...3) that can be claimed for a safety function or subsystem
STO	IEC/EN 61800-5-2	Safe torque off
T ₁	IEC 61508-6	Proof test interval. T ₁ is a parameter used to define the probabilistic failure rate (PFH or PFD) for the safety function or subsystem. Performing a proof test at a maximum interval of T ₁ is required to keep the SIL capability valid. The same interval must be followed to keep the PL capability (EN ISO 13849) valid. See also section Maintenance.
T _M	EN ISO 13849-1	Mission time: the period of time covering the intended use of the safety function/device. After the mission time elapses, the safety device must be replaced. Note that any T _M values given cannot be regarded as a guarantee or warranty.

■ TÜV certificate

The TÜV certificate is available on the Internet at www.abb.com/drives/documents.

■ Declaration of conformity



EU Declaration of Conformity

Machinery Directive 2006/42/EC

We

Manufacturer: ABB Oy

Address: Hiomotie 13, 00380 Helsinki, Finland.

Phone: +358 10 22 11

declare under our sole responsibility that the following products:

Frequency converters and frequency converter components

ACS880-04, -14, -34 (frames nxR8i)

ACS880-04XT, -04FXT

ACS880-07, -17, -37, -107

ACS880-104

ACS880 multidrives

ACS880-104LC (frames nxR8i)

ACS880-07CLC, -07LC, -17LC, -37LC, -107LC (frames nxR8i)

ACS880 liquid-cooled multidrives

identified with serial numbers beginning with 1 or 8

with regard to the safety functions

Safe torque off

Safe motor temperature with FPTC-01 module (option code +L536)

Safe Stop 1 (SS1-t) with FSPS-21 module (+Q986)

Safe stop 1 (SS1-t and SS1-r), Safe stop emergency, Safely-limited speed, Safe maximum speed, Safe brake control, Prevention of unexpected start-up, with FSO-12 module (option code +Q973)

Safe stop 1 (SS1-t and SS1-r), Safe stop emergency, Safely-limited speed, Safe maximum speed, Safe brake control, Safe Speed monitor, Safe direction, Prevention of unexpected start-up, with FSO-21 and FSE-31 modules (option codes +Q972 and +L521)



ACS880-07, -17, -37, -07CLC and ACS880 multidrives: Prevention of unexpected start-up (option codes +Q950; +Q957), **Emergency stop** (option codes +Q951; +Q952; +Q963; +Q964; +Q978; +Q979), **Safely-limited speed** (option codes +Q965; Q966)

are in conformity with all the relevant safety component requirements of EU Machinery Directive 2006/42/EC, when the listed safety functions are used for safety component functionality.

The following harmonized standards have been applied:

EN 61800-5-2:2007	Adjustable speed electrical power drive systems – Part 5-2: Safety requirements - Functional
EN 62061:2005 + AC:2010 + A1:2013 + A2:2015	Safety of machinery – Functional safety of safety-related electrical, electronic and programmable electronic control systems
EN ISO 13849-1:2015	Safety of machinery – Safety-related parts of control systems. Part 1: General principles for design
EN ISO 13849-2:2012	Safety of machinery – Safety-related parts of the control systems. Part 2: Validation
EN 60204-1:2018	Safety of machinery – Electrical equipment of machines – Part 1: General requirements

The following other standard has been applied:

IEC 61508:2010, parts 1-2	Functional safety of electrical / electronic / programmable electronic safety-related systems
IEC 61800-5-2:2016	Adjustable speed electrical power drive systems – Part 5-2: Safety requirements - Functional

The products referred in this Declaration of conformity fulfil the relevant provisions of other European Union Directives which are notified in Single EU Declaration of conformity 3AXD10000497305.

Person authorized to compile the technical file:

Name and address: Vesa Tiihonen, Hiomotie 13, 00380 Helsinki, Finland

Helsinki, 18 Sep 2020

Signed for and on behalf of:

Peter Lindgren
Vice President, ABB Oy

Vesa Tiihonen
Manager, Product Engineering and Quality

15

Resistor braking

Contents of this chapter

This chapter tells how to select, protect and wire brake choppers and resistors. The chapter also contains the related technical data.

When is resistor braking necessary?

Resistor braking is necessary for high capacity braking if a regenerative drive cannot be used.

Operation principle and hardware description

The drive can be equipped with an optional built-in brake chopper (+D150). Brake resistors are available as add-on kits or factory installed (+D151).

The brake chopper handles the energy generated by a decelerating motor. During the deceleration, motor generates energy back to the drive and the voltage in the drive intermediate DC link starts to rise. The chopper connects the brake resistor to the intermediate DC circuit whenever the voltage in the circuit exceeds the limit defined by the control program. Energy consumption by the resistor losses lowers the voltage until the resistor can be disconnected.

Planning the braking system

■ Selecting the brake circuit components

Selecting the default brake system components

1. Calculate the maximum power generated by the motor during braking.
2. Select a suitable drive, brake chopper and brake resistor combination for the application from the brake ratings table below. The braking power of the chopper must be greater than or equal to the maximum power generated by the motor during the braking.
3. Make sure that the resistor selection is correct: The energy generated by the motor during a 400-second period must not exceed the resistor heat dissipation capacity E_R .

Note: If the E_R value is not sufficient, it is possible to use a four-resistor assembly in which two standard resistors are connected in parallel, two in series. The E_R value of the four-resistor assembly is four times the value specified for the standard resistor.

Selecting a custom brake resistor

If you use other than ABB resistor,

1. make sure that the resistance of the custom resistor is greater than or equal to the resistance of the default ABB resistor.

$$R \geq R_{\min}$$

where

R Resistance of the custom resistor



WARNING!

Never use a brake resistor with a resistance smaller than R_{\min} . The drive and the chopper are not able to handle the overcurrent caused by the small resistance.

R_{\min} Resistance of the default resistor



WARNING!

Never use a brake resistor with a resistance smaller than R_{\min} . This will cause overcurrent that will damage the brake chopper and the drive.

2. make sure that the resistance of the custom resistor does not restrict the braking capability needed, ie.

$$P_{\max} < \frac{U_{DC}^2}{R}$$

where

P_{\max} Maximum power generated by the motor during braking

U_{DC} Drive intermediate DC circuit voltage.
 1.35 · 1.2 · 415 V DC (when supply voltage is 380 to 415 V AC)
 1.35 · 1.2 · 500 V DC (when supply voltage is 440 to 500 V AC) or
 1.35 · 1.2 · 690 V DC (when supply voltage is 525 to 690 AC)

R Resistance of the custom resistor

3. make sure that the resistor can dissipate the energy transferred to it during the braking:
 - Braking energy is not greater than the resistor heat dissipation capacity (E_r) during the period specified. See the custom resistor specification.
 - The resistor is installed in a correctly ventilated and cooled space. Otherwise the resistor cannot meet its heat dissipation capacity and overheats.
4. make sure that the instantaneous load capacity of the custom resistor is greater than the maximum power taken by the resistor when it is connected to the drive intermediate DC circuit by the chopper:

$$P_{R,inst} > \frac{U_{DC}^2}{R}$$

where

$P_{R,inst}$	Instantaneous load capacity of the custom resistor
U_{DC}	Drive intermediate DC circuit voltage. 1.35 · 1.2 · 415 V DC (when supply voltage is 380 to 415 V AC) 1.35 · 1.2 · 500 V DC (when supply voltage is 440 to 500 V AC) or 1.35 · 1.2 · 690 V DC (when supply voltage is 525 to 690 AC)
R	Resistance of the custom resistor

Selecting and routing the cables of custom resistors

Cable type

Use the same cable type for the resistor cabling as for the drive input cabling or, alternatively, a two conductor shielded cable with the same cross-sectional area.

Maximum cable length

The maximum length of the resistor cable(s) is 10 m (33 ft).

Minimizing electromagnetic interference

Obey these rules in order to minimize electromagnetic interference caused by the rapid current changes in the resistor cables:

- Shield the braking power line completely, either by using shielded cable or a metallic enclosure. Unshielded single-core cable can only be used if it is routed inside a cabinet that efficiently suppresses the radiated emissions.
- Install the cables away from other cable routes.
- Avoid long parallel runs with other cables. The minimum parallel cabling separation distance is 0.3 meters (1 ft).
- Cross the other cables at 90 degree angles.
- Keep the cable as short as possible in order to minimize the radiated emissions and stress on chopper IGBTs. The longer the cable the greater the radiated emissions, inductive load and voltage peaks over the IGBT semiconductors of the brake chopper.

Note: ABB has not verified that the EMC requirements are fulfilled with custom brake resistors and cabling. The customer must consider the EMC compliance of the complete installation.

■ Placing the brake resistor

Install the resistor assembly outside the drive in a place where it is able to cool effectively.

Arrange the cooling of the resistor in a way that:

- no danger of overheating is caused to the resistor or nearby materials, and
- the temperature of the room the resistor is located in does not exceed the allowed maximum.

Supply the resistor with cooling air or coolant according to the resistor manufacturer's instructions.



WARNING!

The materials near the brake resistor must be non-flammable. The surface temperature of the resistor is high. Air flowing from the resistor is of hundreds of degrees Celsius. If the exhaust vents are connected to a ventilation system, make sure that the material withstands high temperatures. Protect the resistor against contact.

■ Protecting the system against thermal overload

The brake chopper protects itself and the resistor cables against thermal overload when the cables are dimensioned according to the nominal current of the drive. The drive control program includes a resistor overload protection function which can be tuned by the user. See the firmware manual.

A main contactor is not required for protecting against resistor overheating when the resistor is dimensioned according to the instructions and the internal brake chopper is in use. The drive will disable power flow through the input bridge if the chopper remains conductive in a fault situation but the charging resistor may fail.

Note: If an external brake chopper (outside the drive module) is used, a main contactor is always required.

A thermal switch is required for safety reasons. The standard resistors available as option +D151 are equipped with a thermal switch. The switches of the resistors are wired in series and connected in the Run enable loop of the drive. With custom resistors, a similar protection must be implemented.

Use a thermal switch cable rated as follows:

- twisted pair, shielding recommended
- rated operating voltage between a conductor and ground (U_0) \geq 750 V
- insulation test voltage $>$ 2.5 kV.

Wire the switch to a digital input on the drive control unit. Consider connecting the thermal switch in the Run enable loop connected to the DIIL input. See the circuit diagrams of the drive.

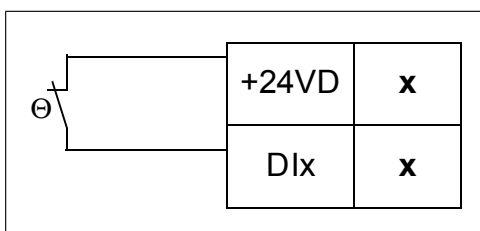

■ Protecting the brake resistor cable against short-circuits

The input fuses for the drive also protect the resistor cable against short-circuits when the resistor cable is identical with the input cable .

Mechanical installation of custom brake resistors

All brake resistors must be installed outside the drive. Obey the resistor manufacturer's instructions.

Electrical installation of custom brake resistors

■ Measuring the insulation of the custom brake resistor circuit



WARNING!

Obey the safety instructions of the drive. If you ignore them, injury or death, or damage to the equipment can occur. If you are not a qualified electrical professional, do not do installation or maintenance work.

1. Stop the drive and do the steps in section [Electrical safety precautions \(page 18\)](#) before you start the work.
2. Make sure that the resistor cable is connected to the resistor and disconnected from the drive output terminals.
3. At the drive end, connect the R+ and R- conductors of the resistor cable together. Measure the insulation resistance between the conductors and the PE conductor with a measuring voltage of 1000 V DC. The insulation resistance must be more than 1 Mohm.

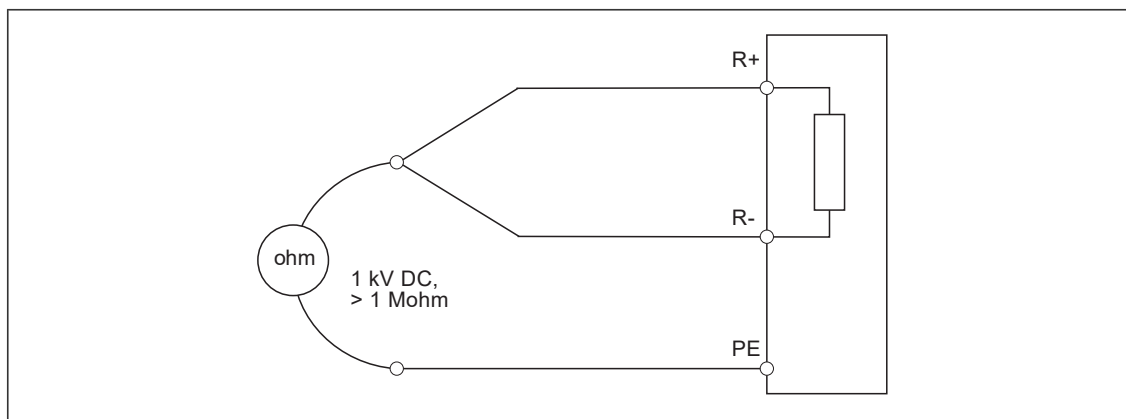

Start-up

Note: New brake resistors may be coated with storage grease. As the brake chopper operates for the first time, the grease burns off and may produce some smoke. Make sure there is sufficient ventilation.

■ Parameter settings

Set the following parameters:

- Disable the overvoltage control of the drive with parameter *30.30 Overvoltage control*.

With custom resistors (no option +D151):

- If the thermal switch is wired to the DIIL input, an overheating resistor will, by default, remove the Run enable signal from the drive. See also parameters 20.11 Run enable stop mode, 20.12 Run enable 1 source and 95.20 HW options word 1.
- If the thermal switch is wired to another digital input input, set the following parameters.

Set the source of parameter 31.01 External event 1 source to point to the digital input where the thermal switch of the brake resistor is wired.

Enable the brake chopper by parameter 43.06 Brake chopper enable. If Enabled with thermal model is selected, set also the brake resistor overload protection parameters 43.08 and 43.09 according to the application.

Set parameter 31.02 External event 1 type to Fault.

Set parameter 43.07 Brake chopper run enable to Other [bit] and select from parameter 10.01 DI status the digital input where the thermal switch of the brake resistor is wired.

Set the resistance value of the resistor to parameter 43.10 Brake resistance.

With these parameter settings, the drive generates a fault and coasts to a stop on brake resistor overtemperature.



WARNING!

If the drive is equipped with a brake chopper but the chopper is not enabled by the parameter setting, the internal thermal protection of the drive against resistor overheating is not in use. In this case, the brake resistor must be disconnected.

Technical data

■ Ratings

ACS880-07-...	Internal brake chopper		Example brake resistor(s)			
	P_{brcont}	R_{min}	Type	R	E_R	P_{Rcont}
	kW	ohm		ohm	kJ	kW
$U_n = 400\text{ V}$						
0105A-3	55	5.4	SAFUR80F500	6.0	2400	6
0145A-3	75	5.4	SAFUR80F500	6.0	2400	6
0169A-3	90	3.3	SAFUR125F500	4.0	3600	9
0206A-3	110	3.3	SAFUR125F500	4.0	3600	9
0246A-3	132	2.3	SAFUR200F500	2.7	5400	13.5
0293A-3	132	2.3	SAFUR200F500	2.7	5400	13.5
0363A-3	160	2.0	SAFUR200F500	2.7	5400	13.5
0430A-3	160	2.0	SAFUR200F500	2.7	5400	13.5
0505A-3	250	2.0	2×SAFUR125F500	2.00	7200	18
0585A-3	315	1.3	2×SAFUR200F500	1.35	10800	27
0650A-3	315	1.3	2×SAFUR200F500	1.35	10800	27
0725A-3	400	0.7	3×SAFUR200F500	0.90	16200	40
0820A-3	400	0.7	3×SAFUR200F500	0.90	16200	40
0880A-3	400	0.7	3×SAFUR200F500	0.90	16200	40
$U_n = 500\text{ V}$						

ACS880-07-...	Internal brake chopper		Example brake resistor(s)			
	P_{brcont}	R_{min}	Type	R	E_R	P_{Rcont}
	kW	ohm		ohm	kJ	kW
0096A-5	55	5.4	SAFUR80F500	6.0	2400	6
0124A-5	75	5.4	SAFUR80F500	6.0	2400	6
0156A-5	90	3.3	SAFUR125F500	4.0	3600	9
0180A-5	110	3.3	SAFUR125F500	4.0	3600	9
0240A-5	132	2.3	SAFUR200F500	2.7	5400	13.5
0260A-5	132	2.3	SAFUR200F500	2.7	5400	13.5
0302A-5	160	2.3	SAFUR200F500	2.7	5400	13.5
0361A-5	160	2.3	SAFUR200F500	2.7	5400	13.5
0414A-5	160	2.3	SAFUR200F500	2.7	5400	13.5
0460A-5	250	2.0	2×SAFUR125F500	2.00	7200	18
0503A-5	250	2.0	2×SAFUR125F500	2.00	7200	18
0583A-5	315	1.3	2×SAFUR200F500	1.35	10800	27
0635A-5	315	1.3	2×SAFUR200F500	1.35	10800	27
0715A-5	400	0.7	3×SAFUR200F500	0.90	16200	40
0820A-5	400	0.7	3×SAFUR200F500	0.90	16200	40
$U_n = 690$ V						
0061A-7	55	13	SACE15RE13	13.0	435	2
0084A-7	65	13	SACE15RE13	13.0	435	2
0098A-7	90	8	SAFUR90F575	8.0	1800	4.5
0119A-7	110	8	SAFUR90F575	8.0	1800	4.5
0142A-7	132	6	SAFUR80F500	6.0	2400	6
0174A-7	160	6	SAFUR80F500	6.0	2400	6
0210A-7	200	4	SAFUR125F500	4.0	3600	9
0271A-7	200	4	SAFUR125F500	4.0	3600	9
0330A-7	285	2.2	SAFUR200F500	2.7	3600	13
0370A-7	285	2.2	SAFUR200F500	2.7	3600	13
0430A-7	285	2	SAFUR200F500	3	3600	13
0425A-7	350	2	2×SAFUR125F500	2	7200	18
0470A-7	350	2	2×SAFUR125F500	2	7200	18
0522A-7	350	2	2×SAFUR125F500	2	7200	18
0590A-7	400	2	2×SAFUR125F500	2	7200	18
0650A-7	400	1.8	2×SAFUR125F500	2	7200	18
0721A-7	400	1.8	2×SAFUR125F500	2	7200	18
3AXD10000044776						

P_{brcont} Maximum continuous braking power. The braking is considered continuous if the braking time exceeds 30 seconds.

R_{min} The minimum allowed resistance value of the brake resistor

R Resistance value for the listed resistor assembly

E_R Short energy pulse that the resistor assembly withstands every 400 seconds

268 Resistor braking

P_{Rcont} Continuous power (heat) dissipation of the resistor when placed correctly

The ratings apply at an ambient temperature of 40 °C (104 °F).

■ Degree of protection of SAFUR resistors

The degree of protection of SAFUR resistors is IP00.

■ Terminals and cable entry data

See section [Terminal and entry data for the power cables \(page 216\)](#).

Further information

Product and service inquiries

Address any inquiries about the product to your local ABB representative, quoting the type designation and serial number of the unit in question. A listing of ABB sales, support and service contacts can be found by navigating to www.abb.com/searchchannels.

Product training

For information on ABB product training, navigate to new.abb.com/service/training.

Providing feedback on ABB manuals

Your comments on our manuals are welcome. Navigate to new.abb.com/drives/manuals-feedback-form.

Document library on the Internet

You can find manuals and other product documents in PDF format on the Internet at www.abb.com/drives/documents.



www.abb.com/drives



3AUA0000105718G