

Signalling Hooter HGK

High-volume signalling device for dry and damp rooms and outdoor applications



Overview

The HGK Signalling Hooter is used for indicating, calling and warning purposes. The robust, sealed housing of ingress protection IP 65 allows for a wide range of application areas, both in dry and damp rooms as well as outdoors.

The device is driven by a powerful, non-polarized electromagnet with an adjustable tappet. Powered by alternating current, the tappet hits the membrane 100 to 120 times per second.

The DC version additionally comprises an electronic circuit breaker.

The housing consists of a bottom made of die-cast aluminium and an impact-resistant thermoplastic housing cover.

The hooter is equipped with one M20 x 1.5 cable gland and one M20 x 1.5 blind plug.

The sound of the signal is dominated by deep frequencies with the volume peaking at approx. 850 Hz. This makes it especially easy to discern the signal among higher-frequency ambient noise.

The signalling hooter is available in various versions for all usual supply voltages.

Features

- Die-cast aluminium housing with an impactresistant thermoplastic cover
- Volume approx. 108 dB(A)
- Ingress protection degree IP 65
- Continuous operation
- Various connection voltages

EATON

Powering Business Worldwide

Specifications

Housing	Die-cast aluminium with cover made of impact-resistant thermoplastic
Colour	Housing dark grey, housing cover light grey
Ingress protection	IP 65 according to IEC 60529
Protection class	I
Cable glands	1x M20 x 1.5 cable gland cable diameters 8-12 mm 1x M20 x 1.5 blind plug
Connection terminals	For line diameters up to 1.5 mm ²
Volume	Approx. 108 dB(A), in 1 m distance
Operating conditions	Indoors and outdoors
Operating position	Housing vertical with cable gland facing downward
Operating mode	Continuous operation
Temperature range	-20 °C to +60 °C
Weight	1.75 kg

General arrangement drawing (all dimensions in mm)

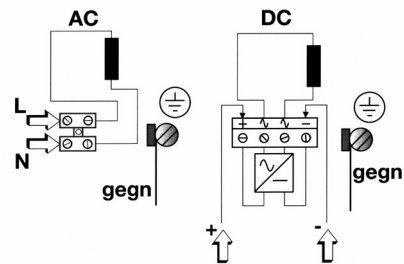
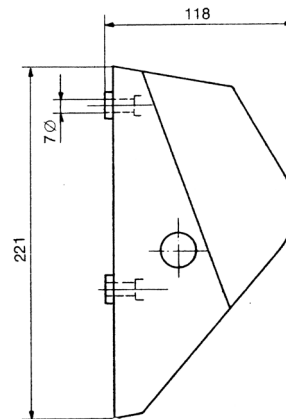
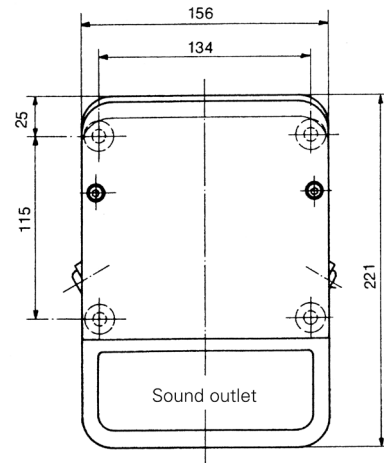

Ordering data

Type	Designation	Input voltage	Tolerance	Current consumption	Art. No.
HGK	Signalling Hooter	230 VAC, 50 Hz	+10/-15 %	0.1 A	FHF 212 600 07
HGK	Signalling Hooter	24 VDC	+10/-15 %	0.3 A	FHF 212 600 13
HGK	Signalling Hooter	120 VAC	+10/-15 %	0.15 A	FHF 212 601 06