

DC DRIVES

ABB industrial drives

Supplement for functional safety converters

DCS880 Size H1 ... H8

Original Instruction

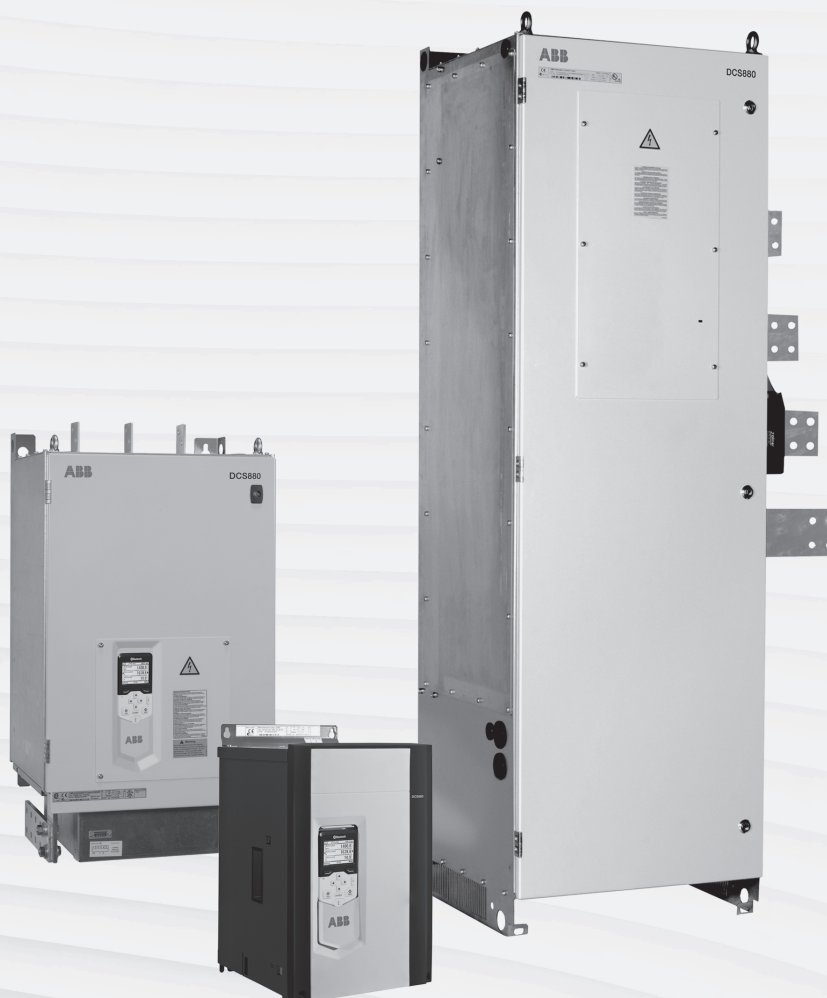

STO terminal layout

XSMC		Main contactor			
1	MCCOM		250 V _{AC} / 30 V _{DC} , 2 A	AC contactor control	XSMC:MC
2	MCNO		Maximum wire size 2.5 mm ² Varistor protected		
3	STOCOM		250 V _{AC} / 30 V _{DC} , 2 A	Fault shut down path	XSMC:STO
4	STONO		Maximum wire size 2.5 mm ² Varistor protected		
XSTO		Safe torque off			
1	OUT1	+24 V _{DC} , maximum wire size 2.5 mm ² , consumption max. 150 mA			
2	SGND	Common ground (connected to frame), maximum wire size 2.5 mm ²			
3	IN1	STO input is high $\geq 16 V_{DC}$, STO input is low $\leq 7.5 V_{DC}$, open circuit blocks firing pulses			
4	IN2				

Table 1 "STO terminal layout"

SA_880_009_DCS_c.ai

General

In DCS880 series of converters, opening the hardware circuit between terminals [XSTO:IN1]-[XSTO:OUT1] or between terminals [XSTO:IN2]-[XSTO:OUT1] stops the firing pulses to the thyristors, coasting the motor to a stop. This is the Safe Torque Off (STO) function described in IEC/EN61800-5-2 compliant with Functional Safety Standard. Using the DCS880's Safe Torque Off (STO) of DCS880 function eliminates the need of external safety circuit contactors, AC-breakers or DC-breakers while conventional converters need those breakers to configure the Functional Safety Standard compliant safety system.

Still a (non-safety) breaker needs to be connected to XSMC:3/4 for the fault shutdown path (see schematic below). This relay is closed at all times except if a STO hardware fault inside the drive occurs.



Warning

The shutdown function of DCS880 uses the Safe Torque Off (STO) function prescribed in IEC/EN61800-5-2. It does not completely shut off the power supply to the motor. Depending upon applications, additional measures are necessary for the safety of end-users. E.g., a brake function that locks the machinery and a motor terminal protection that prevents possible electrical hazard(s). The output shutdown function does not completely shut off the power supply to the motor. Before starting wiring or maintenance jobs on the converter, be sure to disconnect the input power to the converter and wait at least five minutes.



Otherwise, an electric shock could occur.

Basic schematics for an Emergency STOP cat. 0 circuit

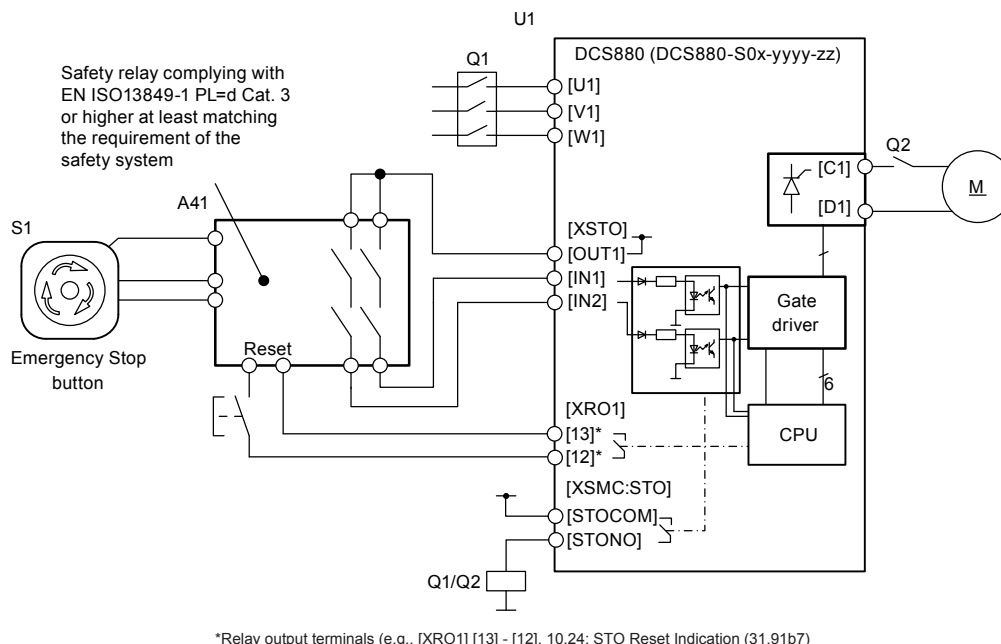

*Relay output terminals (e.g., [XRO1] [13] - [12], 10.24: STO Reset Indication (31.91b7)

Figure 1 "Basic schematics for an Emergency STOP cat. 0 circuit"

SF_880_018_Emergency STOP_e.ai

Attention:

According to IEC/EN 60 204-1 part 9.2.5.4.2 it is not allowed to restart automatically after an emergency stop. Therefore the machine control has to disable the automatic start after an emergency stop.

Notes for compliance to Functional Safety Standard

1) Wiring for terminals [XSTO:IN1] (STO Input 1) and [XSTO:IN2] (STO input 2)

[IN1] or [IN2] and [OUT1] are terminals prepared for connection of safety related wires. Therefore, careful wiring should be performed to ensure that no short-circuit(s) can occur to these terminals. Stopping the current flowing through terminal [IN1] or [IN2] activates the STO function. For opening and closing the hardware circuit between terminals [IN1] or [IN2] and [OUT1], use safety approved components such as safety relays that comply with EN ISO13849-1 PL=e Cat. 3 or higher to ensure a complete shutoff.

It is the responsibility of the machinery manufacturer to guarantee that a short-circuiting or other fault does not occur in wiring of external safety components between terminals [IN1] or [IN2] and [OUT1].

Fault examples:

- Terminals [IN1] or [IN2] and [OUT1] are short-circuited due to the wiring being caught in the door of the cabinet so that a current continues to flow in terminal [IN1] or [IN2] although the safety component is OFF and therefore the safety function may NOT operate.
- The wiring is in contact with any other wire so that a current continues to flow in terminal [IN1] or [IN2] and therefore the safety function may NOT operate.

To activate the STO function correctly, be sure to keep terminals [IN1] and [IN2] OFF for at least 50 ms. When inputting test pulses sent from the safety PLC to terminals [IN1] and [IN2], keep the pulse width of the OFF signal to 1 ms or less.

2) Note for Safe Torque Off (STO)

When configuring the product safety system with this Safe Torque Off (STO) function, make a risk assessment of not only the external equipment and wiring connected to terminals [IN1] and [IN2] (STO input 1 and STO input 2) but also of the whole system. This includes other equipment, devices and wiring against the product safety system required by the machinery manufacturer under the manufacturer's responsibility in order to confirm that the whole system conforms to the product safety system required by the machinery manufacturer.

In addition the machinery manufacturer must perform periodical inspections and preventive maintenance to check that the product safety system functions properly. To bring the converter into compliance with the Functional Safety Standard, it is necessary to install the converter in a Pollution Degree 2 environment or in a cabinet with the enclosure rating of IP54 or above.

To bring the converter into compliance with Functional Safety Standard, it is necessary to bring it into compliance with European Standards IEC/EN61800-5-1 and IEC/EN61800-3.

This Safe Torque Off (STO) function coasts the motor to a stop. When a mechanical brake is used to stop or hold the motor for the sake of the safety of the whole system, do not use the converter's control signals such as the output from terminal [XRO]. (Using control signals does not satisfy the safety standards because of software intervention.) Use safety relay units complying with EN ISO13849-1 PL=e Cat. 3 or higher to activate mechanical brakes.

The safety shutdown circuit between terminal [IN1] and [IN2] input sections and the converter's output shutdown section is dual-configured (redundant circuit) so that an occurrence of a single fault does not detract the Safe Torque Off (STO). If a single fault is detected in the safety shutdown circuit, the converter coasts the motor to a stop even with the [IN1]-[OUT1] and [IN2]-[OUT1] states being ON, as well as outputting an alarm to external equipment. (Note that the alarm output function is not guaranteed to all of single faults. It is compliant with EN ISO13849-1 PL=e Cat. 3).

The Safe Torque Off (STO) function does not completely shut off the power supply to the motor. Before starting wiring or maintenance jobs, be sure to disconnect the input power to the converter. For details, refer to "wiring" in the safety precautions given.

3) Check the wiring

If the wiring is changed in the initial start-up or maintenance. To be sure perform the following test with the converter stopped.

Turn each of terminals [IN1] and [IN2] OFF (open) and ON (short) and check the 31.91 STO statusword using the assistant control panel. Check that the relevant signal turns "signal ON" and "signal OFF," respectively.

4) Exceptionally high line overvoltage

Exceptionally high line overvoltage, more than 5 times rated line voltage for example direct lightning strike, could possibly lead to a short jerk of the shaft.

Converter output state when Safe Torque OFF (STO) is activated

Turning the emergency stop button to ON sets [IN1] and [IN2] to OFF and forces the converter into the state Safe Torque OFF (STO).

Figure 2 “Converter state when the Emergency Stop Button is not pressed while the converter stopped” shows the timing scheme to apply when the emergency stop button is not pressed while the converter stopped. State at inputs [IN1] and [IN2] become HIGH and the converter is ready to operate.

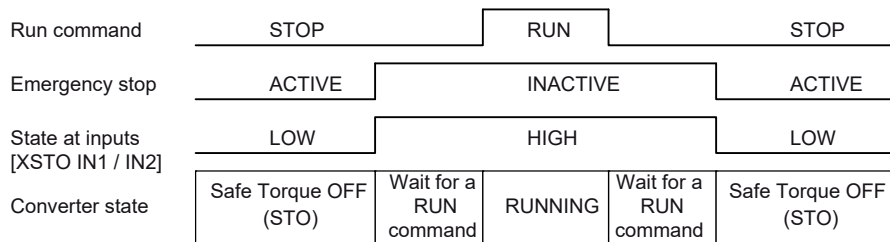

Figure 2 “Converter state when the Emergency Stop Button is not pressed while the converter stopped” DZ_LIN_030_STO_c.ai

Figure 3 “Converter state when the Emergency Stop Button is pressed while the converter running” shows the timing scheme to apply when the emergency stop button is pressed while the converter running. Inputs to [IN1] and [IN2] become LOW, bringing the converter into state Safe Torque OFF (STO) and coast the motor to stop.

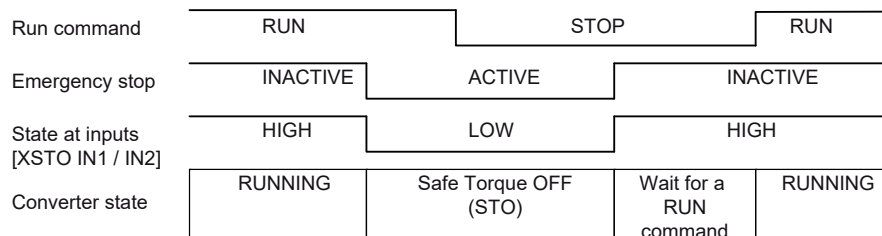

Figure 3 “Converter state when the Emergency Stop Button is pressed while the converter running” DZ_LIN_030_STO_c.ai

Functional safety performance

Table 2a lists the safety performance values for DCS880 drives

Stop Function	Safe Torque OFF (STO)	(IEC/EN61800-5-2:2017)
Response time	500 ms or less (From input to the terminal until Safe Torque OFF)	
Safety integrity level	SIL2	(IEC/EN62061:2015)
Performance level	PL-d	(EN/ISO13849-1:2015)
Diagnostic test interval	once per year	once per 3 month (IEC61800-5-2:2016)
Acceptance test ①	common ABB wording (IEC/EN61800-5-2:2017)	
PFH (Probability of a dangerous random hardware failure per hour)		
Unit size:		
H1 ... H6	5,16 E-10 1/h	
H7 ... H8	1,44 E-09 1/h	
2 x hard parallel	2,79 E-09 1/h	
3 x hard parallel	4,29 E-09 1/h	
4 x hard parallel	5,94 E-09 1/h	
DC average	90 %	(EN/ISO13849-1:2015)
MTTFd (Mean time to dangerous random hardware failure)	100 a	(EN/ISO13849-1:2015)
Category	3	(EN/ISO13849-1:2015)
Hardware fault tolerance	HFT1	(IEC/EN61800-5-2:2017)
Systematic capability	SC3	(IEC/EN61800:2010)
Proof test interval	20 years	

Table 2b lists the safety performance for a safety system consisting of DCS880 + FSPS-21 + PROFIsafe

Stop Function	Safe Torque OFF (STO), Safe Stop 1 (SS1-t)				(IEC/EN61800-5-2:2017)
Response time ②	510 ms or less (from the moment the FSPS-21 module has received the STO function request until the drive has achieved STO)				
Safety integrity level	SIL2	SIL3	SIL2	SIL3	(IEC/EN62061:2015)
Performance level	PL-d	PL-e	PL-d	PL-e	(EN/ISO13849-1:2015)
Diagnostic test interval	once per year	once per 3 month	once per year	once per 3 month	(IEC61800-5-2:2016)
Acceptance test ①	common ABB wording				
Site elevation	At sea level ③		At 4000 m above sea level ③		
PFH (Probability of a dangerous random hardware failure per hour)					
Unit size:					
H1 ... H8	1,32 E-08 1/h		5,41 E-08 1/h		
2 x hard parallel	1,46 E-08 1/h		5,55 E-08 1/h		
3 x hard parallel	1,61 E-08 1/h		5,70 E-08 1/h		
4 x hard parallel	1,77 E-08 1/h		5,86 E-08 1/h		
DC average	94,95 %		98,58 %		(EN/ISO13849-1:2015)
MTTFd (Mean time to dangerous random hardware failure)	45,63 a		9,61 a		(EN/ISO13849-1:2015)
Category	3				(EN/ISO13849-1:2015)
Hardware fault tolerance	HFT1				(IEC/EN61800-5-2:2017)
Systematic capability	SC3				(IEC/EN61800:2010)
Proof test interval	20 years				

① It is strongly recommended to also perform the repetitive function test in the same test interval.

② Attention: This does not include the response times and watchdog times of the PROFIsafe communication.

To calculate the total response time the technical data of the safety PLC and the input device is needed.

It is the responsibility of the machinery manufacturer to do this calculation according to the FSPS-21 manual (3ADW000624).

③ Use linear interpolation to calculate the values for intermediate altitudes.

Table 2 "Functional safety performance"

Safe Torque OFF (STO) Indications

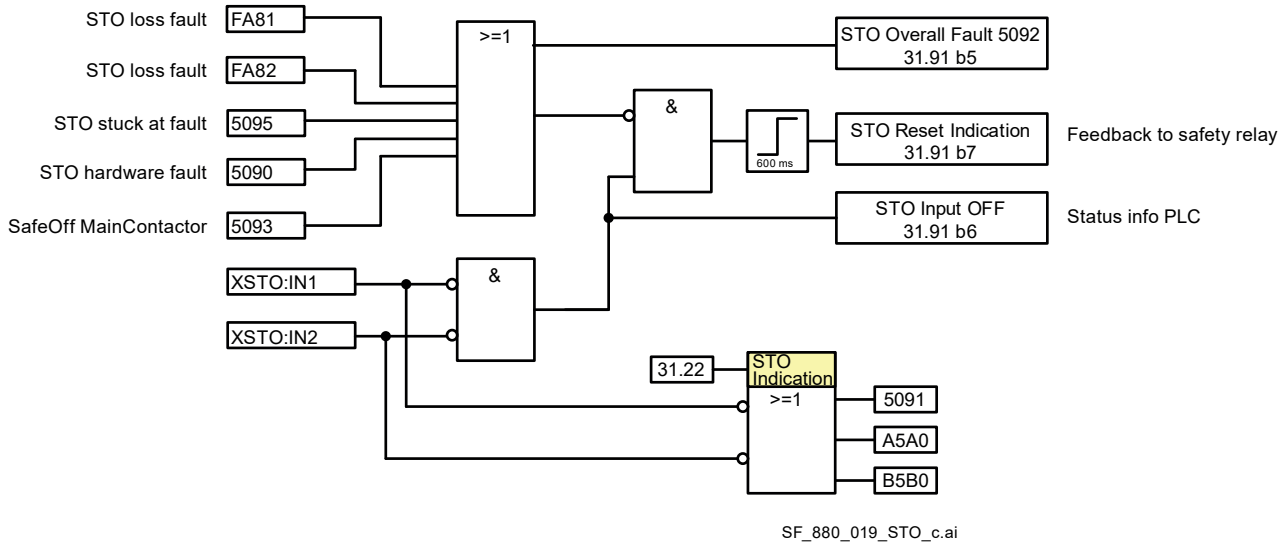

Figure 4 “Safe Torque OFF (STO) Indications”

Safe Torque OFF (STO) loss faults

This fault signal becomes ON when a logic and timing discrepancy between STO inputs [IN1] and [IN2] is detected.
 Fault codes: FA81, FA82

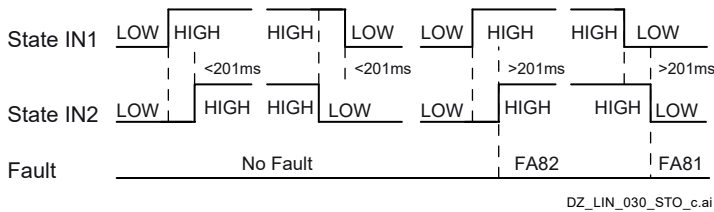

Figure 5 “Safe Torque OFF (STO) loss faults”

Possible Causes (FA81 & FA82)	What to check and suggested measures
a) Poor contact of the control circuit terminals	Check that the control circuit terminals are secured to the converter
b) STO input logic error	Check the ON/OFF timing of XSTO [IN1] and [IN2] → Check that jumpers between [OUT1] and [IN1] and [OUT1] and [IN2] are removed → Operate the safety relay so that the ON/OFF timing of [IN1] and [IN2] are synchronized → Check whether the safety relay contacts are not welded. If welded replace the relay → Check the gap between ON/OFF timing of [IN1] and [IN2]. Keep the gap within 201 ms
c) STO circuit fault	Take the measures given in b) above → If the error persists, ask your ABB representative to repair the converter

Table 3 “Possible causes”

XSMCSTO Indication (Motor current supervision)

SafeOFF MainContactor Fault code: 5093 ; Warning code: A5A3; Event code: B5A3

DCS880 offers the possibility to open the main contactor by hardware supervision of the motor current in case of STO request.

In case STO is requested and current zero is detected in < 300 ms the XSMC:STO relay is kept closed.

In case the current zero is not detected in < 300 ms the XSMC:STO relay is opened.

SafeOFF MainContactor indication is given as configured by parameter 31.90, in case current zero is not detected in < 300 ms after the request.

Reset is only possible by control board boot: 96.08 = 1

31.90 XSMCSTO Indication (Zero current time out indication)
0 Fault 5093; SafeOFF MainContactor
1 Warning A5A3
2 Event B5A3

Table 4 “XSMCSTO Indication”

Status of XSMC:STO can be supervised by 31.91b4.

Safe Torque OFF (STO) Hardware Fault

Fault code: 5090

This signal becomes ON when the CPU detects any hardware fault of the STO circuit.

The converter output is shut down (STO).

Measures: Contact your ABB representative and ask to repair the drive.

Safe Torque OFF (STO) Overall Fault

Fault code: 5092

This signal becomes ON when any of the following faults is detected in the Safe Torque OFF (STO) related circuits.

Trigger faults: FA81 or FA82 or 5090 or 5093 or 5095.

Those signals do not assure detection of all single faults (compliant with EN ISO 13849-1 PL e Cat.3)

Safe Torque OFF (STO) Reset indication

This signal becomes ON when no STO related fault is active and the STO Input OFF signal is ON, 31.91b7.

Safe Torque OFF (STO) Input OFF

This signal, 31.91b6, becomes ON when STO Inputs [IN1] and [IN2] are OFF (opened).

Logic Table for STO OFF and Safe Torque OFF Loss

Auxillary power Input	STO Input [XSTO]		Firmware Functions STO Status		Output
	XSTO:3	XSTO:4	STO Input OFF	Safe Torque OFF Loss Fault	
OFF	X	X	OFF	–	Shut down (Safe Torque OFF (STO))
ON	OFF	OFF	ON	–	Shut down (Safe Torque OFF (STO))
	OFF	ON	OFF	FA81	Shut down (Safe Torque OFF (STO))
	ON	OFF	OFF	FA81	Shut down (Safe Torque OFF (STO))
	ON	ON	OFF	–	Normal Operation

Table 5 "Safe Torque OFF (STO) Input OFF"

Safe Torque OFF (STO) Indication

The Safe Torque OFF (STO) Indication selects which indications are given when one or both Safe Torque OFF (STO) signals are switched off or lost. The indications also depend on whether the drive is running or stopped when a Safe Torque OFF (STO) occurs.

The table 6 shows the indications generated depending on the indication setting.

Notes:

This parameter does not affect the operation of the Safe Torque OFF (STO) function itself. The Safe Torque OFF (STO) function will operate regardless of the setting of this parameter: a running drive will stop (coast) upon removal of one or both Safe Torque OFF (STO) signals, and will not start until both Safe Torque OFF (STO) signals are restored and all faults reset.

The loss of only one Safe Torque OFF (STO) signal always generates a fault as it is interpreted as a malfunction.

Fault code: 5091; Warning code: A5A0; Event code: B5A0

Setting of 31.22 STO indication run/stop		Fault / Fault	Fault / Warning		Fault / Event		Warning / Warning		Event / Event		No indication / No indication		Warning / Event		
IN1	IN2		running	stopped	running	stopped	running	stopped	running	stopped	running	stopped	running	stopped	
0	0	5091	5091	A5A0	5091	B5A0	A5A0	A5A0	B5A0	B5A0	None	None	A5A0	B5A0	
0	1	5091	5091	A5A0	5091	B5A0	A5A0	A5A0	B5A0	B5A0	None	None	A5A0	B5A0	
1	0	5091	5091	A5A0	5091	B5A0	A5A0	A5A0	B5A0	B5A0	None	None	A5A0	B5A0	
1	1	normal operation													

Table 6 "Safe Torque OFF (STO) Indication"

31.91 STO Status Word

Bitlist:

31.91 STO Status Word	
0	STO State (high converter output enabled)
1	reserved
2	XSTO IN1 (high closed)
3	XSTO IN2 (high closed)
4	XSMC STO (high closed)
5	STO Overall Fault (high fault active)
6	STO Input OFF (high both inputs OFF)
7	STO Reset Indication (high reset permissible)
8	Current zero (high current zero detected)
9 ... 15	reserved

Table 7 "STO Status word"

31.94 STO time 1

Time after XSTO:IN1 1 → 0 till firing pulses been blocked for first STO channel

31.95 STO time 2

Time after XSTO:IN2 1 → 0 till firing pulses been blocked for second STO channel

31.100 STO Test Mode

Bitlist:

31.100 STO Test Mode	
0	None; normal STO behaviour
1	No Block; firmware does not act on STO request, after STO execution by hardware and 31.98b10 = 0, Parameter returns to 0: None position
2	Trigger XSMC:STO; manually triggers the XSMC:STO relay

Table 8 "STO Test mode"

STO detailed timing chart

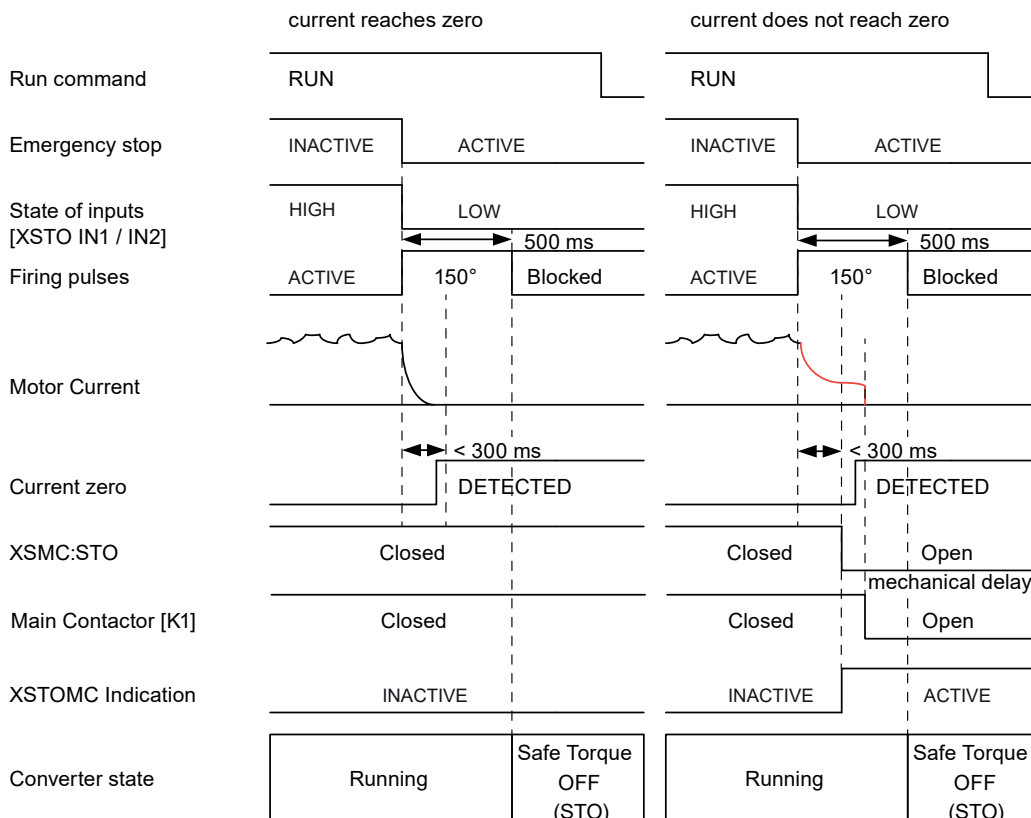



DZ_LIN_030_STO_c.ai

Figure 6 "STO detailed timing chart"

Only for frame sizes H7 and H8

Frame sizes H7 and H8 have separated control unit and power unit, so an additional connection for STO must be made. Internal STO connection. The hardware is double plastic fibre optic POF.

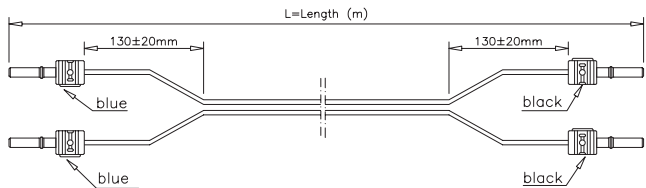
Control unit connection SDCS-DSL-H12	Power unit connection SDCS-OPL-H01	Connection	
		Permissible cable	3ADT693752P0004
		Max cable length	5 m
			

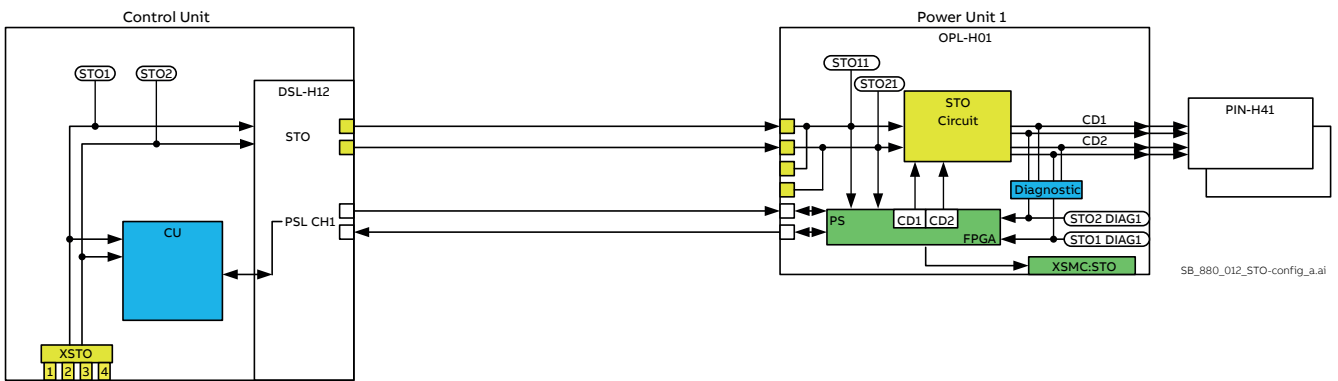

Figure 7 "Schematic STO configuration for H7 and H8"

Safe Torque OFF (STO) stuck at fault

Fault code: 5095

If a discrepancy between STO signals in the control unit and power unit is detected the converter output is shut down.

Aux code	
0	Power unit CH1 STO1 stuck at low
1	Power unit CH1 STO1 stuck at high
2	Power unit CH1 STO2 stuck at low
3	Power unit CH1 STO2 stuck at high

Table 9 "Safe Torque OFF (STO) stuck at fault"

Possible causes	Actions
Check for loose cable connection	Replug loose cable
Broken SDCS-DSL-H12	Exchange SDCS-DSL-H12 (contact ABB to perform revalidation test)
Broken SDCS-OPL-H01	Exchange SDCS-OPL-H01 (contact ABB to perform revalidation test)

Table 10 "Safe Torque OFF (STO) stuck at fault"

Flow chart, all frame sizes

Acceptance test, repetitive function test and STO revalidation test:

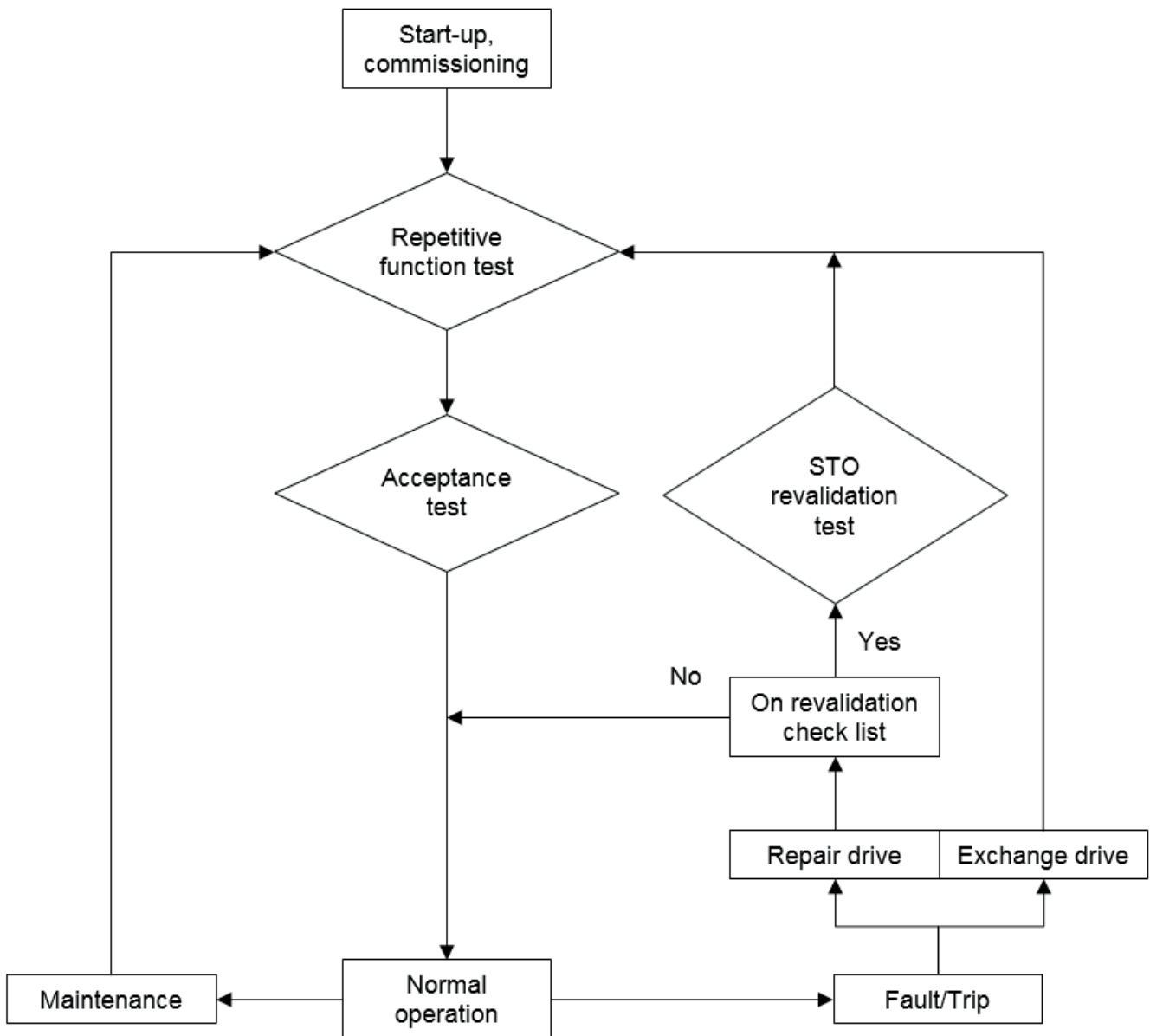

Figure 8 "Acceptance test, repetitive function test and STO revalidation test"

Maintenance

The STO function shall be maintained by periodic testing. To perform the maintenance, do the following:

- Repetitive function test.
- Acceptance test.

Fault/Trip

If the drive was repaired and the changed hardware is not in the revalidation check list below, no test is needed. After a fault/trip, depending on the type of repair, the STO function shall be tested.

If the complete drive module has been exchanged, do the following:

- Repetitive function test.
- Acceptance test.

If the drive was repaired and the changed hardware is in the revalidation check list below, do the following:

- STO revalidation test (subject to service manual).
- Repetitive function test.
- Acceptance test.

Acceptance test

Action	<input checked="" type="checkbox"/>
 Warning! Follow the Safety instructions, Ignoring the instructions can cause physical injury or death, or damage to the equipment.	<input type="checkbox"/>
Ensure that the drive can be run and stopped freely during start-up.	<input type="checkbox"/>
Stop the drive (if running), switch off mains- and auxiliary power and isolate the drive from the power lines by disconnectors.	<input type="checkbox"/>
Check the STO circuit connections against the wiring diagram.	<input type="checkbox"/>
Close the disconnectors and switch on mains- and auxiliary power.	<input type="checkbox"/>
Test the operation of the STO function when the motor is stopped. <ul style="list-style-type: none"> • Give a stop command for the drive (if running) and wait until the motor shaft is at a standstill. • Ensure that the drive operates as follows: <ul style="list-style-type: none"> - Open the STO circuit. The drive generates an indication if one is defined for 'stopped' state in 31.22 STO indication run/stop (see DCS880 Firmware Manual). - Give a start command to verify that the STO function blocks the drive operation. The motor should not generate torque. - Close the STO circuit. - Reset any active faults. Restart the drive and check that the motor runs normally. 	<input type="checkbox"/>
Test the operation of the STO function when the motor is running. <ul style="list-style-type: none"> • Start the drive and ensure the motor is running. • Ensure that the drive operates as follows: <ul style="list-style-type: none"> - Open the STO circuit. The motor should stop (coast) and should not generate torque. The drive generates an indication if one is defined for 'running' state in 31.22 STO indication run/stop (see DCS880 Firmware Manual). - Reset any active faults and try to start the drive. - Ensure that the motor stays at standstill and the drive operates as described above in testing the operation when the motor is stopped. - Close the STO circuit. - Reset any active faults. Restart the drive and check that the motor runs normally. 	<input type="checkbox"/>
Only for frame size H7 and H8 Test the operation of the failure detection of the drive. The motor can be stopped or running. <ul style="list-style-type: none"> • Open the 1st optical channel of the STO circuit (optical cable connected to DSL-H12 / H14 v12). If the motor was running, it should coast to a stop. The drive generates fault "STO Stuck at with aux code" (see DCS880 Firmware Manual). • Give a start command to verify that the STO function blocks the drive's operation. The motor should not generate torque. • Close the STO circuit. • Reset any active faults. Restart the drive and check that the motor runs normally. • Open the 2nd optical channel of the STO circuit (optical cable connected to DSL-H12 / H14 v11). If the motor was running, it should coast to a stop. The drive generates fault "STO Stuck at with aux code" (see DCS880 Firmware Manual). • Give a start command to verify that the STO function blocks the drive's operation. The motor should not generate torque. • Close the STO circuit. • Reset any active faults. Restart the drive and check that the motor runs normally. 	<input type="checkbox"/>
Test the operation of the failure detection of the drive. The motor can be stopped or running. <ul style="list-style-type: none"> • Open the 1st channel of the STO circuit (wire connected to XSTO:IN1). If the motor was running, it should coast to a stop. The drive generates fault FA81 Safe torque off 1 loss (see DCS880 Firmware Manual). • Give a start command to verify that the STO function blocks the drive's operation. The motor should not generate torque. • Close the STO circuit. • Reset any active faults. Restart the drive and check that the motor runs normally. • Open the 2nd channel of the STO circuit (wire connected to XSTO:IN2). If the motor was running, it should coast to a stop. The drive generates fault FA82 Safe torque off 2 loss (see DCS880 Firmware Manual). • Give a start command to verify that the STO function blocks the drive's operation. The motor should not generate torque. • Close the STO circuit. • Reset any active faults. Restart the drive and check that the motor runs normally. 	<input type="checkbox"/>
Document and sign the acceptance test which verifies that the safety function is safe and accepted for operation in the machine log book.	<input type="checkbox"/>

Repetitive function test

Action	<input checked="" type="checkbox"/>
 Warning! Follow the Safety instructions, Ignoring the instructions can cause physical injury or death, or damage to the equipment.	<input type="checkbox"/>
Ensure that the drive can be run and stopped freely during start-up.	<input type="checkbox"/>
Stop the drive (if running), switch off mains- and auxiliary power and isolate the drive from the power lines by disconnectors.	<input type="checkbox"/>
Check the XSMC circuit connections against the wiring diagram.	<input type="checkbox"/>
Switch on mains- and auxiliary power and close the disconnectors.	<input type="checkbox"/>
Set 31.22 STO indication run/stop = No indication/No indication.	<input type="checkbox"/>
Close the STO terminal circuit	<input type="checkbox"/>
Reset any active faults. Restart the drive and check that the motor runs normally.	<input type="checkbox"/>
Increase set point of the machine until 06.24 Current controller status word 1: <ul style="list-style-type: none"> • 06.24.b09 = 0 = Drive is motoring. • 06.24.b12 = 0 = Discontinuous armature current (recommendation not mandatory). • 06.24.b13 = 0 = Armature current not zero. 	<input type="checkbox"/>
Set 31.100 STO Test mode = No Block.	<input type="checkbox"/>
Open the STO terminal circuit. XSTO:IN1 and XSTO:IN2	<input type="checkbox"/>
After load switching element has opened or after 1s	<input type="checkbox"/>
Remove the run command	<input type="checkbox"/>
Set 31.100 STO Test mode back to None.	<input type="checkbox"/>
Give a reset command to the drive	<input type="checkbox"/>
Drive must show fault 5093 Safe off main contactor XSMCSTO.	<input type="checkbox"/>
It will also show fault 5092 STO overall fault.	<input type="checkbox"/>
Compare the values of 31.94 STO time 1 and 31.95 STO time 2. Their values must be within ± 50 ms of 300 ms.	<input type="checkbox"/>
Relay XSMC:STO (3, 4) on the SDCS-CON-H01 must have been opened.	<input type="checkbox"/>
The load switching element e.g. a mains contactor (MC), an air circuit breaker (ACB), a DC breaker (DCB) or a high speed DC breaker (HSDCB) connected to XSMC:STO must have been opened.	<input type="checkbox"/>
The control board must be rebooted (cycle auxiliary power) afterwards, as relay XSMC:STO is only closed once during the boot of the drive.	<input type="checkbox"/>
Test the function of connector XSMC when the motor is stopped. <ul style="list-style-type: none"> • Give a stop command for the drive (if running) and wait until the motor shaft is at a standstill. • Ensure that the drive operates as follows: • Unplug connector XSMC. • Give a start command. The motor should not generate torque. The used load switching device, e.g. a mains contactor (MC), an air circuit breaker (ACB), a DC breaker (DCB) or a high speed DC breaker (HSDCB) must stay open. • Re-plug connector XSMC. (Attention high voltage) 	<input type="checkbox"/>
Reset any active faults. Restart the drive and check that the motor runs normally.	<input type="checkbox"/>
If changed set 31.22 STO indication run/stop back to original value	<input type="checkbox"/>
Document and sign the repetitive function test which verifies that the fault shutdown path of the safety function is safe and accepted for operation in the machine log book.	<input type="checkbox"/>

—

Languages:

- English (original document)



- Spanish



- German



- Polish



- Italien



- Swedish



- Russian



- French



- Danish



- Turkish



—

ABB Automation Products GmbH
Motors and Drives
Wallstadter Straße 59
D-68526 Ladenburg
Germany
www.abb.com/dc-drives
www.abb.com/drivespartners

