

ACS355 drives

Quick installation and start-up guide

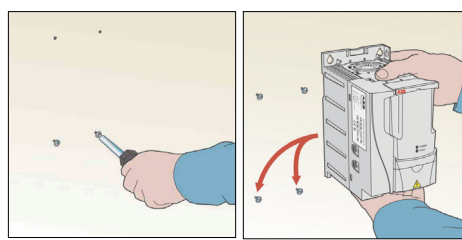

- Start to tighten the screws into the mounting holes.
- Place the drive onto the mounting screws.
- Tighten the mounting screws securely.



To install the drive to a DIN rail

- Place the top of the drive onto the DIN installation rail in an angle as shown in figure.
- Set the drive against the wall.
- To remove the drive, press the release lever on top of the drive.

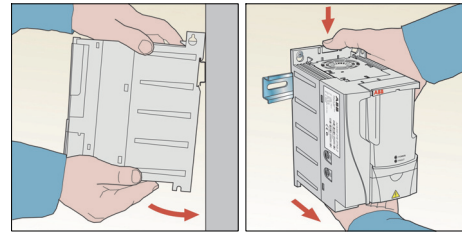

3. Attach the clamping plates

- Fasten the clamping plate to the plate at the bottom of the drive with the provided screws.
- Frame sizes R0...R2:** Fasten the I/O clamping plate to the clamping plate with the provided screws.

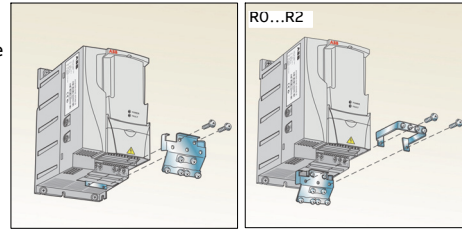

4. Measure the insulation resistance

Measuring the insulation is typically not required in North America.

Drive: Do not do voltage tolerance or insulation resistance tests on the drive, because this can cause damage to the drive.

Input power cable: Before you connect the input power cable, measure the insulation of the input power cable. Obey the local regulations.

Motor and motor cable:

- Make sure that the motor cable is connected to the motor and disconnected from the drive output terminals U2, V2 and W2.
- Use a voltage of 1000 V DC to measure the insulation resistance between each phase conductor and the protective earth conductor. The insulation resistance of an ABB motor must be more than 100 Mohm (at 25 °C/77 °F). For the insulation resistance of other motors, refer to the manufacturer's documentation. Moisture in the motor decreases the insulation resistance. If you think that there is moisture in the motor, dry the motor and do the measurement again.

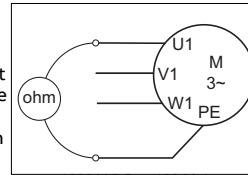

5. Select the cables

Input power cable: IEC/EN 61800-5-1 requires two protective earth (ground) conductors. Prefer a symmetrical shielded cable (VFD cable).

Motor cable: Use a symmetrical shielded cable (VFD cable) for the best EMC performance and to meet the European EMC requirements.

Control cable: Use a double-shielded twisted-pair cable for analog signals. Use a double- or single-shielded cable for digital, relay and I/O signals. Do not mix 24 V and 115/230 V signals in the same cable.

6. Connect the power cables

Connection diagram (shielded cables)

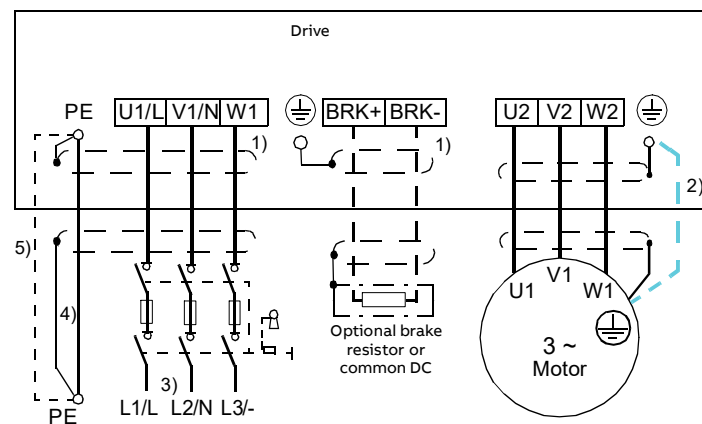

- 360-degree grounding of the cable shield. Required for the motor cable and brake resistor cable, recommended for the input power cable.
- Use a separate grounding cable if the conductivity of the cable shield is not sufficient (smaller than the conductivity of the phase conductor) for the protective grounding, or there is no symmetrically constructed grounding conductor in the cable.
- In one-phase installations, connect phase to U1/L, neutral to V1/N and leave W1 disconnected.
- Use two grounding conductors if the cross-section of a single grounding conductor is less than 10 mm² Cu or 16 mm² Al (IEC/EN 61800-5-1). For example, use the cable shield in addition to the fourth conductor.
- Use a separate grounding cable (line side) if the conductivity of the fourth conductor or shield is not sufficient for the protective grounding.

Connection procedure (shielded cables)

WARNING! Make sure that the drive is compatible with the earthing system. You can connect all drive types to a symmetrically grounded TN-S system. For other systems, see the drive user's manual.

- Strip the input power cable. Ground the cable shield (if any) under the grounding clamp. Twist the cable shield into a bundle, mark it accordingly and connect it to the grounding terminal. Connect other grounding conductors (PE) to the grounding terminal. Connect the phase conductors to the U1, V1 and W1 terminals.
- Strip the motor cable. Ground the cable shield under the grounding clamp. Twist the motor cable shield into a bundle, mark it accordingly and connect it to the grounding terminal. Connect the phase conductors to the U2, V2 and W2 terminals.
- If applicable, connect the brake resistor cable to the BRK+ and BRK- terminals. Use a shielded cable and ground the shield under the grounding clamp.
- Mechanically attach the cables on the outside of the drive.

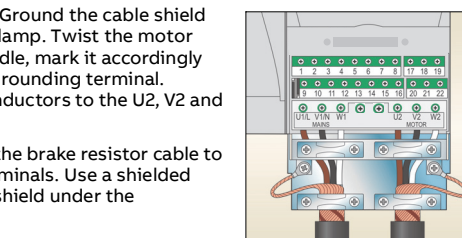
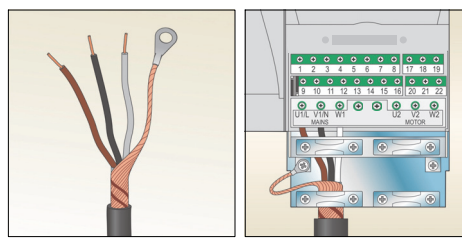

Frame size	Tightening torques	
	U1, V1, W1, U2, V2, W2, BRK+ and BRK-	PE
R0...R2	0.8 N·m (7 lbf·in)	1.2 N·m (11 lbf·in)
R3	1.7 N·m (15 lbf·in)	1.2 N·m (11 lbf·in)
R4	2.5 N·m (22 lbf·in)	1.2 N·m (11 lbf·in)

00353783 L

7. Connect the control cables

Default I/O connections

The diagram shows the I/O connections when parameter 9902 has value 1 (ABB STANDARD).

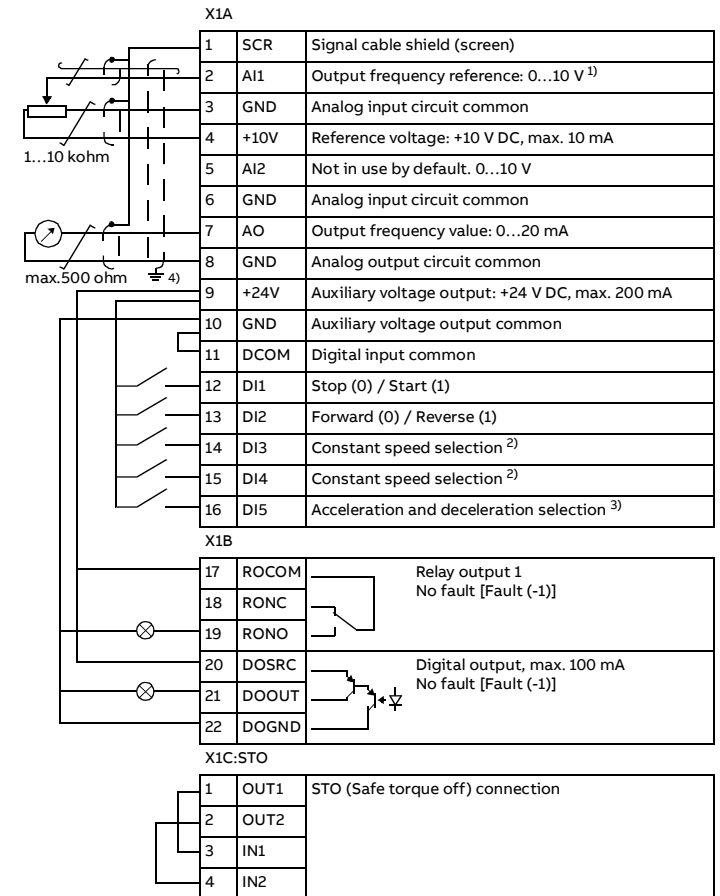

¹⁾ AI1 is used as a speed reference if vector mode is selected.

²⁾ See parameter group 12 CONSTANT SPEEDS:

D13	D14	Operation (par.)
0	0	Set speed through AI1
1	0	Speed 1 (I202)
0	1	Speed 2 (I203)
1	1	Speed 3 (I204)

³⁾ 0 = ramp times according to parameters 2202 and 2203. 1 = ramp times according to parameters 2205 and 2206.

⁴⁾ 360 degree grounding under a clamp.

Tightening torque: 0.4 N·m / 3.5 lbf·in.

Connection procedure

To prevent inductive coupling, keep the signal wire pairs twisted all the way up to the terminals.

- Remove the terminal cover.
- Strip the outer insulation of the cable and ground the bare shield 360 degrees under the clamp.
- Connect the conductors to the correct control terminals. Torque the terminals to 0.4 N·m (3.5 lbf·in).
- For double-shielded cables, twist also the grounding conductors of each pair in the cable together and connect the bundle to the SCR terminal (terminal 1).
- Mechanically attach the control cables on the outside of the drive.
- If you are going to use an optional Safe Torque Off function, connect STO conductors to the correct terminals. Use a tightening torque of 0.4 N·m (3.5 lbf·in).
- Unless you need to install the optional fieldbus module, slide the terminal cover back into place.

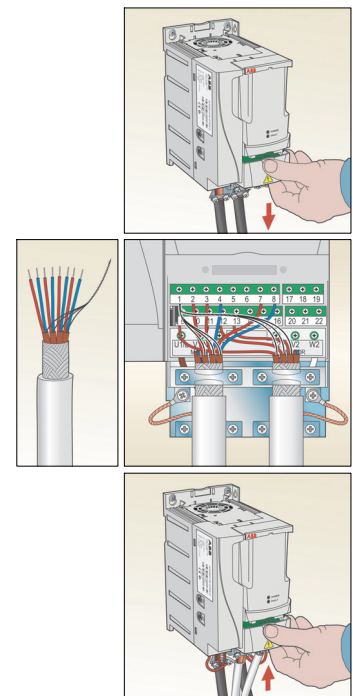

8. Install the fieldbus module (optional)

See the drive user's manual.

9. Install the control panel (if any)

10. Start up the drive

WARNING! Before you start up the drive, make sure that the installation is complete. Make sure that the cover of the drive is in place. Make sure also that the motor does not cause danger when it starts. Disconnect the motor from other machinery, if there is a risk of damage or injury. There is an extensive installation checklist in the drive user's manual.

Start up without a control panel

- Apply input power and wait for a moment.
- Check that the red LED is not lit and the green LED is lit but not blinking.

The drive is now ready for use.

Start up with a control panel (manual start-up)

You can use the basic control panel or the assistant control panel. The instructions below are valid for both control panels, but the displays shown are the basic control panel displays, unless the instruction applies to the assistant control panel only.

Before you start, ensure that you have the motor nameplate data at hand.

POWER-UP	
<input type="checkbox"/> Apply input power. The basic control panel powers up into the Output mode.	REM OUTPUT 0.0 Hz FWD
The assistant control panel asks if you want to run the Start-up assistant. If you press ENT , the Start-up assistant is not run, and you can continue with manual start-up in a similar manner as described below for the basic control panel.	REM CHOICE Do you want to use the start-up assistant? Yes NO
	EXIT 00:00 OK

Safety instructions

WARNING! Obey these instructions. If you ignore them, injury or death, or damage to the equipment can occur. If you are not a qualified electrical professional, do not do electrical installation or maintenance work.

- Keep the drive in its package until you install it. After unpacking, protect the drive from dust, debris and moisture.
- Use the required personal protective equipment: safety shoes with metal toe cap, safety glasses, protective gloves and long sleeves, etc.
- When the drive or connected equipment is energized, do not do work on the drive, motor cable, motor, control cables or control circuits.
- Do not do work on the drive when a rotating permanent magnet motor is connected to it. A rotating permanent magnet motor energizes the drive, including its input and output power terminals.

Electrical safety precautions

- Clearly identify the work location and equipment.
- Disconnect all possible voltage sources. Make sure that re-connection is not possible. Lock out and tag out.
 - Open the main disconnecting device of the drive.
 - If you have a permanent magnet motor connected to the drive, disconnect the motor from the drive.
 - Disconnect any dangerous external voltages from the control circuits.
 - After you disconnect power from the drive, always wait 5 minutes to let the intermediate circuit capacitors discharge before you continue.
- Protect any other energized parts in the work location against contact.
- Take special precautions when close to bare conductors.
- Measure that the installation is de-energized.
 - Use a multimeter with a minimum impedance of 1 Mohm.
 - Make sure that the voltage between the drive input power terminals (U1, V1, W1) and the ground (PE) is close to 0 V.
 - Make sure that the voltage between the drive output terminals (U2, V2, W2) and the ground (PE) is close to 0 V.
 - Make sure that the voltage between the drive DC terminals (BRK+ and BRK-) and the ground (PE) is close to 0 V.
- Install temporary grounding as required by the local regulations.
- Ask the person in control of the electrical installation work for a permit to work.

See the drive user's manual for the complete safety instructions.

1. Examine the installation area

The drive is intended for cabinet installation and has a degree of protection of IP20 / UL open type as standard.

Make sure that in the installation area:

- There is sufficient space above and below the drive for cooling, and hot air does not recirculate. Refer to [Free space requirements](#).
- The ambient conditions are suitable. Refer to [Ambient conditions](#).
- The mounting surface is non-flammable and can hold the weight of the drive. Refer to [Dimensions and weights](#).
- Materials near the drive are non-flammable.
- There are no sources of strong magnetic fields, such as high-current single-core conductors or contactor coils near the drive. A strong magnetic field can cause interference in the operation of the drive.

2. Install the drive

You can install the drive with screws or to a DIN rail [Top Hat, W x H = 35 x 7.5 mm (1.4 x 0.3 in)].

- Make sure that there is a minimum of 75 mm (3 in) of free space above and below the drive for cooling air.
- When placing drives on top of each other in a panel or cabinet, make sure that the hot air from the drives below do not directly enter the drive above.

WARNING! Do not install the drive upside down. Make sure that the cooling air exhaust (at the top) is above the cooling air inlet (at the bottom).

To install the drive with screws

- Cut out the mounting template from the package and use it to mark the locations for the mounting holes.
- Make the holes for the mounting screws and install suitable plugs or anchors.

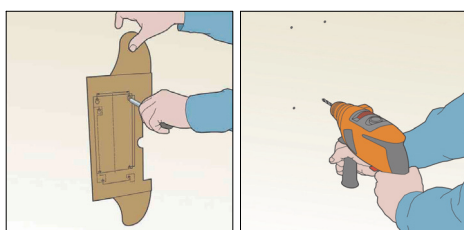

ENTRY OF START-UP DATA (parameter group 99)

If you have an assistant control panel, select the language. See parameter 9901 for the values of the available language alternatives.

Select the motor type (9903).
1 (AM): Asynchronous motor
2 (PMSM): Permanent magnet synchronous motor.

Setting of parameter 9903 is shown below as an example of parameter setting with the basic control panel.

1. To go to the Main menu, press if the bottom line shows OUTPUT; otherwise press repeatedly until you see MENU at the bottom.

2. Press keys until you see "PAR".

3. Press . Panel changes to Parameter mode. The display shows the number of one of the parameter groups.

4. Find the appropriate parameter group (99) with keys .

5. Press . The display shows one of the parameters in the selected group. Find the appropriate parameter (9903) with keys .

6. Press and hold for about two seconds until parameter value is shown with SET under the value. If necessary, change the value with keys .

7. Save the parameter value by pressing .

Select the application macro (9902) according to how the control cables are connected. The default value 1 (ABB STANDARD) is suitable in most cases.

Select the motor control mode (9904).
1 (VECTOR: SPEED) suits most cases
2 (VECTOR: TORQ) suits torque control
3 (SCALAR: FREQ) suits if control accuracy is not important, and for certain special cases. See user's manual. Not for permanent magnet synchronous motors.

Enter the motor data from the motor nameplate: motor nominal voltage (9905), nominal motor current (9906), motor nominal frequency (9907), motor nominal speed (9908), motor nominal power (9909).

Select the motor identification method (9910). The default value 0 (OFF/IDMAGN) using the identification magnetization is suitable for most applications. It is applied here. (Requires also that 9904 is set to 1 (VECTOR: SPEED) or 2 (VECTOR: TORQ)).

IDENTIFICATION MAGNETIZATION WITH ID RUN SELECTION 0 (OFF/IDMAGN)

Press key to switch to local control (LOC shown on the left). Press to start the drive. The motor model is now calculated by magnetizing the motor for 10 to 15 s at zero speed.

DIRECTION OF THE MOTOR ROTATION

Check the direction of the motor rotation.
1. If the drive is in remote control (REM shown on the left), switch to local control by pressing .

2. To go to the Main menu, press if the bottom line shows OUTPUT; otherwise press repeatedly until you see MENU at the bottom.

3. Press keys until you see "rEF" and press .

4. Increase the frequency reference from zero to a small value with key .

5. Press to start the motor.

6. Check that the actual direction of the motor is the same as indicated on the display (FWD means forward and REV reverse).

7. Press to stop the motor.

To change the forward and reverse rotation directions (with a parameter):
Invert the phases by changing the value of parameter 9914 to the opposite, ie, from 0 (NO) to 1 (YES), or vice versa.
Verify your work by repeating the rotation direction check as described above.

SPEED LIMITS AND ACCELERATION/DECELERATION TIMES

Set the minimum speed (2001), maximum speed (2002), acceleration time 1 (2202), and deceleration time 1 (2203).

SAVING A USER MACRO AND FINAL CHECK

The start-up is now completed. If you want to save your setting as a user macro, scroll to Parameter 9902 and select value USER S1 SAVE.

Check that there are no faults or alarms shown on the display.

The drive is now ready for use.

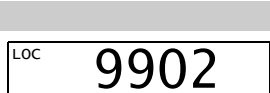
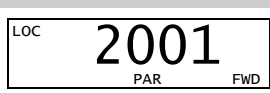
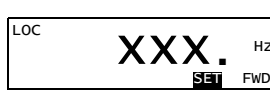
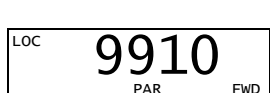
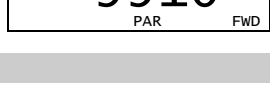
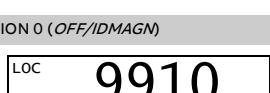
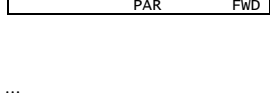
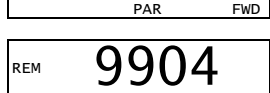
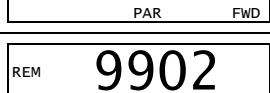
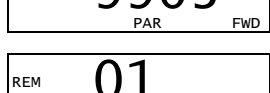
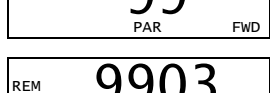
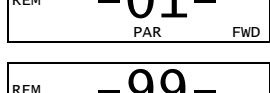
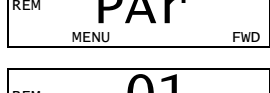
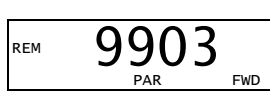
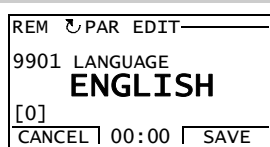

Fault codes

This is a short list of fault messages.

Fault	Description
0001	OVERCURRENT - Output current has exceeded trip level.
0002	DC OVERVOLT - Excessive intermediate circuit DC voltage.
0003	DEV OVERTEMP - Drive IGBT temperature is excessive.
0004	SHORT CIRC - Short-circuit in motor cable(s) or motor.
0006	DC UNDERVOLT - Intermediate circuit DC voltage is not sufficient.
0009	MOT OVERTEMP - Motor temperature estimation is too high.
0016	EARTH FAULT - Drive has detected earth (ground) fault in motor or motor cable.
0022	SUPPLY PHASE - Intermediate circuit DC voltage is oscillating due to missing input power line phase or blown fuse.
0044	SAFE TORQUE OFF - STO (Safe torque off) requested via STO terminal and it functions correctly. Parameter 3025 STO OPERATION is set to react with fault.

Ratings

ACS355-... x = E/U	Input		Input with choke		Output					Frame size
	I _N	I _N (480 V)	I _N	I _N (480 V)	I _{2N}	I _{2,1/10}	I _{2max}	P _N	kW	
1-phase U _N = 230 V (200...240 V)										
01x-02A4-2	6.1	-	4.5	-	2.4	3.6	4.2	0.37	0.5	R0
01x-04A7-2	11	-	8.1	-	4.7	7.1	8.2	0.75	1	R1
01x-06A7-2	16	-	11	-	6.7	10.1	11.7	1.1	1.5	R1
01x-07A5-2	17	-	12	-	7.5	11.3	13.1	1.5	2	R2
01x-09A8-2	21	-	15	-	9.8	14.7	17.2	2.2	3	R2
3-phase U _N = 230 V (200...240 V)										
03x-02A4-2	4.3	-	2.2	-	2.4	3.6	4.2	0.37	0.5	R0
03x-03A5-2	6.1	-	3.5	-	3.5	5.3	6.1	0.55	0.75	R0
03x-04A7-2	7.6	-	4.2	-	4.7	7.1	8.2	0.75	1	R1
03x-06A7-2	12	-	6.1	-	6.7	10.1	11.7	1.1	1.5	R1
03x-07A5-2	12	-	6.9	-	7.5	11.3	13.1	1.5	2	R1
03x-09A8-2	14	-	9.2	-	9.8	14.7	17.2	2.2	3	R2
03x-13A3-2	22	-	13	-	13.3	20.0	23.3	3	3	R2
03x-17A6-2	25	-	14	-	17.6	26.4	30.8	4	5	R2
03x-24A4-2	41	-	21	-	24.4	36.6	42.7	5.5	7.5	R3
03x-31A0-2	50	-	26	-	31	46.5	54.3	7.5	10	R4
03x-46A2-2	69	-	41	-	46.2	69.3	80.9	11.0	15	R4
3-phase U _N = 400/480 V (380...480 V)										
03x-01A2-4	2.2	1.8	1.1	0.9	1.2	1.8	2.1	0.37	0.5	R0
03x-01A9-4	3.6	3.0	1.8	1.5	1.9	2.9	3.3	0.55	0.75	R0
03x-02A4-4	4.1	3.4	2.3	1.9	2.4	3.6	4.2	0.75	1	R1
03x-03A3-4	6.0	5.0	3.1	2.6	3.3	5.0	5.8	1.1	1.5	R1
03x-04A1-4	6.9	5.8	3.5	2.9	4.1	6.2	7.2	1.5	2	R1
03x-05A6-4	9.6	8.0	4.8	4.0	5.6	8.4	9.8	2.2	3	R1
03x-07A3-4	12	9.7	6.1	5.1	7.3	11.0	12.8	3	3	R1
03x-08A8-4	14	11	7.7	6.4	8.8	13.2	15.4	4	5	R1
03x-12A5-4	19	16	11	9.5	12.5	18.8	21.9	5.5	7.5	R3
03x-15A6-4	22	18	12	10	15.6	23.4	27.3	7.5	10	R3
03x-23A1-4	31	26	18	15	23.1	34.7	40.4	11	15	R3
03x-31A0-4	52	43	25	20	31	46.5	54.3	15	20	R4
03x-38A0-4	61	51	32	26	38	57	66.5	18.5	25	R4
03x-44A0-4	67	56	38	32	44	66	77.0	22.0	30	R4

I_N continuous rms input current (for dimensioning cables and fuses)
I_N (480 V) continuous rms input current (for dimensioning cables and fuses) for drives with 480 V input voltage
I_{2N} continuous rms current. 50% overload is allowed for one minute every ten minutes.
I_{2,1/10} maximum (50% overload) current allowed for one minute every ten minutes
I_{2max} maximum output current. Available for two seconds at start, otherwise as long as allowed by the drive temperature.
P_N typical motor power. The kilowatt ratings apply to most IEC 4-pole motors. The horsepower ratings apply to most NEMA 4-pole motors.

Fuses and typical power cable sizes

The table list the fuses for protection against short-circuits in the input power cable or drive. The table also shows typical power cable sizes.

ACS355-... x = E/U	Fuses		Size of copper conductor					
	gG	UL Class T or CC (600 V)	Supply (U1, V1, W1)		Motor (U2, V2, W2)		PE (BRK+, BRK-)	
	A	A	mm ²	AWG	mm ²	AWG	mm ²	AWG
1-phase U _N = 230 V (200...240 V)								
01x-02A4-2	10	10	2.5	14	0.75	18	2.5	14
01x-04A7-2	16	20	2.5	14	0.75	18	2.5	14
01x-06A7-2	16/20 ¹⁾	25	2.5	10	1.5	14	2.5	10
01x-07A5-2	20/25 ¹⁾	30	2.5	10	1.5	14	2.5	10
01x-09A8-2	25/35 ¹⁾	35	6	10	2.5	12	6	10
3-phase U _N = 230 V (200...240 V)								
03x-02A4-2	10	10	2.5	14	0.75	18	2.5	14
03x-03A5-2	10	10	2.5	14	0.75	18	2.5	14
03x-04A7-2	10	15	2.5	14	0.75	18	2.5	14
03x-06A7-2	16	15	2.5	12	1.5	14	2.5	12
03x-07A5-2	16	15	2.5	12	1.5	14	2.5	12
03x-09A8-2	16	20	2.5	12	2.5	12	2.5	12
03x-13A3-2	25	30	6	10	6	10	6	10
03x-17A6-2	25	35	6	10	6	10	6	10
03x-24A4-2	63	60	10	8	10	8	6	10
03x-31A0-2	80	80	16	6	16	6	16	6
03x-46A2-2	100	100	25	2	25	2	16	4
3-phase U _N = 400/480 V (380...480 V)								
03x-01A2-4	10	10	2.5	14	0.75	18	2.5	14
03x-01A9-4	10	10	2.5	14	0.75	18	2.5	14
03x-02A4-4	10	10	2.5	14	0.75	18	2.5	14
03x-03A3-4	10	10	2.5	12	0.75	18	2.5	12
03x-04A1-4	16	15	2.5	12	0.75	18	2.5	12
03x-05A6-4	16	15	2.5	12	1.5	14	2.5	12
03x-07A3-4	16	20	2.5	12	1.5	14	2.5	12
03x-08A8-4	20	25	2.5	12	2.5	12	2.5	12
03x-12A5-4	25	30	6	10	6	10	6	10
03x-15A6-4	35	35	6	8	6	8	6	8
03x-23A1-4	50	50	10	8	10	8	6	10
03x-31A0-4	80	80	16	6	16	6	16	6
03x-38A0-4	100	100	16	4	16	4	16	4
03x-44A0-4	100	100	25	4	25	4	16	4

¹⁾ If 50% overload capacity is needed, use the larger fuse alternative.

Ambient conditions

Requirement	During operation (installed for stationary use)
Installation altitude	0...2000 m (0...6562 ft) above sea level (with output derating above 1000 m [3281 ft])
Surrounding air temperature	-10...+50 °C (14...122 °F). If the temperature is more than 40 °C (104 °F), output derating is necessary. No frost permitted.
Relative humidity	0...95% without condensation

Requirement	During operation (installed for stationary use)
Contamination levels (IEC 60721-3-3: 2002)	No conductive dust permitted
Shock (IEC 60068-2-27, IATA 1A)	Not permitted
Free fall	Not permitted

Dimensions and weights

IP20 (cabinet) / UL open												
Frame size	H1		H2		H3		W		D		Weight	
	mm	in	mm	in	mm	in	mm	in	mm	in	kg	lb
R0	169	6.65	202	7.95	239	9.41	70	2.76	161	6.34	1.2	2.6
R1	169	6.65	202	7.95	239	9.41	70	2.76	161	6.34	1.4	3.0
R2	169	6.65	202	7.95	239	9.41	105	4.13	165	6.50	1.8	3.9
R3	169	6.65	202	7.95	236	9.29	169	6.65	169	6.65	3.1	6.9
R4	181	7.13	202	7.95	244	9.61	260	10.24	169	6.65	5.2	11.5

IP20 / NEMA 1										
Frame size	H4		H5		W		D		Weight	
	mm	in	mm	in	mm	in	mm	in	kg	lb