

DCS880

Hardware manual DCS880 Drives (20 ... 5200 A)



DCS880 Drive manuals

	Publication number	Language						
		E	D	I	ES	F	CN	RU
General								
DCS880 Quick guide	3ADW000480	x						
Safety instructions all languages	3ADW000481	x	x	x	x	x	x	x
DCS880 Documentation pack	 DCS880 CD download	x						
DCS880 Units								
DCS880 Flyer	3ADW000475	x	x			x		
DCS880 Technical catalog	3ADW000465	x						
DCS880 Hardware manual	3ADW000462	x						
DCS880 Firmware manual	3ADW000474	x						
DCS880 Service manual	3ADW000488	x						
DCS880 Hardparallel manual	3ADW000530							
DCS880 12-pulse manual	3ADW000533							
Instructions for mounting the SDCS-CMA-2	3ADW000396							
ACS-AP-x assistant control panels user's manual	3AUA0000085685	x						
Functional safety								
Supplement for functional safety	3ADW000452	x						
Functional safety for enclosed converter								
+Q957 Prevention of unexpected Start Up	3ADW000504	x						
+Q951 Emergency stop, category 0 with MC	3ADW000505	x						
+Q952 Emergency stop, category 1 with MC	3ADW000506	x						
+Q963 Emergency stop, category 0 without MC	3ADW000507	x						
+Q964 Emergency stop, category 1 without MC	3ADW000508	x						
Enclosed converter								
Installation manual	3ADW000352	x						
DCS800-A + S880 Enclosed converters, flyer	3ADW000523	x						
Door mounting kits								
DPMP-01 mounting platform for ACS-AP control panel	3AUA0000100140	x						
DPMP-02 mounting platform for ACS-AP control panel	3AUA0000136205	x						
Serial communication								
FCAN-01 CANopen adapter module	3AFE68615500	x	x					
FDNA-01 DeviceNet™ adapter module	3AFE68573360	x						
FECA-01 EtherCAT adapter module	3AUA0000068940	x	x					
FENA-11/-21 Ethernet adapter module	3AUA0000093568	x						
FEPL-02 Ethernet POWERLINK adapter module	3AUA0000123527	x	x					
FPBA-01 PROFIBUS DP adapter module	3AFE68573271	x	x					
FSCA-01 RS-485 adapter module	3AUA0000109533	x						
FDCO-01/02 DDCS communication modules	3AUA0000114058							
Tool and maintenance manuals and guides								
Drive composer PC tool	3AUA0000094606	x						
Drive (IEC61131-3) application programming manual	3AUA0000127808	x						
Adaptive programming, Application guide	3AXD50000028574	x						
NETA-21 remote monitoring tool	3AUA0000096939	x						
NETA-21 remote monitoring tool guide	3AUA0000096881	x						
DDCS branching units NBDU-85, NBDU-95	3BFE64285513	x						
Extension modules								
FIO-11 Analog extension module	3AFE68784930	x						
FIO-01 Digital extension modules	3AFE68784921	x						
FAIO-01 Analog extension module	3AUA0000124968	x						
FDIO-01 Digital extension module	3AUA0000124966	x						
FEN-01 TTL encoder interface	3AFE68784603	x						
FEN-31 HTL encoder interface	3AUA0000031044	x						
FEA-03 F series extension adapter	3AUA0000115811	x						
Ethernet tool network for ACS880 drives	3AUA0000125635	x						

DCS880 Drives 20 ... 5200 A

Hardware manual

Code: 3ADW000462R0401 Rev D

Effective: 01.2019

Supersedes: 01.2018

© 2019 ABB Automation Products GmbH. All rights reserved.

Table of contents

DCS880 Drive manuals	2
----------------------------	---

Table of contents

Safety instructions

What this chapter contains	9
To which products this chapter applies	9
Use of warnings and notes	9
Installation and maintenance work	10
Grounding	11
Printed circuit boards and fiber optic cables	12
Mechanical installation	12
Operation	13

The DCS880

Chapter overview	14
The DCS880 converter modules	14
Type code	15
Plus codes	16
Main circuit and control	17
Armature converter DCS880 H1 ... H4	17
Armature converter DCS880 H5	18
Armature converter DCS880 H6	19
Armature converter DCS880 H7 and H8	20

Mechanical installation

Chapter overview	21
Safety	21
Examining the installation site	21
Necessary tools	21
Moving the drive	21
Unpacking and examining the delivery (H1 ... H3)	22
Unpacking and examining the delivery (H4)	23
Unpacking and examining the delivery (H5)	24
Unpacking and examining the delivery (H6)	25
Unpacking and examining the delivery (H7, H8)	26
Delivery check	27
Installing the drive (H1 ... H3)	29
Installing the drive (H4, H5)	30
Installing the drive (H6 ... H8)	31
Cabinet installation	31
Preventing cooling air recirculation	31

Unit above another	31
Terminal options for converter modules size H1 ... H4	32
Connection of H4 converter module DC terminals	32
Terminal cover according to VBG 4 regulations (H1 ... H4 only)	32
Mounting the converter module H5 inside an enclosure	34
Mounting the H7 power unit inside an enclosure	35
Mounting the H8 power unit inside an enclosure	36

Planning the electrical installation

Chapter overview	37
Options	37
Line reactors (L1)	37
Semiconductor fuses (F1)	40
Semiconductor fuses (F1) and fuse holders for armature circuit	41
Fuses (F3.x) and fuse holders for field circuit	42
Single-phase autotransformer (T3) for field circuit (adapt voltage)	43
Line reactors for single- and 3-phase connection of field converters	44
Auxiliary transformer (T2) for electronic system / fan supply	44
EMC filters (E1)	45
Converters size H1 ... H4 configuration using an OnBoard field exciter	48
Converters size H5 configuration using FEX-425-Int field exciter	49
Converters size H6 configuration using a FEX-425-Int field exciter	50
Converters size H1 ... H6 configuration using external field exciters DCF803, DCF804	51
Converters size H7 and H8 configuration using external field exciters DCF803, DCF804	52
Converters size H1 ... H3 as large field exciter	53
Start, Stop and E-Stop control	54
Cooling fans	56
Fan connection for DCS880 (H1 ... H4)	57
Fan connection for DCS880 (H5 ... H8)	58
Monitoring the DCS880 power section	59
Implementing thermal overload and short-circuit protection	59
Cross-sectional areas - Tightening torques	61
Selecting the power cables	62
Connection of a motor temperature sensor to the drive I/O	64

Electrical installation

Chapter overview	65
Checking the insulation of the drive	65
IT (ungrounded) systems	66
Supply voltage	66
Connecting the power cables	66
Location F-type adapters and interfaces	67
FEA-03 I/O extension adapter configuration	68
Pulse encoder connection	69
Pulse encoder connection principles	70
Connecting the signal and control cables	72
Routing the cables	72
DCSLink wiring	73

Connecting a control unit at H7 and H8 power units	76
--	----

Installation checklist

Maintenance

Chapter overview	78
Safety	78

Technical data

Chapter overview	79
Environmental Conditions	79
Current ratings - IEC regenerative converters (S02)	81
Current ratings - IEC non regenerative converters (S01)	82
Standard duty cycles	82
Control board SDCS-CON-H01 (H1 ... H8)	83
Location of the control circuit board SDCS-CON-H01	83
Watchdog function	83
Recommended wire size - Tightening torques	83
Intermediate cover	84
Control circuit terminal layout	85
XAI: Reference voltages and analog inputs	86
XAO: Analog outputs	86
XD2D: Drive-to-drive link	86
RO1, RO2, RO3: Relay outputs	87
XD24: Digital interlock	87
XDIO: Digital inputs / outputs	88
XDI: Digital inputs	88
XENC: Encoder	88
XTAC: Analog tacho	88
XSMC: Mains contactor	89
XSTO: Safe torque off	89
X205 Memory unit connection	89
Replacing the memory unit	90
Additional terminals	90
Ground isolation diagram	91
Jumpers and switches	92
DDCS Interface configuration	93
Ch0 DriveBus or module bus connection to Advant Controller (star)	93
DDCS branching unit NDBU-95	94
DCSLink board SDCS-DSL-H1x (H1 ... H8)	95
Daisy chain DPI-H01 kit (H1 ... H8)	96
Power Interface board SDCS-PIN-H01 (H1 ... H5)	99
Layout SDCS-PIN-H01	99
Technical data	100
Power supply board SDCS-POW-H01 (H6 ... H8)	101
Field circuit interfaces SDCS-BAB-F01 and SDCS-BAB-F02 (H1 ... H4)	102
Ratings OnBoard field exciter	102

Cables	102
Measuring board SDCS-PIN-H51 (H6 ... H8)	107
Firing pulse transformer board SDCS-PIN-H41 (H6 ... H8)	109
Optical power link board SDCS-OPL-H01 (H7, H8)	110
Following connectors are available	110
XSMC (X96): Mains contactor	110
Location of the SDCS-OPL-H01	111
Connection between firing and control board for H6 ... H8	112
Galvanic isolation - T90, A92, F11, F90	115
DC-DC transducer A92 (1)	117
Transformer T90	118

Dimensions and weights

Size H1	119
Size H2	120
Size H3	121
Size H4	122
Size H5	123
Size H6	124
Size H7	
(+P906)	125
Size H8 lefthand (+P906)	126
Size H8 righthand (+P906)	127
Branch fuses installed inside converter sizes H5 ... H8	128

Accessories

DCF803-0016, FEX-425-Int and DCF803-0035	130
Electrical data	131
Control unit	131
Power part	131
DCSLink communication	132
RS232-Port	133
Diagnostics	133
DCF803-0016 and DCF803-0035 configuration (H1 ... H8)	134
Dimensions	135
FEX-425-Int configuration (H5)	136
FEX-425-Int configuration (H6)	137
DCF803-0050, DCF804-0050, DCF803-0060 and DCF804-0060	138
Electrical data	139
Control unit	140
Power part	140
DCSLink communication	141
RS232-Port	141
Diagnostics	142
DCF803-0050 / 0060 and DCF804-0050 / 0060 configuration (e.g. 2 motors)	143
Dimensions	146
DCF505 / DCF506 Overvoltage Protection	147
Fuses and fuse holders IEC	150

Semiconductor fuses and fuse holders for AC and DC power lines	150
Line reactors IEC	151
Line reactors type ND01 ... ND17 (uk = 1 %)	151
Line reactors type ND401 ... ND413 (uk = 4 %)	155
Autotransformer (T3)	157
Line reactor (L3)	158
Auxiliary transformer (T2) for converter electronics and fans	159
Supply transformer (T8) for cooling fans	160
Dimensions	160
Optical cables	161
Other cables	162
Recommended connectors	162

Safety instructions

What this chapter contains

This chapter contains the safety instructions which you must follow when installing, operating and servicing the drive. If ignored, physical injury or death may follow, or damage may occur to the drive, the motor or driven equipment. Read the safety instructions before you work on the unit.

To which products this chapter applies

The information is valid for the whole range of the product DCS880, the converter modules DCS880-S0x size H1 ... H8, field exciter units DCF80x, etc. like the Rebuild Kit DCS880-R00.

Use of warnings and notes

There are two types of safety instructions throughout this manual: warnings and notes. Warnings caution you about conditions which can result in serious injury or death and/or damage to the equipment and advice on how to avoid the danger. Notes draw attention to a particular condition or fact, or give information on a subject. The warning symbols are used as follows:



Dangerous voltage warning warns of high voltage which can cause physical injury and/or damage to the equipment.



General danger warning warns about conditions, other than those caused by electricity, which can result in physical injury or death and/or damage to the equipment.



Electrostatic sensitive discharge warning warns of electrostatic discharge which can damage the equipment.

Installation and maintenance work

These warnings are intended for all who work on the drive, motor cable or motor. Ignoring the instructions can cause physical injury or death and/or damage to the equipment.



WARNING

- **Only qualified electricians are allowed to install and maintain the drive!**
- Never work on the drive, motor cable or motor when main power is applied.
- Always ensure by measuring with a multimeter (impedance at least 1 MOhm) that:
 1. Voltage between drive input phases U1, V1 and W1 and the frame is close to 0 V.
 2. Voltage between terminals C+ and D- and the frame is close to 0 V.
- Do not work on the control cables when power is applied to the drive or to the external control circuits. Externally supplied control circuits may cause dangerous voltages inside the drive even when the main power on the drive is switched off.
- Do not make any insulation resistance or voltage withstand tests on the drive or drive modules.
- Isolate the motor cables from the drive when testing the insulation resistance or voltage withstand of the cables or the motor.
- When reconnecting the motor cable, always check that the C+ and D- cables are connected with the proper terminal.

Notes:

- The motor cable terminals on the drive are at a dangerously high voltage when the main power is on, regardless of whether the motor is running or not.
- Depending on the external wiring, dangerous voltages (115 V, 220 V or 230 V) may be present on the relay outputs of the drive system (e.g. XRO1 ... XRO3).
- DCS880 with enclosure extension: Before working on the drive, isolate the whole drive from the supply.

Grounding



These instructions are intended for all who are responsible for the grounding of the drive. Incorrect grounding can cause physical injury, death and/or equipment malfunction and increase electromagnetic interference.



WARNING

- Ground the drive, motor and adjoining equipment to ensure personnel safety in all circumstances, and to reduce electromagnetic emission and pick-up.
- Make sure that grounding conductors are adequately sized and marked as required by safety regulations.
- In a multiple-drive installation, connect each drive separately to protective earth (PE ).
- Minimize EMC emission and make a 360° high frequency grounding (e.g. conductive sleeves) of screened cable entries at the cabinet lead-through plate.
- Do not install a drive equipped with an EMC filter to an ungrounded power system or a high resistance-grounded (> 30 Ohms) power system.

Notes:



- Power cable shields are suitable as equipment grounding conductors only when adequately sized to meet safety regulations.
- As the normal leakage current of the drive is higher than 3.5 mA_{AC} or 10 mA_{DC}, a fixed protective earth connection is required.
- This product can cause a DC current in the protective earthing conductor. Where a residual current-operated protective (RCD) or monitoring (RCM) device is used for protection in case of direct or indirect contact, only an RCD or RCM of Type B is allowed on the supply side of this product.

Printed circuit boards and fiber optic cables

These instructions are intended for all who handle the circuit boards and fiber optic cables. Ignoring the following instructions can cause damage to the equipment.



WARNING

- The printed circuit boards contain components sensitive to electrostatic discharge. Wear a grounding wrist band when handling the boards. Do not touch the boards unnecessarily.
- Use grounding strip:



ABB order no.: 3ADV050035P0001



WARNING

- Handle the fiber optic cables with care.
- When unplugging optic cables, always grab the connector, not the cable itself.
- Do not touch the ends of the fibers with bare hands as the fiber is extremely sensitive to dirt.
- The minimum allowed bend radius is 35 mm (1.38 in.).

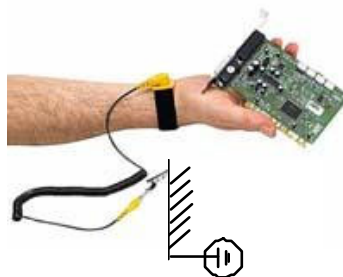
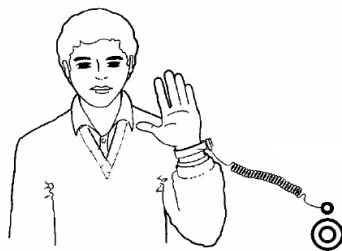
Mechanical installation

These notes are intended for all who install the drive. Handle the unit carefully to avoid damage and injury.

WARNING





- DCS880 sizes H4 ... H8:
 - The drive is heavy. Lift the drive by lifting lugs only.
 - The drive's center of gravity is high. Do not tilt the unit. The unit will overturn from a tilt of about 6 degrees. An overturning drive can cause physical injury.
 - Do not lift the unit by the front cover.
 - Place units H4 ... H6 only on their back.
- Make sure that dust from drilling does not enter the drive when installing. Electrically conductive dust inside the unit may cause damage or lead to malfunction.
- Ensure sufficient cooling.
- Do not fasten the drive by riveting or welding.

Operation

These warnings are intended for all who plan the operation of the drive or operate the drive. Ignoring the instructions can cause physical injury or death and/or damage to the equipment.



WARNING

- Before adjusting the drive and putting it into service, make sure that the motor and all driven equipment are suitable for operation throughout the speed range provided by the drive. The drive can be adjusted to operate the motor at speeds above and below the base speed.
- Do not control the motor with the disconnecting device (disconnecting mains); instead, use the control panel keys  and , or commands via the I/O board of the drive.
- Mains connection:
You can use a disconnect switch (with fuses) to disconnect the electrical components of the drive from the mains for installation and maintenance work. The type of disconnect switch used must be as per EN 60947-3, Class B, so as to comply with EU regulations, or a circuit-breaker type which switches off the load circuit by means of an auxiliary contact causing the breaker's main contacts to open. The mains disconnect must be locked in its "OPEN" position during any installation and maintenance work.
- EMERGENCY STOP buttons must be installed at each control desk and at all other control panels requiring an emergency stop function. Pressing the STOP button on the control panel of the drive will neither cause an emergency stop of the motor, nor will the drive be disconnected from any dangerous potential.
- To avoid unintentional operating states, or to shut the unit down in case of any imminent danger according to the standards in the safety instructions it is not sufficient to merely shut down the drive via signals "RUN", "drive OFF" or "Emergency Stop" respectively "control panel" or "PC tool".
- Intended use:
The operating instructions cannot take into consideration every possible case of configuration, operation or maintenance. Thus, they mainly give such advice only, which is required by qualified personnel for normal operation of the machines and devices in industrial installations.
If in special cases the electrical machines and devices are intended for use in non-industrial installations - which may require stricter safety regulations (e.g. protection against contact by children or similar) - these additional safety measures for the installation must be provided by the customer during assembly.

Note:

- When the control location is not set to Local (Local not shown in the status row of the display), the stop key on the control panel will not stop the drive. To stop the drive using the control panel, press the Loc/Rem key and then the stop key .

The DCS880

Chapter overview

This chapter describes briefly the operating principle and construction of the converter modules in short.

The DCS880 converter modules

The DCS880-S size H1 ... H8 are intended for controlling DC motors.



Size H1 ... H5
20 ... 1190 A



Size H6
900 ... 2000 A



Size H7
1900 ... 3000 A



Size H8
2050 ... 5200 A

Type code

The type code contains information on the specification and configuration of the drive. The first digits from left show the basic configuration (e.g. DCS880-S01-2000). The optional selections are given thereafter on the name plate by plus code. The main selections are described below. Not all selections are available for all types.

The drive's basic type code: DCS880-aab-cccc-ddef + plus code			
Product family	DCS880		
Product type:	aa	= S0 = R0 = E0 = A0	Standard converter module Rebuild kit Panel solution Enclosed converter
Bridge type:	b	= 1 = 2	Single bridge (2-Q) 2 anti-parallel bridges (4-Q)
Module type:	cccc	=	Rated DC current (IP00)
Rated AC voltage:	dd	= 04 = 05 = 06 = 07 = 08 = 10 = 12	100 V _{AC} ... 415 V _{AC} 100 V _{AC} ... 500 V _{AC} (IEC), 525 V _{AC} (UL) 270 V _{AC} ... 600 V _{AC} 315 V _{AC} ... 690 V _{AC} 360 V _{AC} ... 800 V _{AC} 450 V _{AC} ... 990 V _{AC} 540 V _{AC} ... 1190 V _{AC}
Power connection:	e	= X = L = R	Standard H1 ... H7 Left side H8 Right side H8
Revision code:	f	= 0	1 st generation
Field exciter configuration:	+0S163 +S164		H1 ... H4 without OnBoard field exciter H5 and H6 with internal field exciter, supply external (H5 and H6: 25 A, Rebuild kit: 16 A / 25 A)
Fan voltage:	Standard		Size H4 Fan voltage: 230 V / 1-ph
Application programming:	+S551		Memory unit including drive application programming license
SDCS-DSL-H10:	+S521		1 DCSELink channel, 0 channels optical power link SDCS-DSL-H10 (H1 ... H4)
Current measurement:	+S175		SDCS-CMA-2 (H6 ... H8)
Voltage measurement:	+S185		SDCS-PIN-H51 configured for 20 V _{AC} ... 100 V _{AC} (H6 ... H8)
Control panel:	+0J404 +J428 +J429		Without control panel daisy-chain option DPI-H01 kit Bluetooth control panel ACS-AP-W

The technical data and specifications are valid as of going to press. ABB reserves the right to make subsequent alterations.

Plus codes

Option	Option code	Description
ACS-AP-I	standard	built-in
no ACS-AP-I	0J404	No Control Panel
ACS-AP-W	+J429	Bluetooth panel
DPI-H01	+J428	daisy-chain option
FDNA-01	+K451	Fieldbus DeviceNet
FPBA-01	+K454	Fieldbus PROFIBUS
FCAN-01	+K457	Fieldbus CANOpen
FSCA-01	+K458	Fieldbus Modbus
FCNA-01	+K462	Fieldbus ControlNet
FECA-01	+K469	Fieldbus EtherCat
FEPL-02	+K470	Fieldbus Ethernet POWERLINK
FENA-11	+K473	Ethernet/IP, Modbus/TCP, Profinet
FENA-21	+K475	Ethernet/IP, Modbus/TCP, Profinet
FIO-11	+L500	Analog I/O Extension (3 AI, 1 AO, 2 DIO)
FIO-01	+L501	Digital I/O Extension (4 DIO, 2 RO)
FAIO-01	+L525	Analog I/O Extension (2 AI, 2 AO)
FDIO-01	+L526	Digital I/O Extension (3 DI, 2 RO)
FPTC-01	+L536	Thermistor protection module
FEN-01	+L517	TTL Encoder interface
FEN-21	+L516	Resolver Interface
FEN-31	+L502	HTL Encoder Interface
FDCO-01	+L503	DDCS communication 10/10 MBd
FDCO-02	+L508	DDCS communication 5/10 MBd
Application programming	+S551	Memory unit including drive application programming license
no OnBoard field exciter	0S163	Excludes OnBoard field exciter (H1 ... H4)
SDCS-DSL-H10	+S521	1 DCSLink channel, 0 channels optical power link
FSO-21	+Q972	Functional Safety Option
FSE-31	+L521	Functional Safety Encoder

Main circuit and control

Armature converter DCS880 H1 ... H4

400 V and 500 V (IEC) / 525 V (UL) units with OnBoard field exciter. 600 V units are always without OnBoard field exciter.

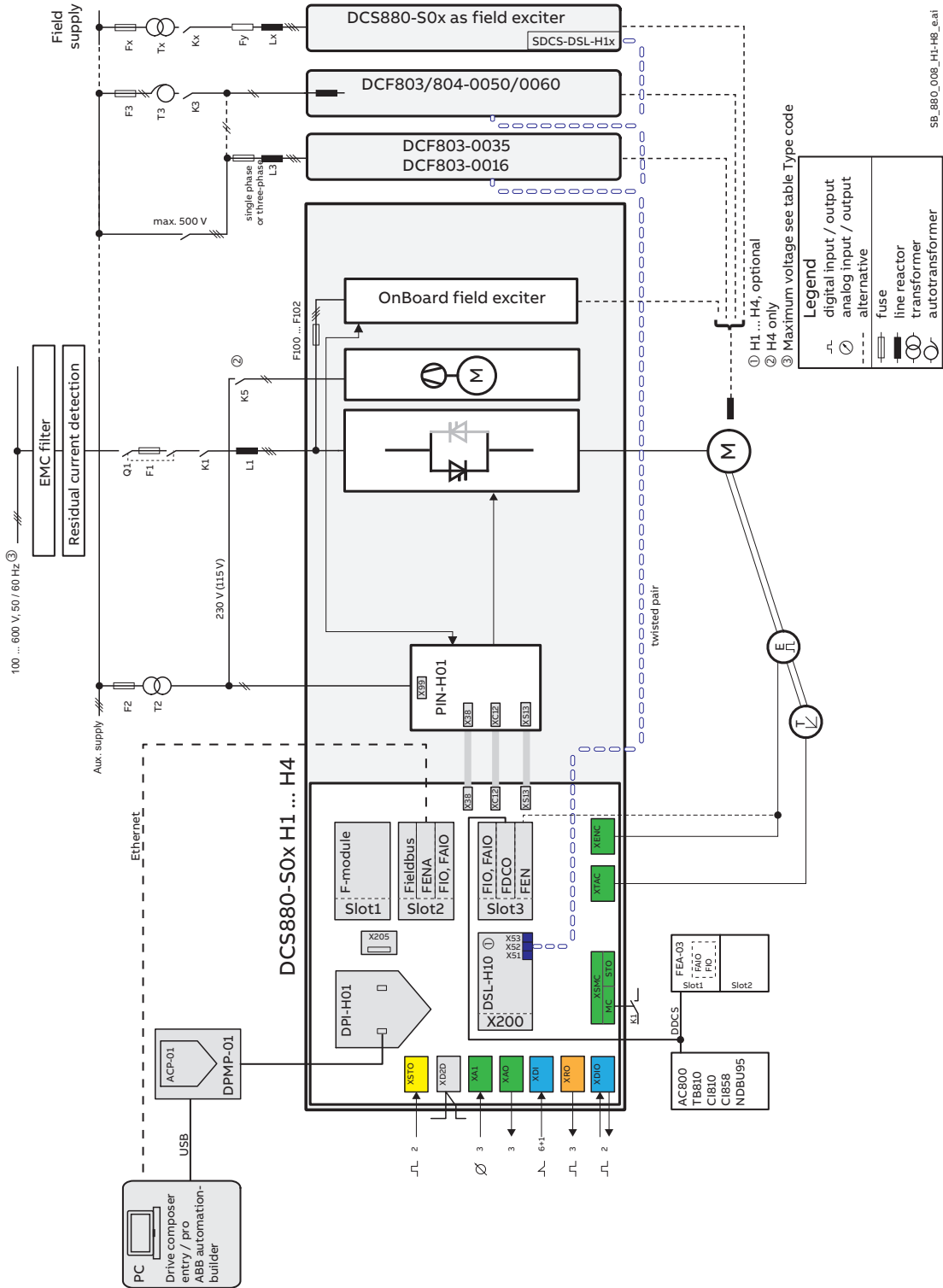

Armature converter DCS880 H5

H5 units with optional internal field exciter.

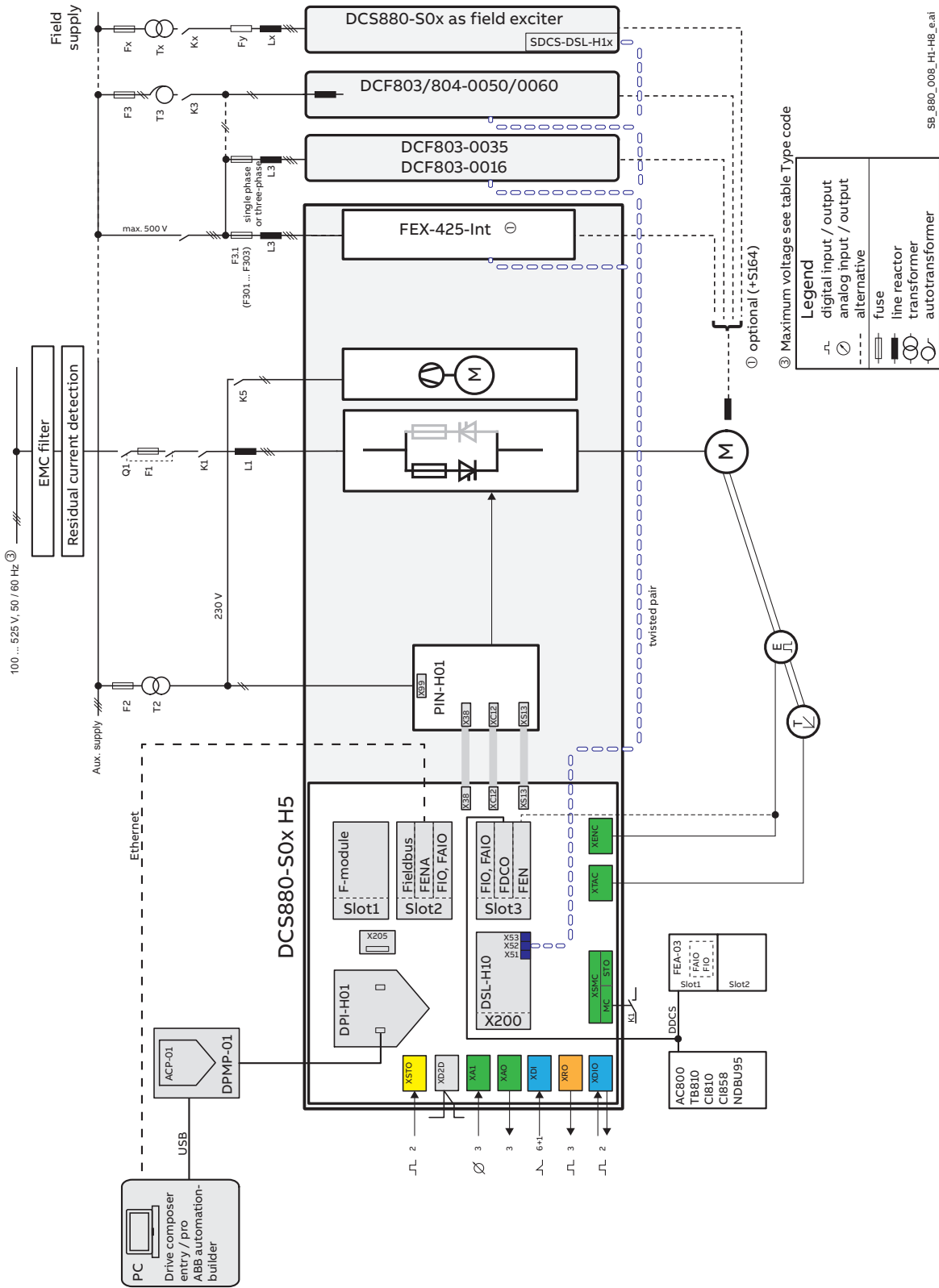

SB_880_008_H1-H8_s.at

③ Maximum voltage see table Type code

① optional (+S164)

Armature converter DCS880 H6

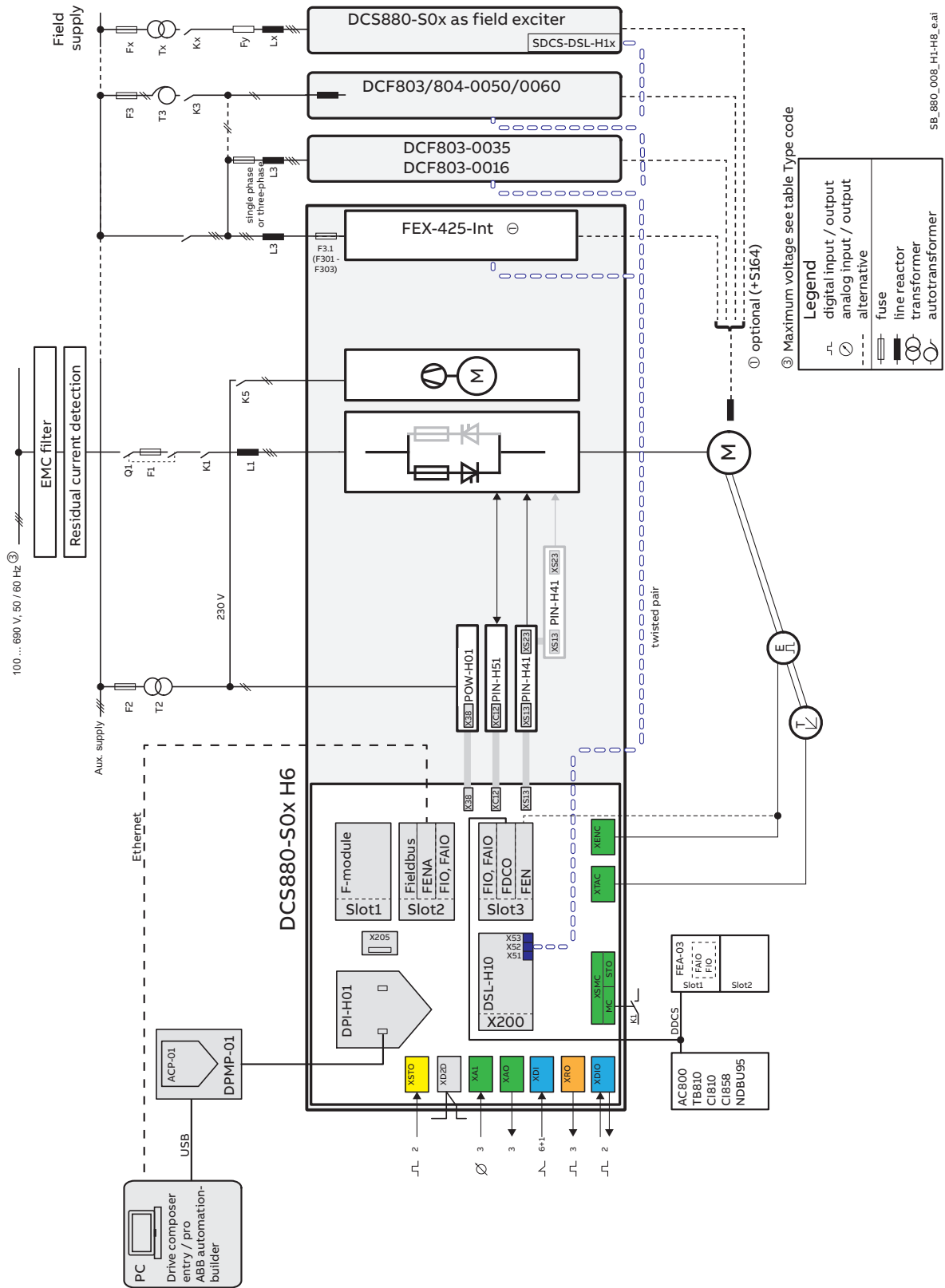

Armature converter DCS880 H7 and H8

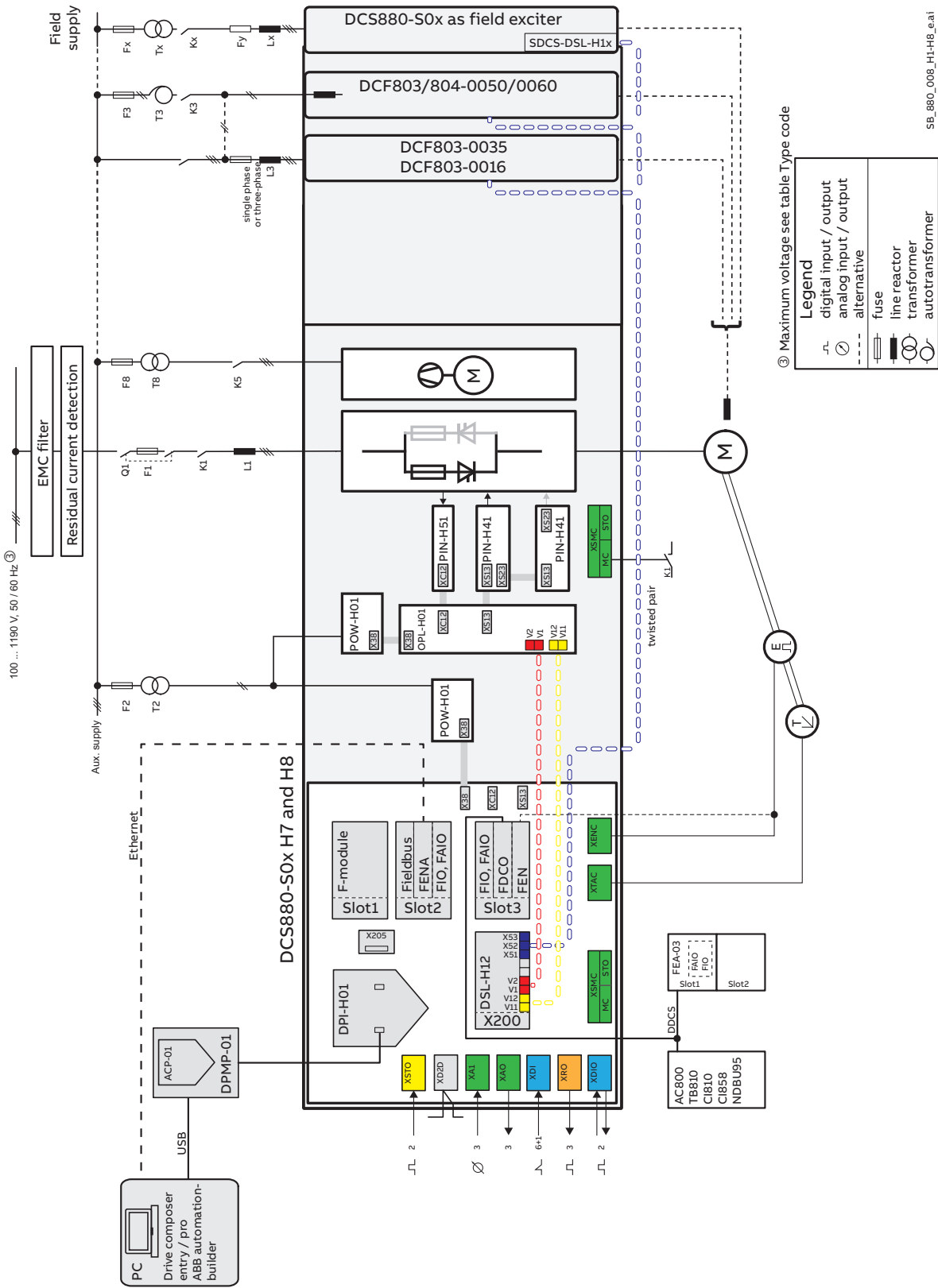

Mechanical installation

Chapter overview

This chapter describes the mechanical installation of the DCS880.

Safety



WARNING

- DCS800 sizes H4 ... H8:
 - The drive is heavy. Lift the drive by lifting lugs only.
 - The drive's center of gravity is high. Do not tilt the unit. The unit will overturn from a tilt of about 6 degrees. An overturning drive can cause physical injury.
 - Do not lift the unit by the front cover.
 - Place units H4 ... H6 only on their back.

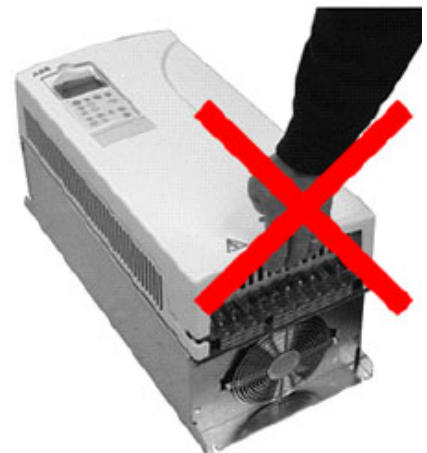
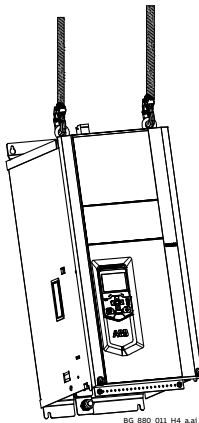

Examining the installation site

The drive must be installed in an upright position with the cooling section against a wall.

Make sure that the installation site agrees with these requirements:

- The installation site has sufficient ventilation to prevent overheating of the drive. See chapter [Current ratings](#).
- The operation conditions of the drive agree with the specifications in chapter [Environmental Conditions](#).
- The wall is vertical, not flammable and strong enough to hold the weight of the drive.
- The material below the installation is not flammable.
- There is enough free space above, beside and below the drive for cooling air flow, service and maintenance. There is enough free space in front of the drive for operation, service and maintenance. See chapter [Dimensions and weights](#).

Necessary tools

- Drill and drill bits.
- Screwdriver and/or wrench with bits. Some drive covers have torx screws.

Moving the drive

Move the transport package by pallet truck to the installation site.

Unpacking and examining the delivery (H1 ... H3)

This illustration shows the layout of the transport package. Examine that all items are present.

Item	Description
1	Drive with factory installed options.
2	Cardboard box.
3	Shock damper.
4	Shock dampers.
5	Tray.
6	Package containing documentation, plugs, mounting material, etc.

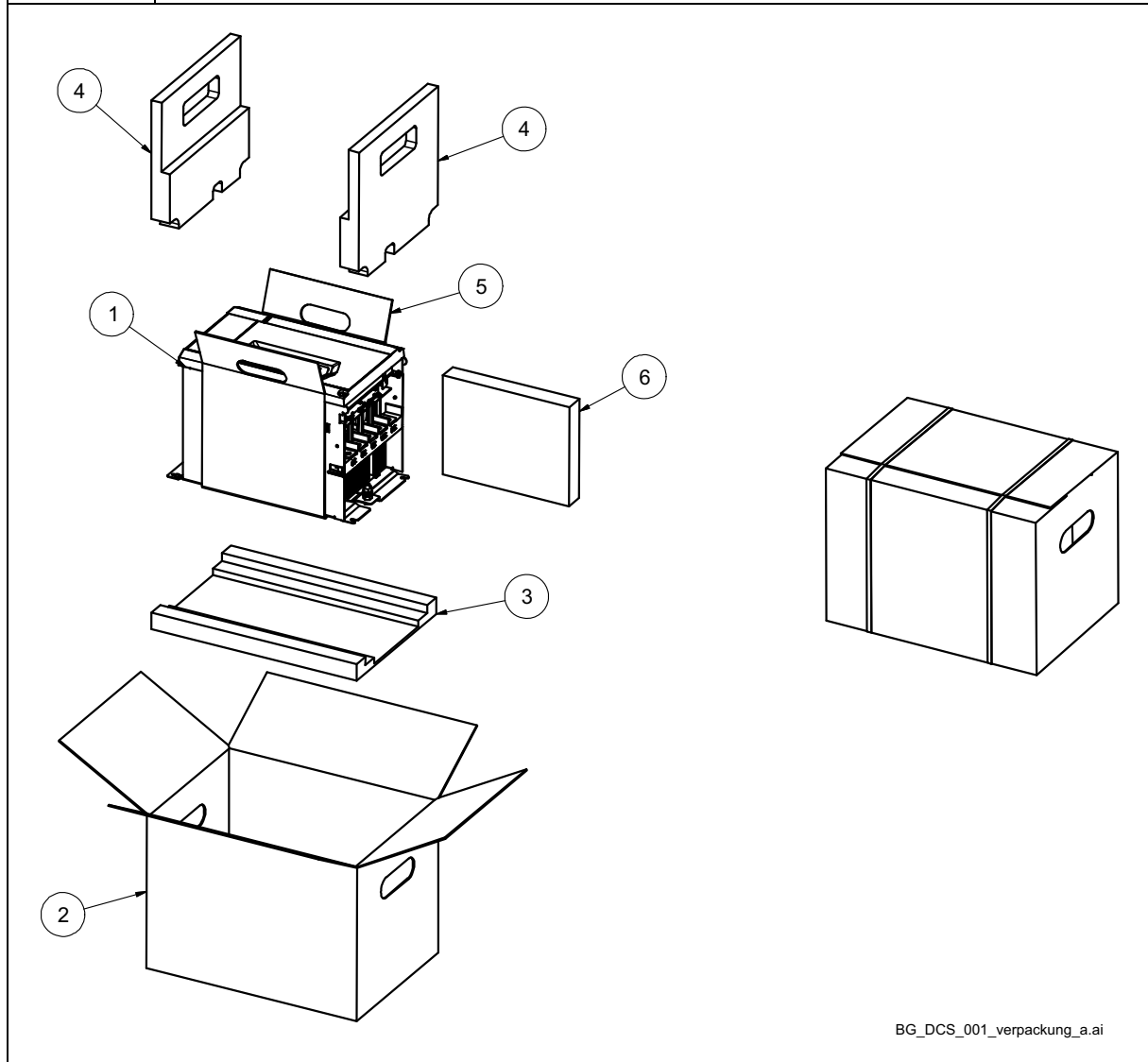

BG_DCS_001_verpackung_a.ai

Unpacking and examining the delivery (H4)

This illustration shows the layout of the transport package. Examine that all items are present.

Item	Description
1	Drive with factory installed options.
2	Cardboard box.
3	Shock damper.
4	Shock dampers.
5	Shock damper.
6	Package containing documentation, plugs, mounting material, etc.

BG_DCS_001_verpackung_a.ai

Unpacking and examining the delivery (H5)

This illustration shows the layout of the transport package. Examine that all items are present.

Item	Description
1	Drive with factory installed options.
1.a	Converter fan, remove before installation.
1.b	Lifting lugs bracket.
1.c	Lifting lugs bracket, attach before installation.
2	Cardboard box.
3	Shock dampers.
4	Package containing documentation, plugs, mounting material, etc.

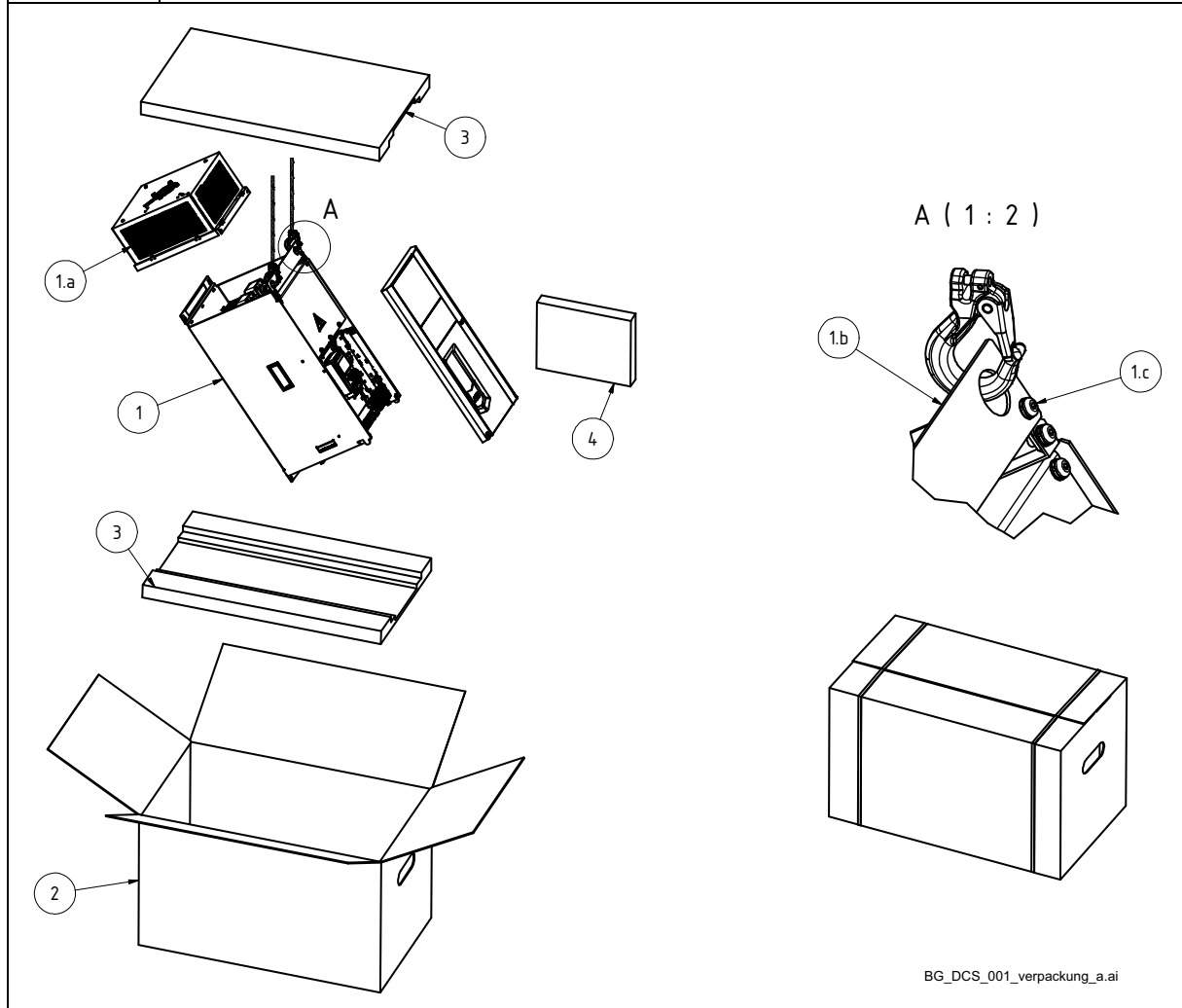

Unpacking and examining the delivery (H6)

This illustration shows the layout of the transport package. Examine that all items are present.

Item	Description
1	Drive with factory installed options.
2	Cardboard box.
3	Shock damper.
4	Lower and upper cardboard box cover.
5	Shock dampers.
6	Package containing documentation, plugs, mounting material, etc.

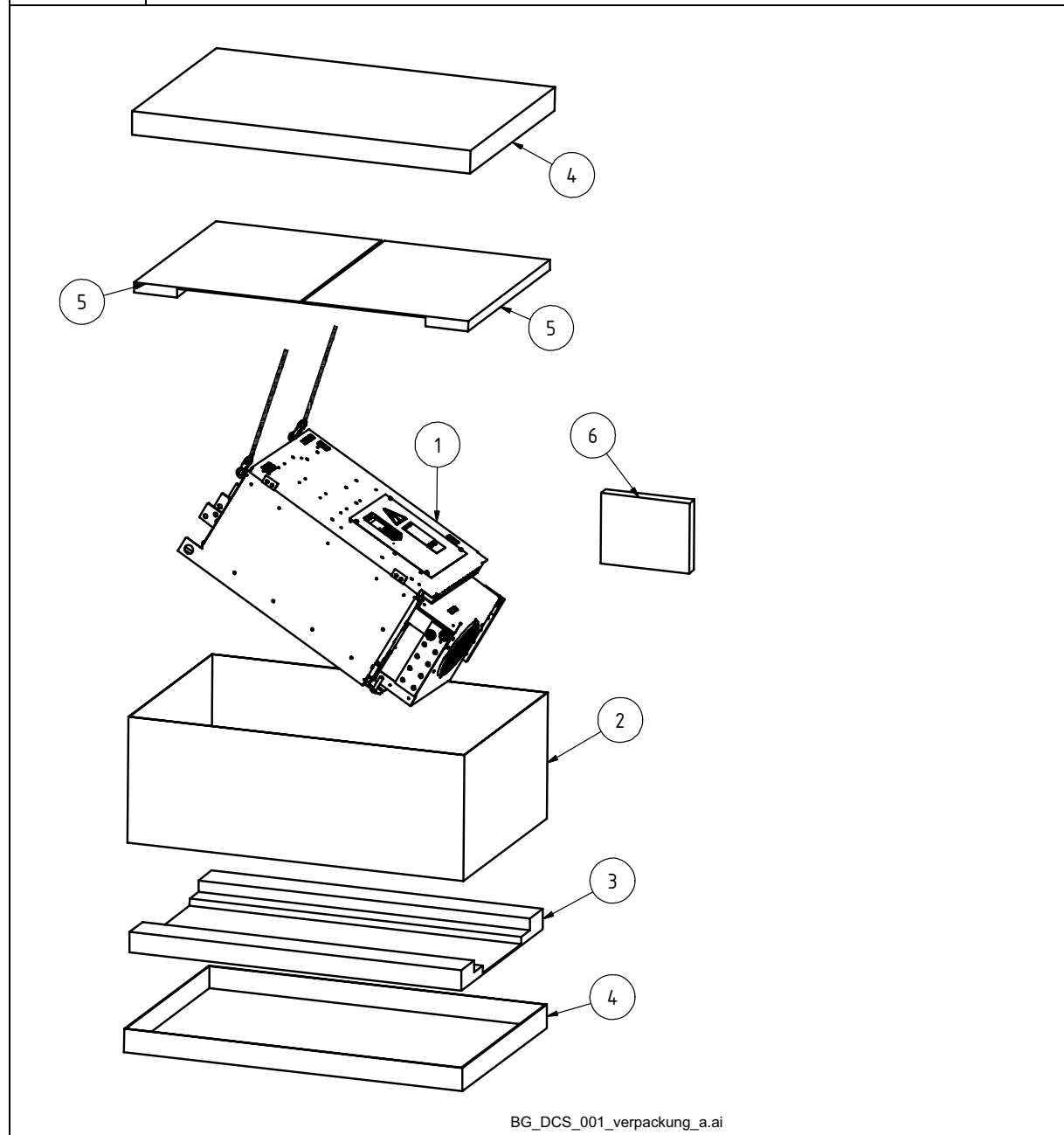

Unpacking and examining the delivery (H7, H8)

This illustration shows the layout of the transport package. Examine that all items are present.

Item	Description
1	Drive with factory installed options.
2	Cardboard box.
3	Lower cardboard box cover.
4	Brackets to fasten the drive, remove before installation.
5	Shock damper.
6	Package containing documentation, plugs, mounting material, etc.

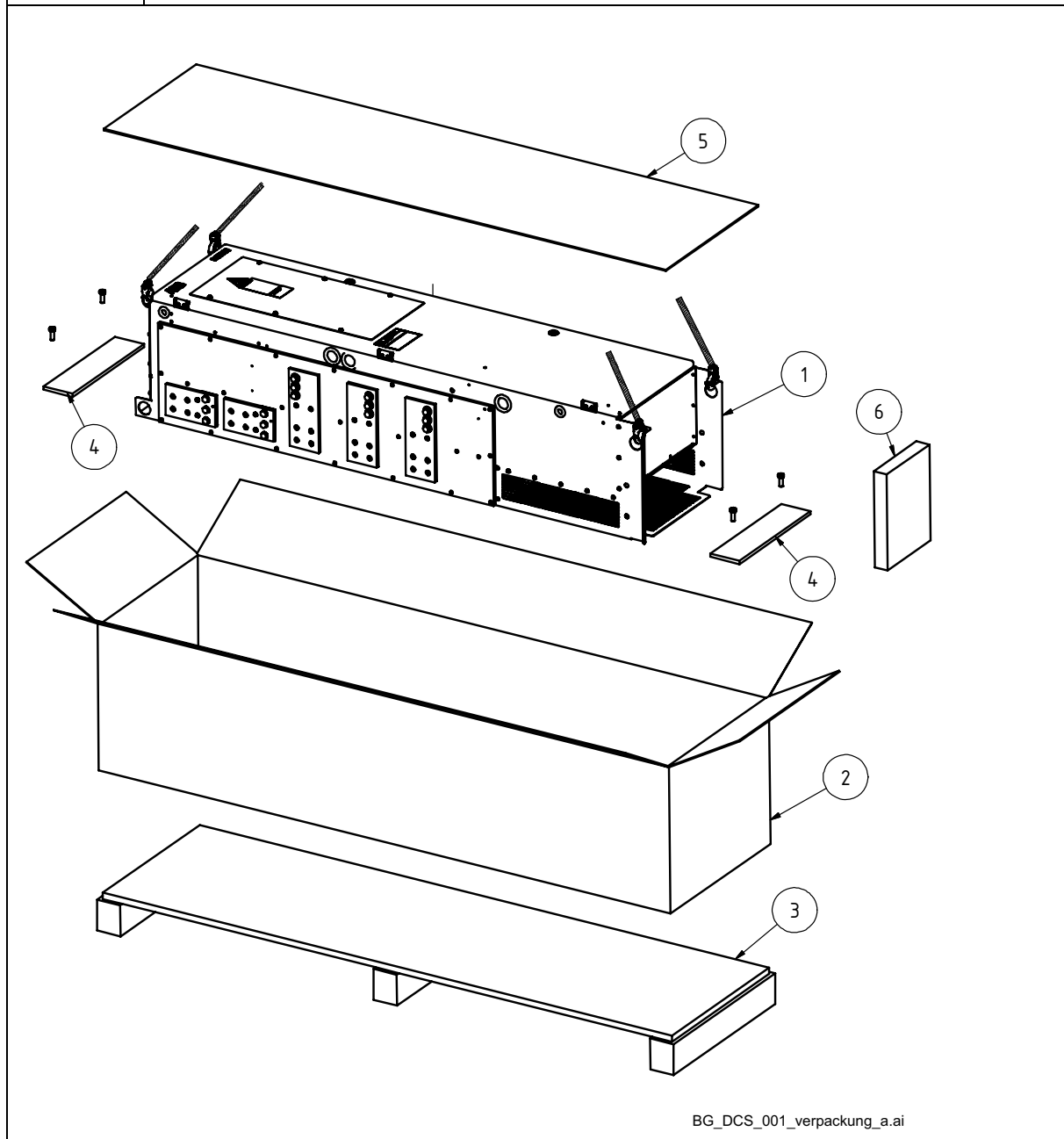

Delivery check

Check that there are no signs of damage. Before attempting installation and operation, check the information on the nameplate of the converter module to verify that the unit is of the correct type. The label includes an IEC rating, cULus, C-tick (N713) and CE markings, a type code and a serial number, which allow individual identification of each unit. The remaining digits complete the serial number so that there are no two units with the same serial number.

See an example nameplate below.

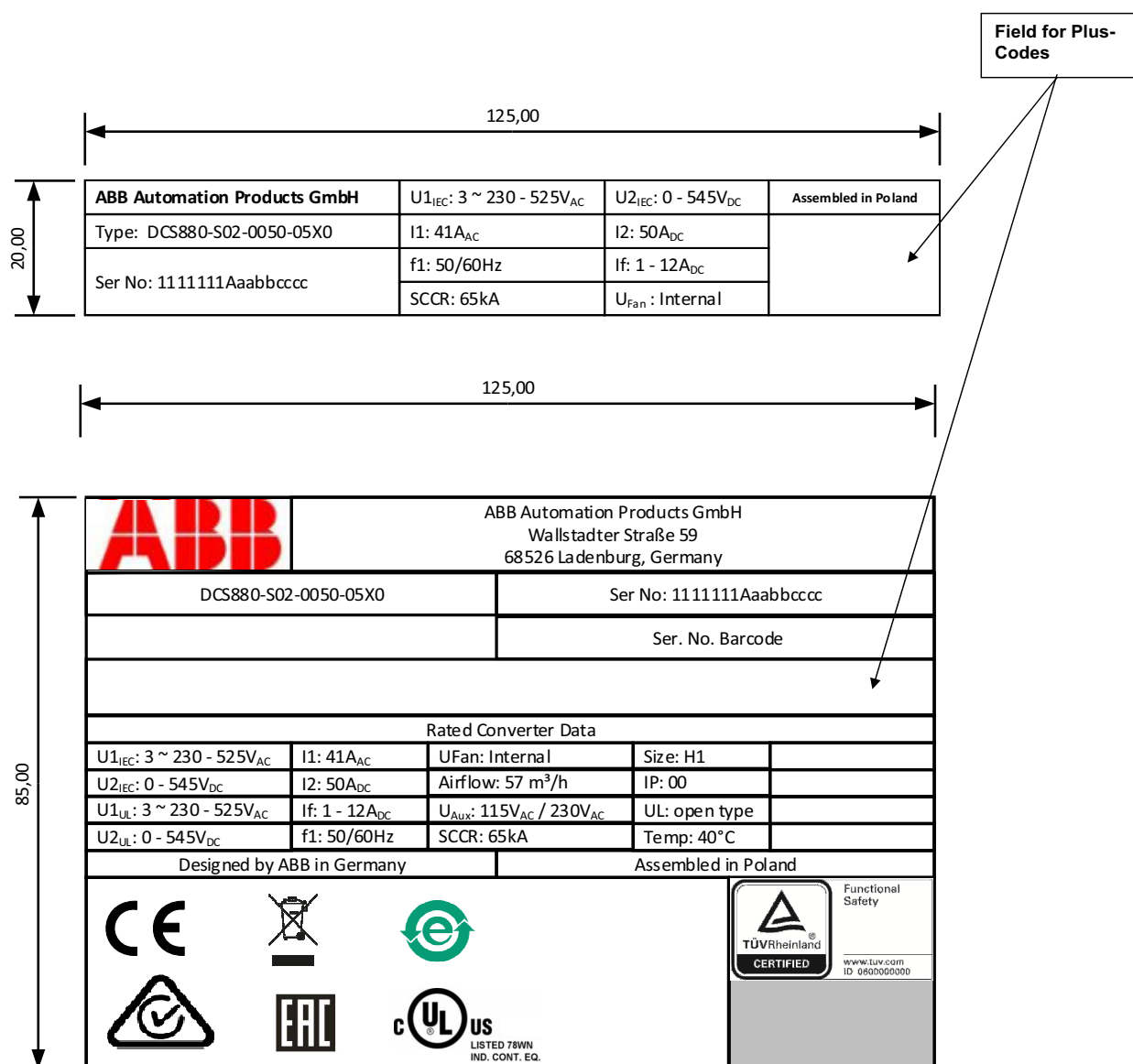

Ser. No.	0025421A17294264 1729 = Production year 2017 and week 29.
U _{1IEC}	Rated input voltage according to IEC.
U _{2IEC}	Rated output voltage according to IEC.
U _{1UL}	Rated input voltage according to UL.
U _{2UL}	Rated output voltage according to UL.
I ₁	Rated input current.
I ₂	Rated output current.
I _f	Rated internal field exciter current.
f ₁	Rated frequency of mains voltage.
U _{Fan}	Rated fan voltage.
Airflow	Rated cooling air flow.
U _{Aux}	Rated auxiliary voltage.
Size	Unit size.
SCCR	Short circuit current ratio.
IP: 00	Protection class according to ISO20653.
UL: open type	Protection class according to UL.
Temp	Max. permissible cooling air temperature.

Installing the drive (H1 ... H3)

This section tells you how to install the drive on wall without vibration dampers. The degree of protection is IEC: IP00 and UL: open type.

1. See the dimensions in chapter [Dimensions and weights](#). Mark the locations for the four mounting holes.
2. Drill the mounting holes.
3. Insert wall plugs into the holes and start to screw bolts into the plugs. Drive the bolts deep enough into the wall to make them carry the weight of the drive.
4. Position the drive onto the bolts on the wall.
5. Tighten the bolts securely in the wall.

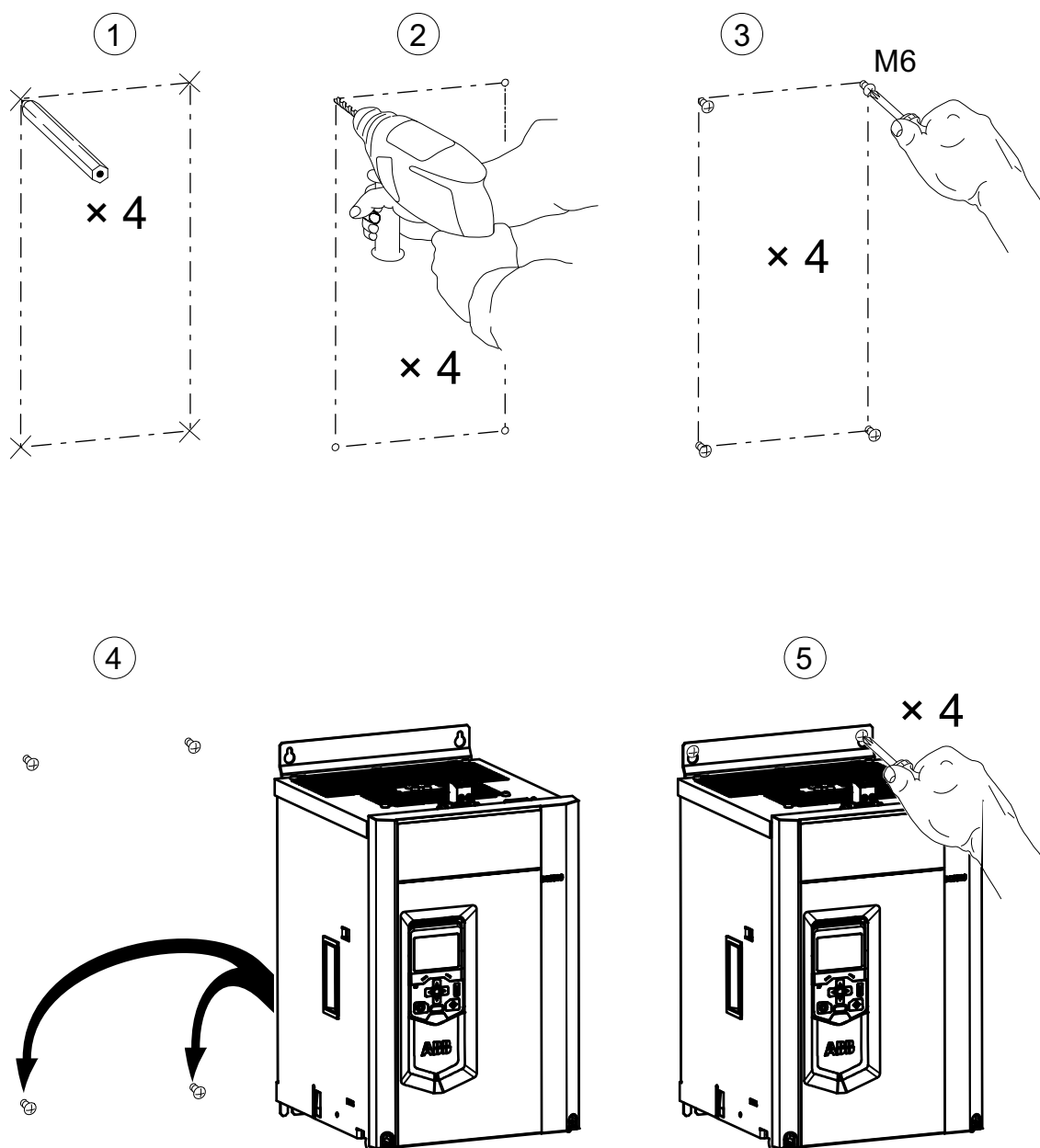

BG_880_013_H3-Bef_a.ai

Installing the drive (H4, H5)

This section tells you how to install the drive on wall without vibration dampers. The degree of protection is IEC: IP00 and UL: open type.

1. See the dimensions in chapter [Dimensions and weights](#). Mark the locations for the four mounting holes.
2. Drill the mounting holes.
3. Insert wall plugs into the holes and start to screw bolts into the plugs. Drive the bolts deep enough into the wall to make them carry the weight of the drive.
4. Position the drive onto the bolts on the wall.
5. Tighten the bolts securely in the wall.
6. For H5 re-install the converter fan.

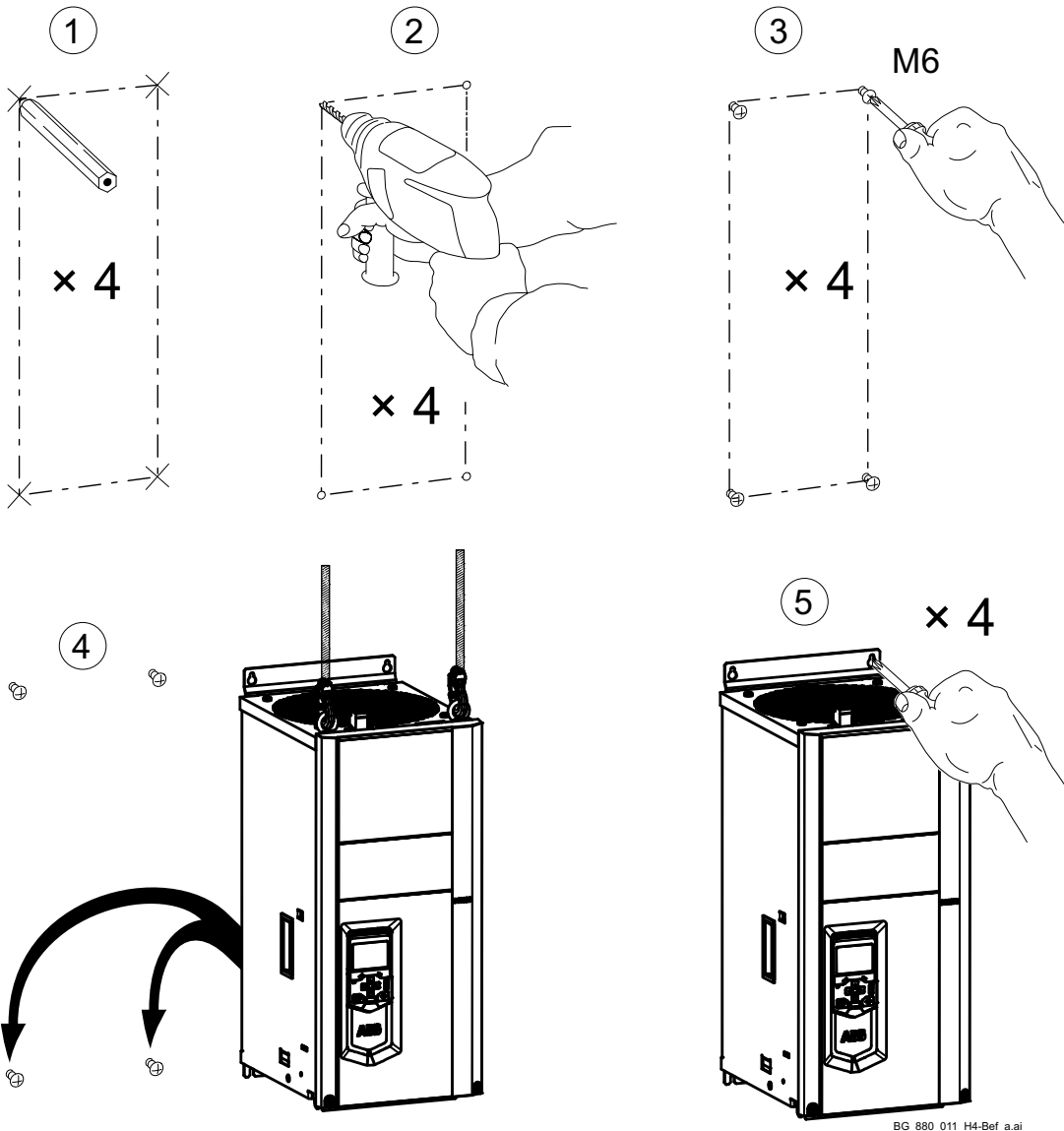

Installing the drive (H6 ... H8)

Drives of sizes H6 ... H8 are for cabinet mounting only.

Cabinet installation

The required distance between parallel units is five millimetres (0.2 in.) in installations without the front cover. The cooling air entering the unit must not exceed +40 °C (+104 °F).

Preventing cooling air recirculation

Prevent air recirculation inside and outside the cabinet.

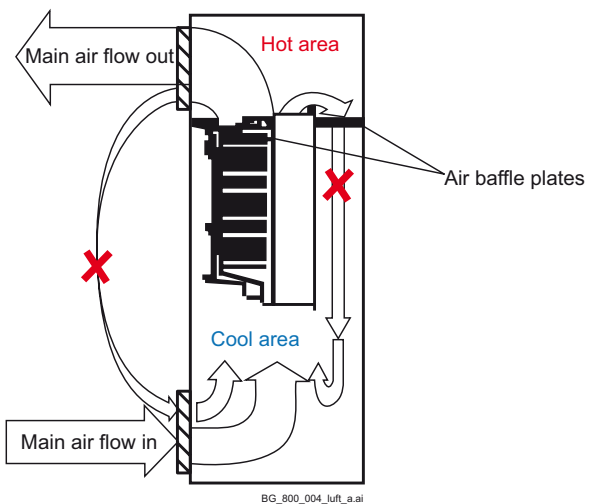

Unit above another

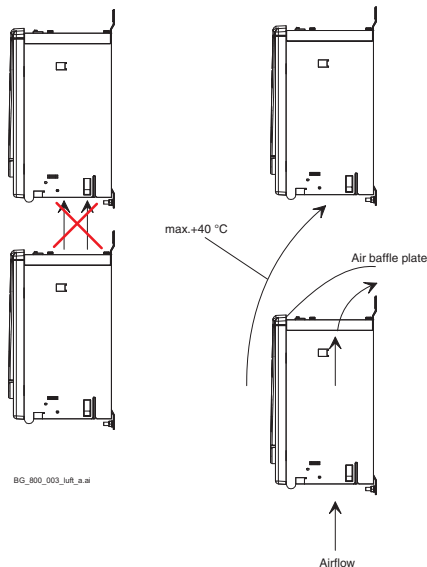

Lead the exhaust cooling air away from the unit above.
Distances see chapter [Dimensions and weights](#).

Recommended air entry / exit sizes in case of filters (IP22).

Size	Nominal converter current [A]	Air entry size [m ²]	Air exit size [m ²]
H1	20 ... 100	0.22	0.11
H2	135 ... 300		
H3	290 ... 350		
H3	405 ... 520	0.31	0.15
H4	590 ... 1000	0.22	0.11
H5	1190		
H6	900 ... 2000	0.44	0.31
H7	1900 ... 3000		
H8	2050 ... 5200	0.52	

Terminal options for converter modules size H1 ... H4

There are different options to protect and connect the terminals.

Connection of H4 converter module DC terminals

In some cases it is beneficial to use lug bars for easy DC cable connection.

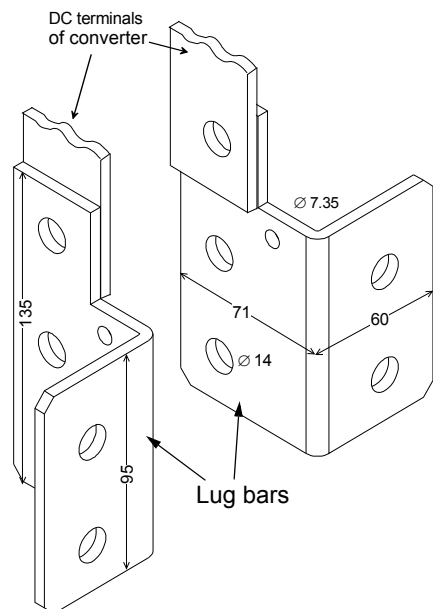

Id No.	Remark
3ADV280706P0001	right
3ADV280706P0002	left

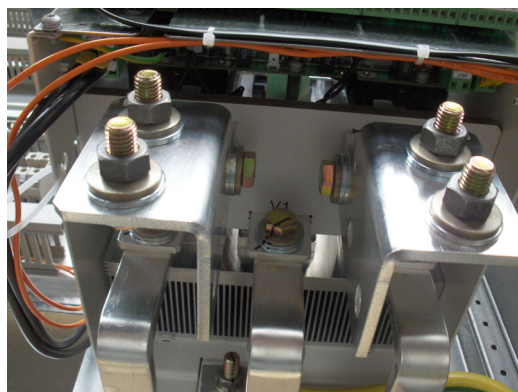

Bottom view

Terminal cover according to VBG 4 regulations (H1 ... H4 only)

For converter modules size H1 ... H4 shrouds for protection against contact are provided.

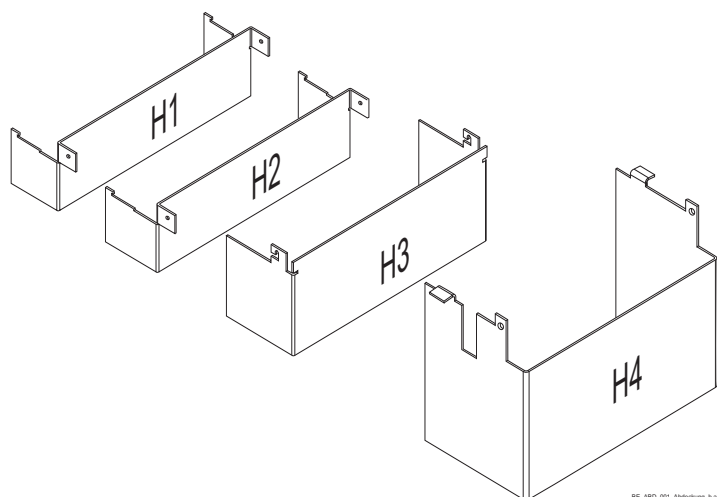

Id No.	Remark
3ADT631236P0001	H1
3ADT631237P0001	H2
3ADT631238P0001	H3
3ADT631239P0001	H4

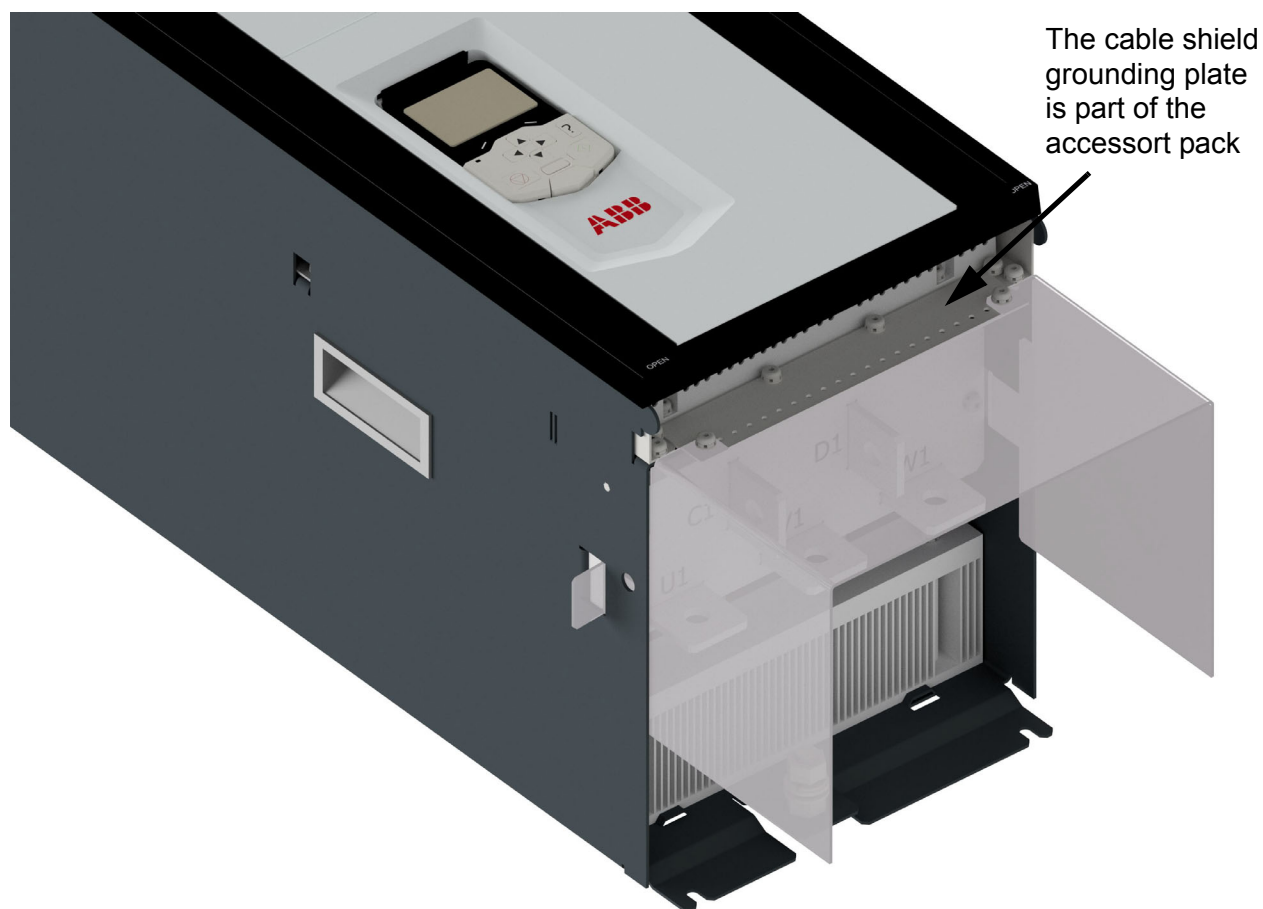

Example for DC main terminal cover for H4 converter modules.

Mounting the converter module H5 inside an enclosure

Cooling air inlet

The cooling fan blows the air out of the front, right and left side of the converter module. View from:

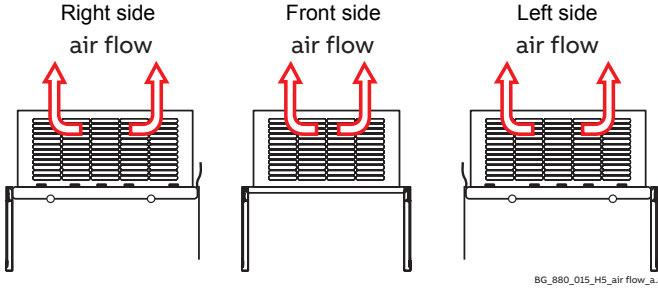

Free space around the converter module

In mm:

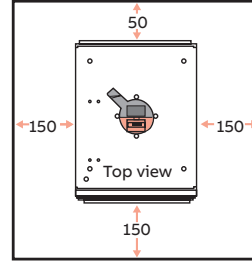

Cooling air outlet

To avoid circulating air inside the enclosure make sure the exhaust air leaves the enclosure.

Mounting the converter module:

1. Remove the control panel and design cover:
2. Remove screws (T20) and pull out the fan box:



3. Now all mounting holes are accessible:

Detail top:

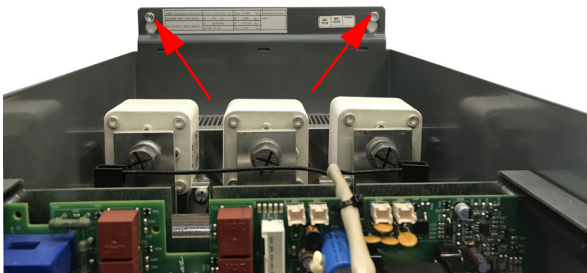

Detail bottom:

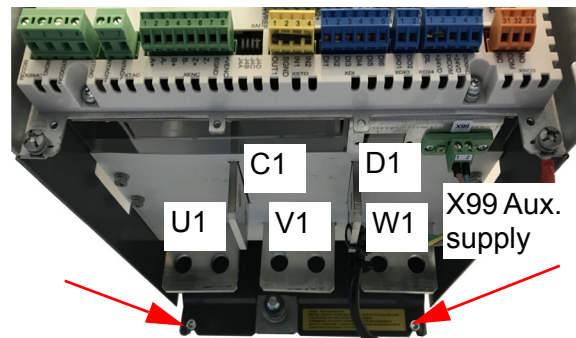

Mounting the H7 power unit inside an enclosure

Cooling air inlet

The cooling fan takes the air from the back, left, right side and from the bottom of the converter module. View from:

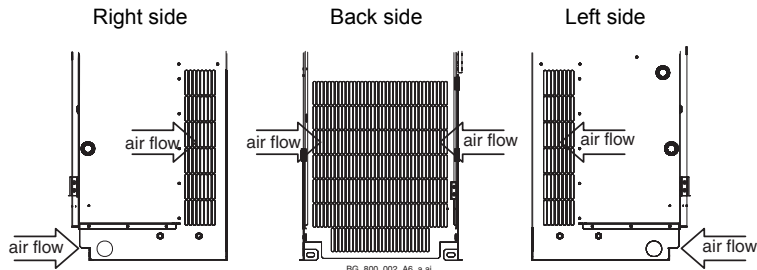

Free space around the converter module

Optimum Compromise

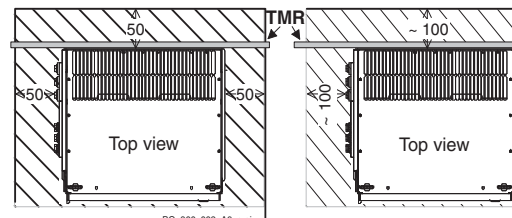

Cooling air outlet

To avoid circulating air inside the enclosure make sure the exhaust air leaves the enclosure.

Cable entries

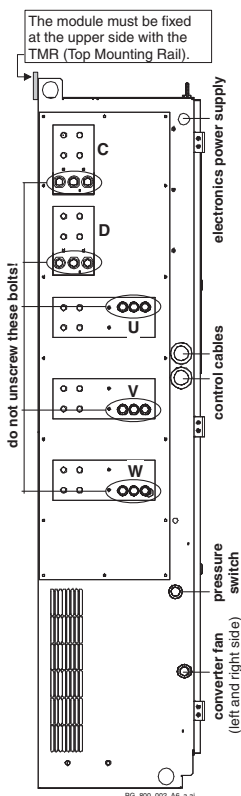

Power cable connection

The power cable connection is done via **option 3ADT786223**. This option consists of 5 rectangular copper busbars with screws. The mechanical details are shown in the figure below.

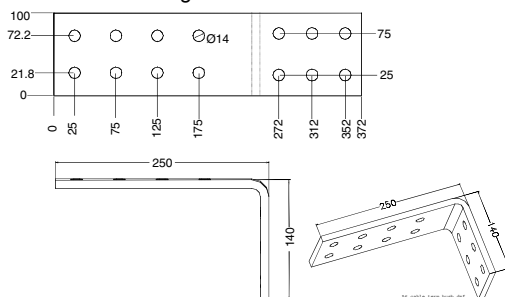

When mounting the rectangular busbars or connecting cables directly please make sure the correct bolts are used. The converter module is equipped with threaded holes at its left side. Because of that the length of the screw threads is limited to 35 mm (see drawing below).

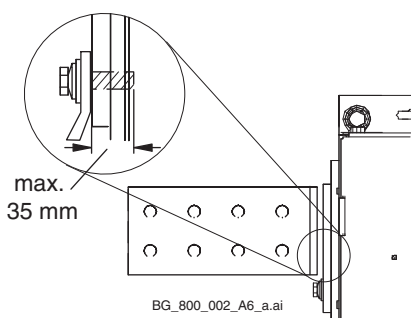

The figure below gives an example, how the rectangular busbars can be mounted in case all cable connections are made at the left side of the converter module. This results in four layers of power cables.

In case the AC or DC connection or perhaps both of them have to be made at the right side of the converter module use the space behind the converter. Move the power terminals via rectangular busbars to the final connection points. In this case the busbars need to be fixed at the enclosure, not at the converter module! The figures below give a rough example, how connections can be made.

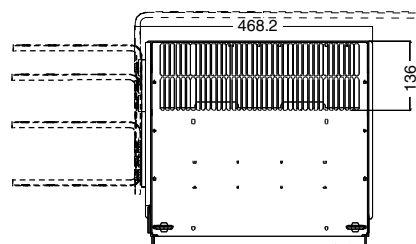
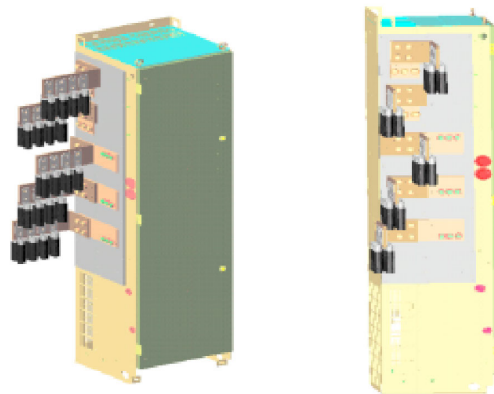

Example right side connection

Mounting the H8 power unit inside an enclosure

Cooling air inlet

The cooling fan takes the air from the back, left, right side and from the bottom of the converter module.

View from:

Front side

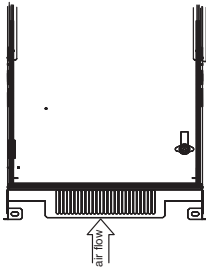

Left / Right side

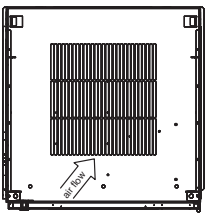
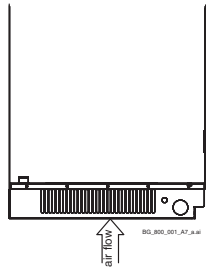

View from bottom

Free space around the converter module

Do not place the converter module in a corner. In case the fan cannot take the air through the bottom plate of the enclosure none of the remaining entries must be blocked.

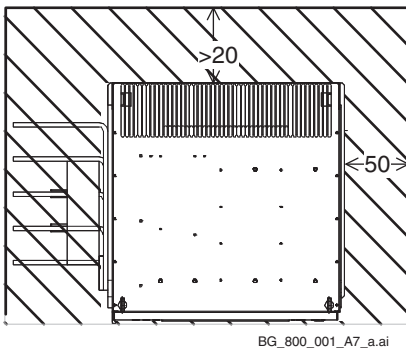

BG_800_001_A7_a.ai

Air entry through the bottom plate

Make sure the converter module gets clean air, because there is no air filter in front of the converter fan.

Cooling air outlet

To avoid circulating air inside the enclosure make sure the exhaust air leaves the enclosure.

Cable entries

The cable entries are symmetric on both sides. Nevertheless only the entries on the left side should be used for cables connected to the electronic power supply (SDCS-POW-H01) or the controller board (SDCS-CON-H01).

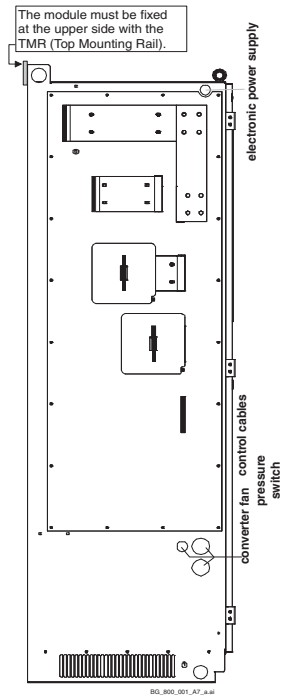

Internal cable ducts are used for the snubber cables. Do not use these cable ducts for other cables e.g. process signals!

Use cable ties to fix the fan cable!

Fasten all cables, otherwise the air flow from fan will destroy them!

Planning the electrical installation

Chapter overview

This chapter contains the instructions that must be followed when selecting the motor, cables, protections, cable routing and way of operation for the drive system. Always follow local regulations. This chapter applies to all DCS880 converter modules.

Attention:

If the recommendations given by ABB are not followed, the drive may experience problems not covered by warranty. See also [Technical guide](#).

Options

Line reactors (L1)

For armature and field supply.

When thyristor converters operate, the line voltage is short-circuited during commutation from one thyristor to the next. This operation causes voltage dips in the mains PCC (point of common coupling). For the connection of a power converter system to the mains, one of the following configurations applies:

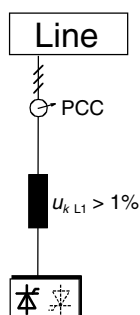

Configuration A

When using a converter, a minimum of impedance is required to ensure proper performance of the snubber circuit. Use a line reactor to meet this minimum impedance requirement. The value must therefore not drop below 1 % u_k (relative impedance voltage). It should not exceed 10 % u_k , due to considerable voltage drops at the converters outputs.

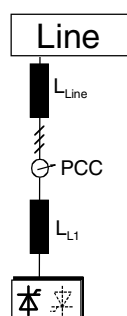

Configuration B

If special requirements have to be met at the PCC (standards like EN 61 800-3, DC and AC drives at the same line, etc), different criteria must be applied for selecting a line reactor. These requirements are often defined as a voltage dip in percent of the nominal supply voltage. The combined impedance of $Z_{L_{line}}$ and Z_{L1} constitute the total series impedance of the installation. The ratio between the line impedance and the line reactor impedance determines the voltage dip at the PCC. In such cases, line chokes with an impedance around 4 % are often used.

Example calculation with $u_{kL_{line}} = 1\%$ and $u_{kL1} = 4\%$:

Voltage dip = $Z_{L_{line}} / (Z_{L_{line}} + Z_{L1}) = 20\%$. Detailed calculations see [Technical guide](#).

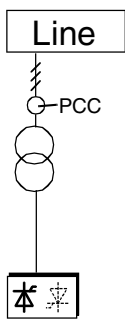

Configuration C

If a dedicated transformer / isolation transformer is used, it is possible to comply with certain connecting conditions per Configuration B without using an additional line reactor. The condition described in Configuration A will then likewise be satisfied, since the u_k is $> 1\%$.

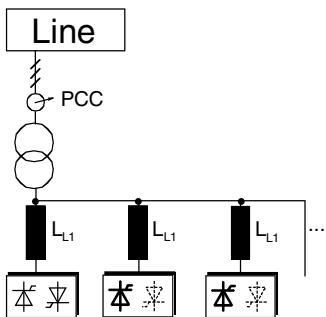

Netzdr_g.dsf

Configuration C1

If 2 or more converters should be supplied by one transformer the final configuration depends on the number of drives in use and their power capability. Configuration A or B has to be used, if the drive system consists of any of the converters H1, H2, H3, H4, H5, H6, H7, H8. In case if **only** two converters of type H8 are used no line reactors are necessary because the design of these converters allows that configuration.

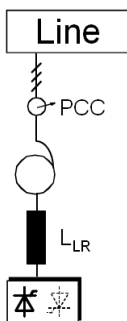

Configuration D

In the case of thyristor converters, frequently transformers are used for voltage matching. When using an autotransformer for this purpose, additionally install a line reactor, because the u_k of commonly used autotransformers is too small. In case of converters size H1 ... H5 the allowed voltage at the PCC is $\leq 600 V_{AC}$.

Line reactors for converters

The line reactors listed in table below

- have been sized to the units nominal current and frequency (50 / 60 Hz)
- are independent of converter's voltage classification; at some converter types the same line choke is used up to 690 V line voltage
- are based on a duty cycle
- can be used for DCS880 as armature converter as well as field converter, but rated line choke current must be considered.

For further information see also [Technical guide](#).

Line reactors (L_1) Selection

Size	DCS Type		Line reaktor	Design	Line reaktor	Design
	400 V... 690 V		($u_k = 1\%$)	Fig.	($u_k = 4\%$)	Fig.
	2-Q Converter	4-Q Converter				
H1	DCS880-S01-0020-04/05	DCS880-S02-0025-04/05	ND01	1	ND401	4
	DCS880-S01-0045-04/05	DCS880-S02-0050-04/05	ND02	1	ND402	4
	DCS880-S01-0065-04/05	DCS880-S02-0075-04/05	ND04	1	ND403	5
	DCS880-S01-0090-04/05	DCS880-S02-0100-04/05	ND06	1	ND404	5
H2	DCS880-S01-0135-04/05	DCS880-S02-0150-04/05	ND06	1	ND405	5
	DCS880-S01-0180-04/05	DCS880-S02-0200-04/05	ND07	2	ND406	5
	DCS880-S01-0225-04/05	DCS880-S02-0250-04/05	ND07	2	ND407	5
	DCS880-S01-0270-04/05	DCS880-S02-0300-04/05	ND09	2	ND408	5
H3	DCS880-S01-0290-06	DCS880-S02-0320-06	ND08	2	On request	-
	DCS880-S01-0315-04/05	DCS880-S02-0350-04/05	ND09	2	ND408	5
	DCS880-S01-0405-04/05	DCS880-S02-0450-04/05	ND10	2	ND409	5
	DCS880-S01-0470-04/05	DCS880-S02-0520-04/05	ND10	2	ND410	5
H4	DCS880-S01-0590-06	DCS880-S02-0650-06	ND13	3	On request	-
	DCS880-S01-0610-04/05	DCS880-S02-0680-04/05	ND12	2	ND411	5
	DCS880-S01-0740-04/05	DCS880-S02-0820-04/05	ND13	3	ND412	5
	DCS880-S01-0900-04/05	DCS880-S02-1000-04/05	ND13	3	ND413	5
H5	DCS880-S01-1190-04/05	DCS880-S02-1190-04/05	ND14	3	On request	-
H6	DCS880-S01-0900-06/07	DCS880-S02-0900-06/07	ND13	3	On request	-
	DCS880-S01-1200-04/05	DCS880-S02-1200-04/05	ND14	3	On request	-
	DCS880-S01-1500-04/05/06/07	DCS880-S02-1500-04/05/06/07	ND15	3	On request	-
	DCS880-S01-2000-04/05	DCS880-S02-2000-04/05	ND16	3	On request	-
	DCS880-S01-2000-06/07	-	ND16 ①	3	On request	-
H7	DCS880-S01-1900-08	DCS880-S02-1900-08	ND17 ②	-	-	-
	DCS880-S01-2050-05/06/07	DCS880-S02-2050-05/06/07	ND17 ②	-	-	-
	DCS880-S01-2500-04/05/06/07/08	DCS880-S02-2500-04/05/06/07/08	ND17 ②	-	-	-

① With forced cooling (1 m/s)

② On request

Line reactors (details see chapter [Line reactors IEC](#))

Fig. 1



Fig. 2



Fig. 3

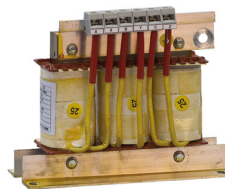

Fig. 4



Fig. 5

Semiconductor fuses (F1)

Aspects of fusing for the armature and field circuit of DC drives.

Unit configuration

Protection elements such as fuses or overcurrent trip circuits are required in all cases to protect against further damage. In some configurations, this will entail the following questions:

1. Where to place which protective element?
2. In the event of what faults will the element in question provide protection against damage?

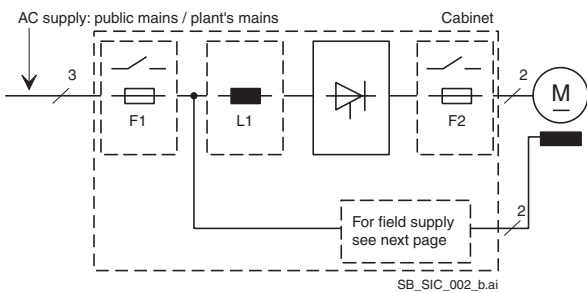

The figure shows the arrangement of the switch-off elements in the armature-circuit. Further information is available in the [Technical guide](#).

Conclusion for the armature circuit

Never use standard fusing instead of semiconductor fusing in order to save money on the installation. In the event of a fault condition, the small amount of money saved can cause the semiconductors or other devices to explode and cause fires. Adequate protection against short circuit and earth fault, as depicted in the EN50178 standard, is possible only with appropriate semiconductor fuses. Use DC fuses (2 of them) for all regenerative drives to protect the motor in case of a fault during regeneration. DC fuses must be rated for the same current and voltage as AC fuses, thus follows DC fuses = AC fuses.

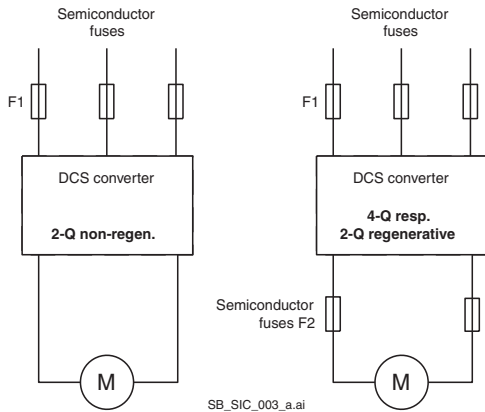

Typical selection of DC fuses / high speed DC-breakers.

Operation mode	H1 ... H4	H5 ... H8
No regeneration	-	-
Seldom regeneration (< 10 %)	-	-
Regeneration (10 % ... 30 %)	DC fuses recommended	High speed DC-breaker recommended
Often regeneratio (> 30 %)	DC fuses strongly recommended	High speed DC-breaker strongly recommended

Conclusion for the field circuit

Basically, similar conditions apply for both field and armature circuit. Depending on the converter used (half-controlled bridge, fully controlled bridge), some of the fault sources may not always be applicable. Due to special system conditions, such as supply via an autotransformer or an isolating transformer, new protection conditions may occur.

The following configurations are very often used:

In contrast to the armature circuit, fuses are **never** used on the DC side of the field circuit, since a fuse trip might lead to additional damage e.g. small, but long-lasting overcurrent, contact problems, explosions, fires, etc.

Semiconductor fuses F3.1 (super-fast acting) should be used, in case of similar conditions compared to the armature circuit (4-Q operation). E.g. protection of the field circuit and the field winding.

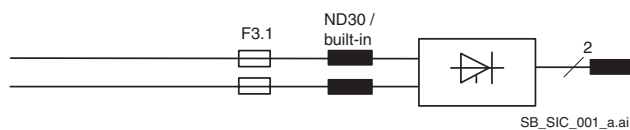

Configuration for field circuit.

Fuses F3.2 and F3.3 are used as line protectors and **cannot protect the field supply** unit. Only pure HRC fuses or miniature circuit-breakers must be used. Semiconductor fuses will be tripped, for example, by the transformer's inrush current.

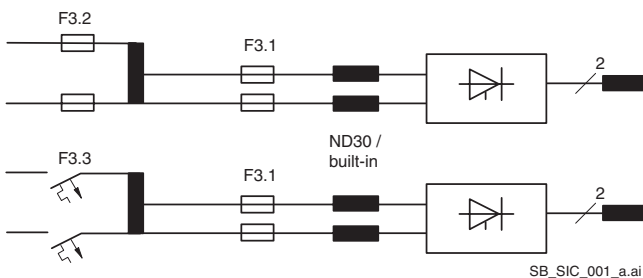

Configurations for field circuit.

Semiconductor fuses (F1) and fuse holders for armature circuit

The converters are subdivided into two groups:

- Unit sizes H1, H2, H3 and H4 with rated currents up to 1000 A require external fuses.
- In unit sizes H5, H6, H7 and H8 with rated currents from 900 A to 5200 A, branch fuses are internally installed (no additional external AC or DC fuses are needed).

The fourth column of the table below assigns the AC fuse to the unit. In case the converter should be equipped with DC fuses, use the same type of fuse as on the AC side.

Size	Converter type (2-Q)	Converter type (4-Q)	Fuse	Fuse holder	Fuse	Fuse holder
					North America	
H1	DCS880-S01-0020-04/05	DCS880-S02-0025-04/05	50A 660V UR	OFAX 00 S3L	FWP-50B	1BS101
	DCS880-S01-0045-04/05	DCS880-S02-0050-04/05	80A 660V UR	OFAX 00 S3L	FWP-80B	1BS101
	DCS880-S01-0065-04/05	DCS880-S02-0075-04/05	125A 660V UR	OFAX 00 S3L	FWP-125A	1BS103
	DCS880-S01-0090-04/05	DCS880-S02-0100-04/05	125A 660V UR	OFAX 00 S3L	FWP-125A	1BS103
H2	DCS880-S01-0135-04/05	DCS880-S02-0150-04/05	200A 660V UR	OFAX 1 S3	FWP-200A	1BS103
	DCS880-S01-0180-04/05	DCS880-S02-0200-04/05	250A 660V UR	OFAX 1 S3	FWP-250A	1BS103
	DCS880-S01-0225-04/05	DCS880-S02-0250-04/05	315A 660V UR	OFAX 2 S3	FWP-300A	1BS103
	DCS880-S01-0270-04/05	DCS880-S02-0300-04/05	500A 660V UR	OFAX 3 S3	FWP-300A	1BS103
H3	DCS880-S01-0315-04/05	DCS880-S02-0350-04/05	500A 660V UR	OFAX 3 S3	FWP-500A	1BS103
	DCS880-S01-0405-04/05	DCS880-S02-0450-04/05	700A 660V UR	OFAX 3 S3	FWP-700A	①
	DCS880-S01-0470-04/05	DCS880-S02-0520-04/05	700A 660V UR	OFAX 3 S3	FWP-700A	①
H4	DCS880-S01-0610-04/05	DCS880-S02-0680-04/05	900A 660V UR	3x 170H 3006	FWP-900A	①
	DCS880-S01-0740-04/05	DCS880-S02-0820-04/05	900A 660V UR	3x 170H 3006	FWP-900A	①
	DCS880-S01-0900-04/05	DCS880-S02-1000-04/05	1250A 660V UR	3x 170H 3006	FWP-1200A	①
H3	DCS880-S01-0290-06	DCS880-S02-0320-06	500A 660V UR	OFAX 3 S3	FWP-500A	①
H4	DCS880-S01-0590-06	DCS880-S02-0650-06	900A 660V UR	3x 170H 3006	FWP-900A	①

① No fuse holder is available; attach the fuses directly to the busbar.

Fuses and fuse holders for armature circuit (details see chapter [Fuses and fuse holders IEC](#)).

Fuses (F3.x) and fuse holders for field circuit

Depending on the protection strategy different types of fuses are used. The fuses can be sized according to the maximum field current. In this case take the fuse, which fits to the rated field current levels. If the field converter is connected to two phases of a network, two fuses should be used. In case the unit is connected to one phase and neutral only one fuse at the phase can be used. The table below lists the fuse currents depending on the table above.

Field converter type	Field current	F3.1	F3.2	F 3.3
DCF803-0016	$I_F \leq 6 \text{ A}$	10 A 660 V UR ①	OFAA 00 H10	10 A
FEX-425-Int ①	$I_F \leq 12 \text{ A}$	16 A 660 V UR ①	OFAA 00 H16	16 A
DCF803-0035	$I_F \leq 16 \text{ A}$	25 A 660 V UR ①	OFAA 00 H25	25 A
DCF803-0050				
DCF804-0050				
FEX-425-Int ①	$I_F \leq 25 \text{ A}$	50 A 660 V UR ①	OFAA 00 H50	35 A
DCF803-0035				
DCF803-0050				
DCF804-0050				
DCF803-0035	$I_F \leq 35 \text{ A}$			50 A
DCF803-0050				
DCF804-0050				
DCF803-0050	$I_F \leq 50 \text{ A}$	80 A 660 V UR	OFAA 00 H80	63 A
DCF804-0050				
DCF803-0060	$I_F \leq 60 \text{ A}$			80 A
DCF804-0060				
Type of protection elements		Semiconductor fuse fuse holder OFAX 00 S3L	LV HRC type for 690 V, fuse holder OFAX 00 S3L	Circuit breaker for 500 V or 690 V

① Fuse (F3.1) KTK25 included in FEX-425-Int package. H5 field fuses are external. H6 field fuses are internal. Fuses and fuse holders for the field circuit.

Single-phase autotransformer (T3) for field circuit (adapt voltage)

The field converters insulation voltage is higher than its rated voltage (see chapter [Accessories](#)). This provides the possibility in systems with more than 500 V mains voltage to supply the field converter directly. An autotransformer is used to match the mains voltage to the field voltage. Moreover, the autotransformer reduces the voltage ripple. Different autotransformer types (primary voltages from 400 ... 500 V and from 525 ... 690 V) with several rated currents are available.

Field converter type	Field current	Autotransformer type
DCF803-0016 FEX-425-Int DCF803-0035 DCF803-0050 DCF804-0050	$I_F \leq 6 \text{ A}$ $I_F \leq 12 \text{ A}$ $I_F \leq 16 \text{ A}$	$U_{\text{prim}} = \leq 500 \text{ V}$ T 3.01 T 3.02 T 3.03
FEX-425-Int DCF803-0035 DCF803-0050 DCF804-0050	$I_F \leq 30 \text{ A}$	T 3.04
DCF803-0050 DCF804-0050	$I_F \leq 50 \text{ A}$	T 3.05
DCF803-0060 DCF804-0060	$I_F \leq 60 \text{ A}$	T 3.16 (on request)
DCF803-0016 FEX-425-Int DCF803-0035 DCF803-0050 DCF804-0050	$I_F \leq 6 \text{ A}$ $I_F \leq 12 \text{ A}$ $I_F \leq 16 \text{ A}$	$U_{\text{prim}} = \leq 600 \text{ V}$ T 3.11 T 3.12 T 3.13
FEX-425-Int DCF803-0035 DCF803-0050 DCF804-0050	$I_F \leq 30 \text{ A}$	T 3.14
DCF803-0050 DCF804-0050	$I_F \leq 50 \text{ A}$	T 3.15
DCF803-0060 DCF804-0060	$I_F \leq 60 \text{ A}$	T 3.16 (on request)
DCF803-0050 DCF804-0050	$I_F \leq 6 \text{ A}$ $I_F \leq 12 \text{ A}$ $I_F \leq 16 \text{ A}$ $I_F \leq 30 \text{ A}$ $I_F \leq 50 \text{ A}$	$U_{\text{prim}} = \leq 690 \text{ V}$ T 3.11 T 3.12 T 3.13 T 3.14 T 3.15
DCF803-0060 DCF804-0060	$I_F \leq 60 \text{ A}$	T 3.16 (on request)

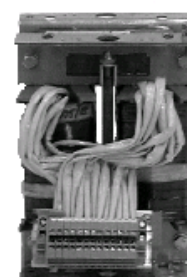
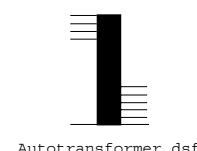

Autotransformer (T3)

Autotransformer data, details see chapter [Autotransformer \(T3\)](#).

Line reactors for single- and 3-phase connection of field converters

Field converters DCF803-0016, FEX-425-Int and DCF803-0035 need additional external line reactors. Field converters DCF803-0050, DCF804-0050, DCF803-0060 and DCF804-0060 do **not** need additional line reactors since they already have internal line reactors.

Field converter type	Field current	Line reactor type			
		IEC		US	
		Single-phase	3-phase	Single-phase	3-phase
DCF803-0016 FEX-425-Int. DCF803-0035	$I_F \leq 16 \text{ A}$	ND30	ND401*	KLR 45 CTB*	
FEX-425-Int. DCF803-0035	$I_F \leq 25 \text{ A}$	ND402*			
DCF803-0035	$I_F \leq 35 \text{ A}$				

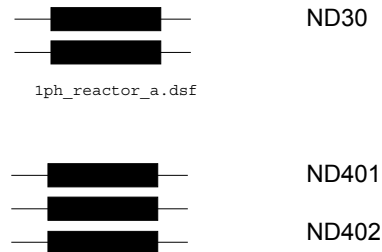

* 3-phase operation or single-phase operation

Line reactors (details see chapter [Line reactors IEC](#)).

Auxiliary transformer (T2) for electronic system / fan supply

The converter requires various auxiliary voltages, e.g. the unit's electronics require 115 V or 230 V single-phase. The fans require 230 V single-phase or 400 V / 460 V / 500 V 3-phases, according to their size. The auxiliary transformer (T2) is designed to supply the unit's electronic system and all the single-phase fans for converter sizes H4 ... H6.



Input voltage: 380 ... 690 V single-phase; 50 / 60 Hz
 Output voltage: 115 / 230 V single-phase
 Power: 1400 VA

Auxiliary transformer data, details see chapter [Auxiliary transformer \(T2\)](#).

EMC filters (E1)

Filter in a grounded line (earthed TN or TT network)

The filters are suitable for grounded lines only, for example in public European 400 V_{AC} lines. According to EN 61800-3 filters are not needed in insulated industrial networks with own supply transformers. Furthermore they could cause safety risks in such floating lines (IT networks). According to EN 61800-3 filters are not needed in industrial zone (Second Environment) for DCS880 drives above 100 A_{DC} rated current. For rated currents below 100 A_{DC} the filter requirement is identical to Light Industry (First Environment).

Three-phase filters

EMC filters are necessary to fulfil the standard for emitted interference if a converter shall be run at a public low voltage line, in Europe for example with 400 V_{AC}. Such lines have a grounded neutral conductor. ABB offers suitable three-phase filters for 400 V_{AC}. For 440 V_{AC} public low voltage lines outside Europe 500 V_{AC} filters are available. Optimize the filters for the real motor currents:

$I_{\text{Filter}} = 0.8 \cdot I_{\text{MOT max}}$; the factor 0.8 respects the current ripple.

Lines with 500 V_{AC} up to 1000 V_{AC} are not public. They are local networks inside factories, and they do not supply sensitive electronics. Therefore, converters do not need EMC filters if they shall run with 500 V_{AC} and more.

Size	Converter type (2-Q)	I _{DC} [A]	Converter type (4-Q)	I _{DC} [A]	Filter type for D = 4	Filter type for D = 5
H1	DCS880-S01-0020-0d	20	DCS880-S02-0025-0d	25	NF3-440-25	NF3-500-25
	DCS880-S01-0045-0d	45	DCS880-S02-0050-0d	50	NF3-440-50	NF3-500-50
	DCS880-S01-0065-0d	65	DCS880-S02-0075-0d	75	NF3-440-64	NF3-500-64
	DCS880-S01-0090-0d	90	DCS880-S02-0100-0d	100	NF3-440-80	NF3-500-80
H2	DCS880-S01-0135-0d	135	DCS880-S02-0150-0d	150	NF3-440-110	NF3-500-110
	DCS880-S01-0180-0d	180	DCS880-S02-0200-0d	200	NF3-500-320	NF3-500-320
	DCS880-S01-0225-0d	225	DCS880-S02-0250-0d	250	NF3-500-320	NF3-500-320
	DCS880-S01-0270-0d	270	DCS880-S02-0300-0d	300	NF3-500-320	NF3-500-320
H3	DCS880-S01-0315-0d	315	DCS880-S02-0350-0d	350	NF3-500-320	NF3-500-320
	DCS880-S01-0405-0d	405	DCS880-S02-0450-0d	450	NF3-500-600	NF3-500-600
	DCS880-S01-0470-0d	470	DCS880-S02-0520-0d	520	NF3-500-600	NF3-500-600
H4	DCS880-S01-0610-0d	610	DCS880-S02-0680-0d	680A	NF3-500-600	NF3-500-600
	DCS880-S01-0740-0d	740	—	—	NF3-500-600	NF3-500-600
	—	—	DCS880-S02-0820-0d	820	NF3-690-1000 ①	NF3-690-1000 ①
	DCS880-S01-0900-0d	900	DCS880-S02-1000-0d	1000	NF3-690-1000 ①	NF3-690-1000 ①
H5	DCS880-S01-1190-0d	1190	DCS880-S02-1190-0d	1190	NF3-690-1000 ①	NF3-690-1000 ①
H6	DCS880-S01-0900-0d	900	DCS880-S02-0900-0d	900	NF3-690-1000 ①	NF3-690-1000 ①
	DCS880-S01-1200-0d	1200	DCS880-S02-1200-0d	1200	NF3-690-1000 ①	NF3-690-1000 ①
	DCS880-S01-1500-0d	1500	DCS880-S02-1500-0d	1500	NF3-690-1600 ①	NF3-690-1600 ①
	DCS880-S01-2000-0d	2000	DCS880-S02-2000-0d	2000	NF3-690-1600 ①	NF3-690-1600 ①
H7		≤ 3000		≤ 3000	NF3-690-2500 ①	NF3-690-2500 ①

① EMC filter on request.

EMC filters

Further information is available in the [Technical guide](#):

The paragraphs below describe selection of the electrical components in conformity with the EMC Guideline. The aim of the EMC Guideline is, as the name implies, to achieve electromagnetic compatibility with other products and systems. The guideline ensures that the emissions from the product concerned are so low that they do not impair another product's interference immunity.

In the context of the EMC Guideline, two aspects must be borne in mind:

- the product's interference immunity and

- the product's actual emissions.

The EMC Guideline expects EMC to be taken into account when a product is being developed; however, EMC cannot be designed in, it can only be quantitatively measured.

Note on EMC conformity:

The conformity procedure is the responsibility of both the power converter's supplier and the manufacturer of the machine or system concerned, in proportion to their share in expanding the electrical equipment involved.

First environment (residential area with light industry) with PDS category C2	
Not applied, since category C1 (general distribution sales channel) excluded	
Not applicable	Satisfied
Satisfied	

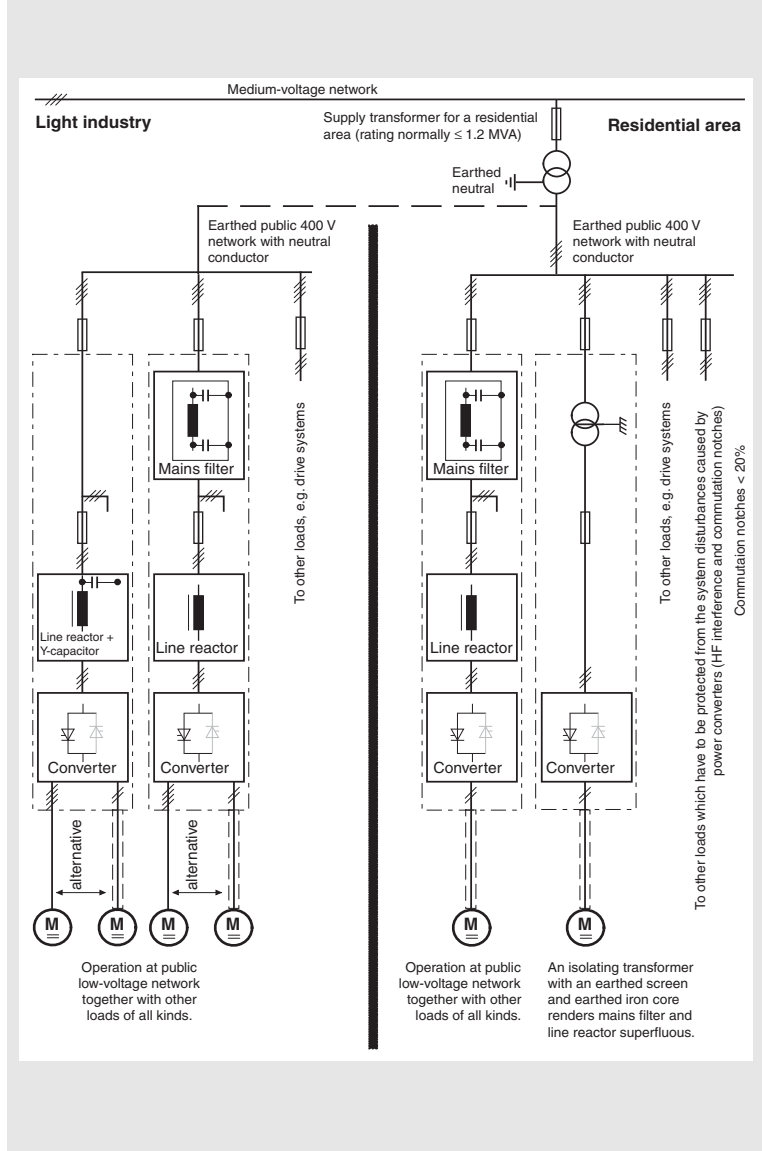
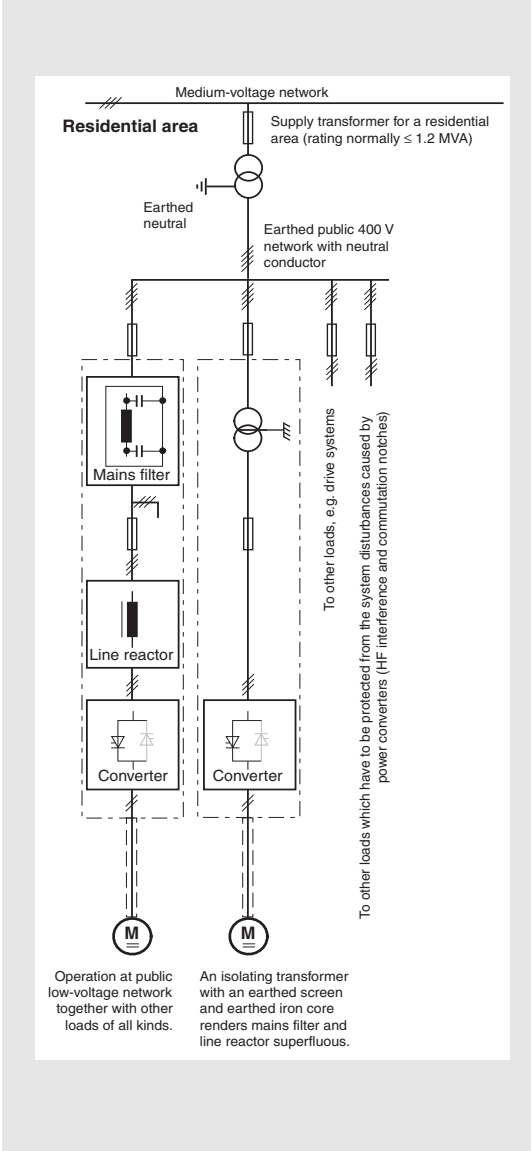

For compliance with the protection objectives of the German EMC Act (EMVG) in systems and machines, the following EMC standards must be satisfied:

Product Standard EN 61800-3

EMC standard for drive systems (PowerDriveSystem), interference immunity and emissions in residential areas, enterprise zones with light industry and in industrial facilities.

This standard must be complied with in the EU for satisfying the EMC requirements for systems and machines!

For emitted interference, the following apply:

EN 61000-6-3 Specialised basic standard for emissions in **light industry** can be satisfied with special features (mains filters, screened power cables) in the lower rating range *(EN 50081-1).

EN 61000-6-4 Specialised basic standard for emissions in **industry** *(EN 50081-2).

For interference immunity, the following apply:

EN 61000-6-1 Specialised basic standard for interference immunity in **residential areas** *(EN 50082-1).

EN 61000-6-2 Specialised basic standard for interference immunity in **industry**. If this standard is satisfied, then the EN 61000-6-1 standard is automatically satisfied as well *(EN 50082-2).

* The old generic standards are given in brackets

Second environment (industry) with PDS categories C3, C4			Standards
Not applicable			EN 61800-3
Satisfied			EN 61000-6-3
On customer's request		Satisfied	EN 61000-6-4
Satisfied			EN 61000-6-2
			EN 61000-6-1

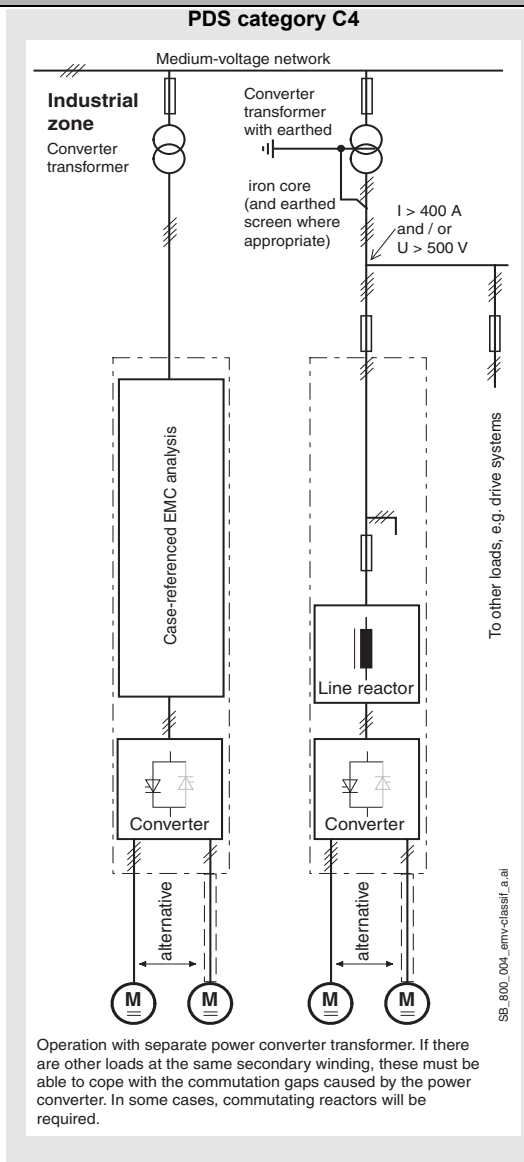
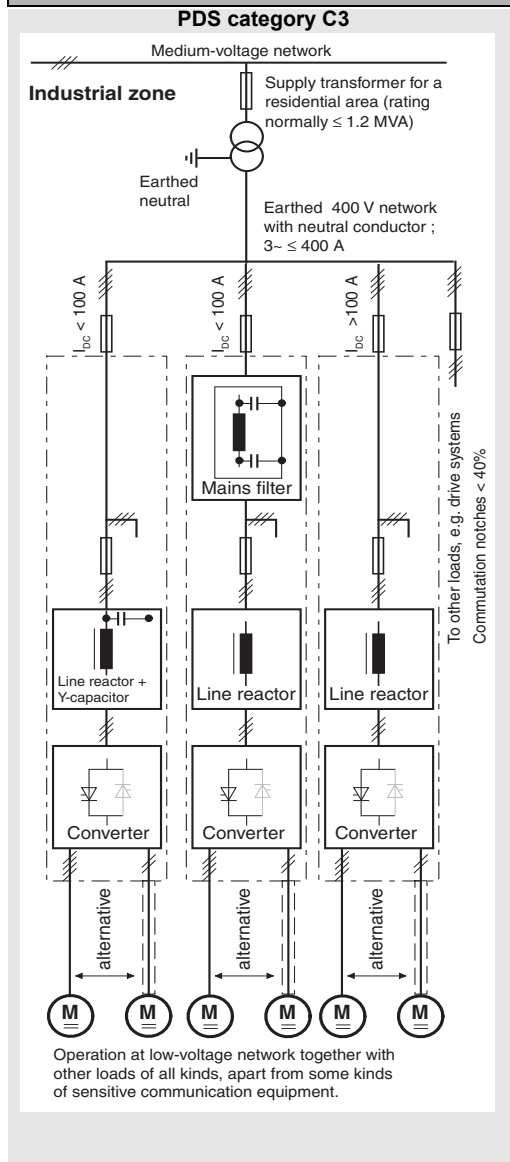

Classification

The following overview utilises the terminology and indicates the action required in accordance with Product Standard **EN 61800-3**

For the DCS880 series, the limit values for emitted interference are complied with, provided the measure indicated is carried out. PDS of category C2 (formerly restricted distribution in first environment) is intended to be installed and commissioned only by a professional (person or organization with necessary skills in installing and/or commissioning PDS including their EMC aspects).

For power converters without additional components, the following warning applies:

This is a product of category C2 under IEC 61800-3:2004. In a domestic/residential environment this product may cause radio interference in which case supplementary mitigation measures may be required.

The field supply is not depicted in this overview diagram. For the field current cables, the same rules apply as for the armature-circuit cables.

Legend

	Screened cable
	Unscreened cable with restriction

Converters size H1 ... H4 configuration using an OnBoard field exciter

Wiring the drive according to this diagram offers the highest degree of monitoring functions done by the drive.

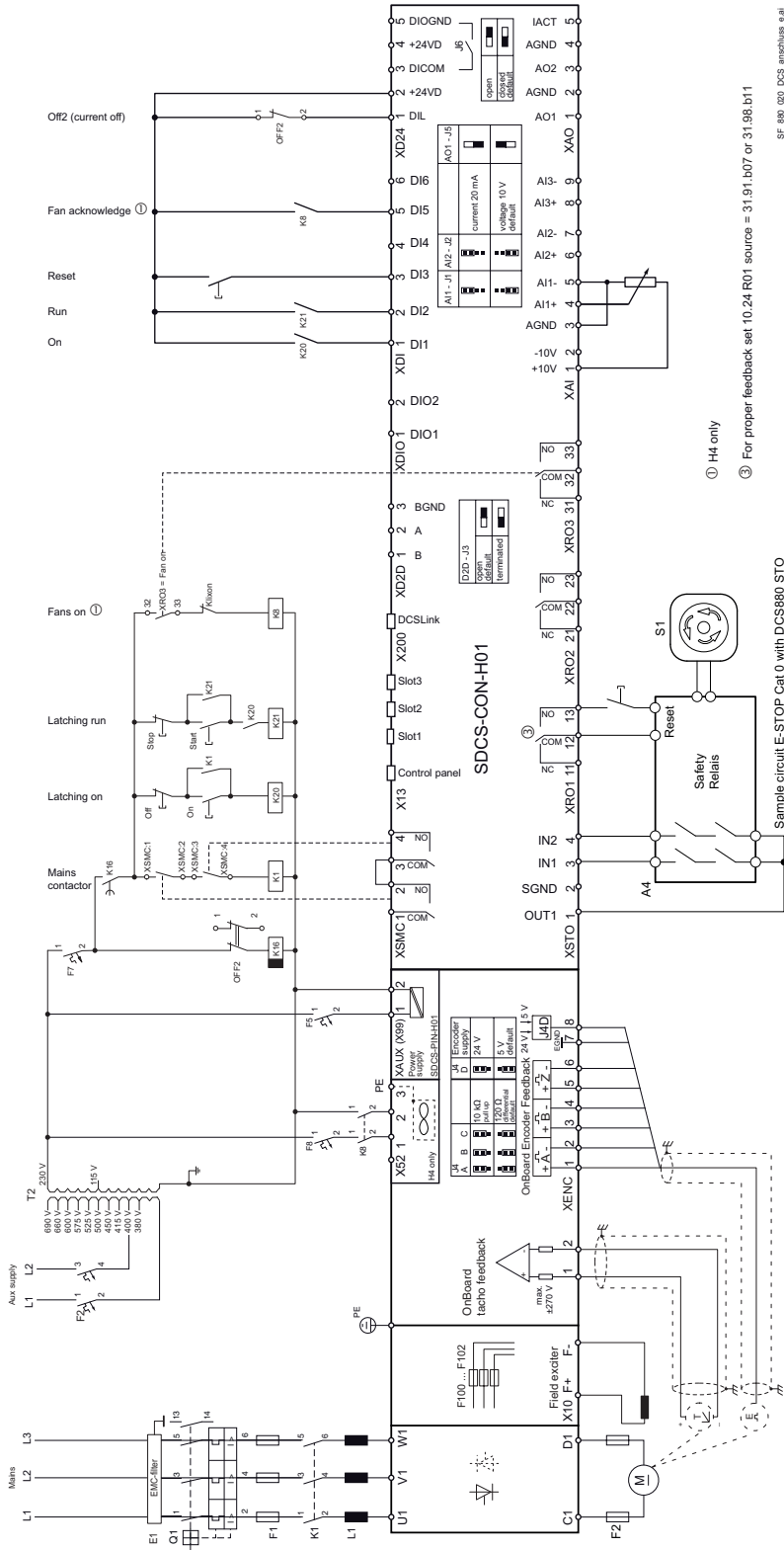

Converters size H5 configuration using FEX-425-Int field exciter

Wiring the drive according to this diagram offers the highest degree of monitoring functions done by the drive. Field converters FEX-425-Int are equipped with their own synchronization and must be supplied from independent mains supply voltage max. 500 V (single-phase or 3-phase).

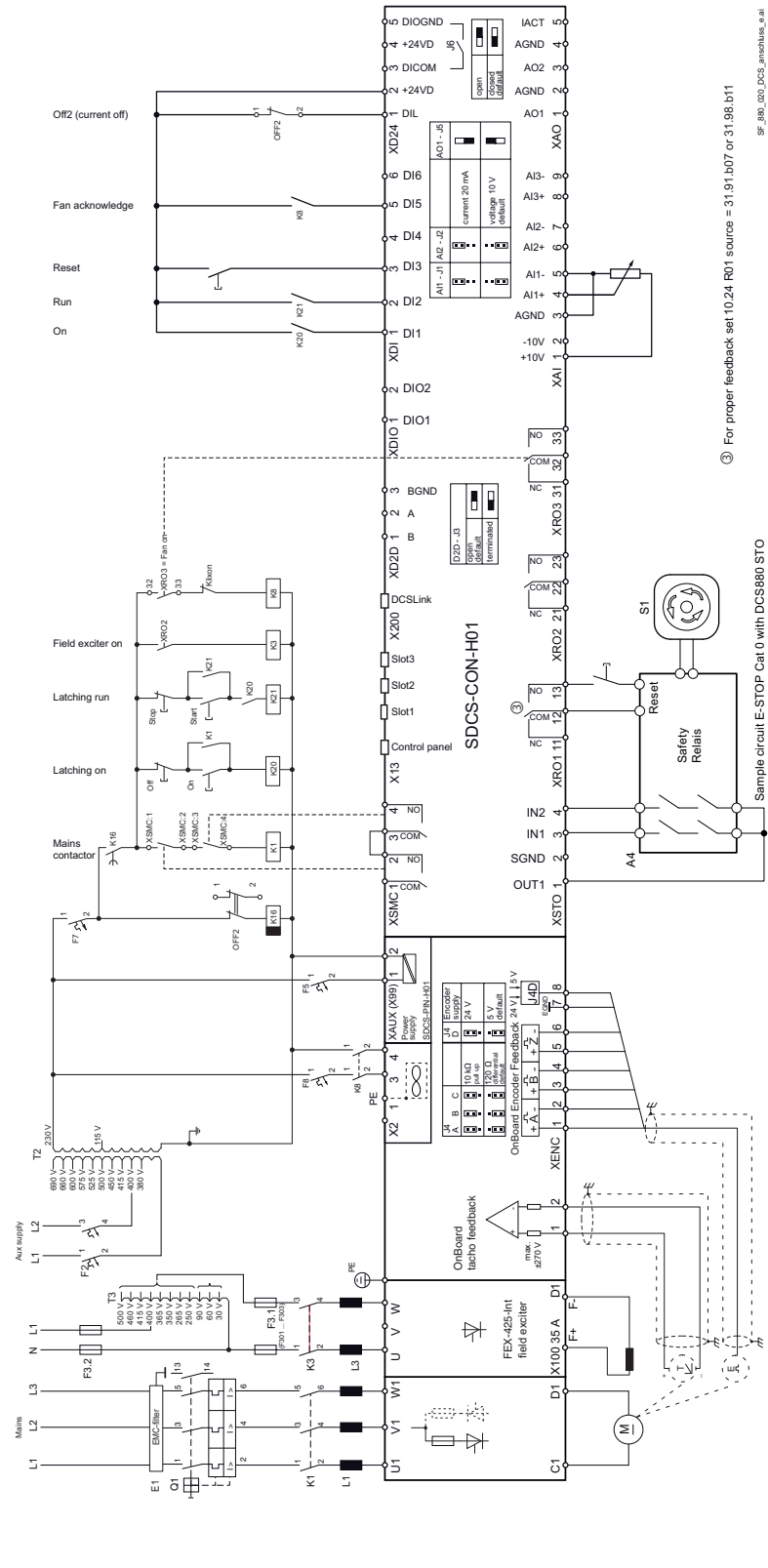

③ For proper feedback set 10.24 R01 source = 31.91.b07 or 31.98.b11

SF_880_020_DCS_innovatus_a.ai

Sample circuit E-STOP Cat 0 with DCS880 STO

Converters size H6 configuration using a FEX-425-Int field exciter

Wiring the drive according to this diagram offers the highest degree of monitoring functions done by the drive. Field converters FEX-425-Int are equipped with their own synchronization and must be supplied from independent mains supply voltage max. 500 V (single-phase or 3-phase).

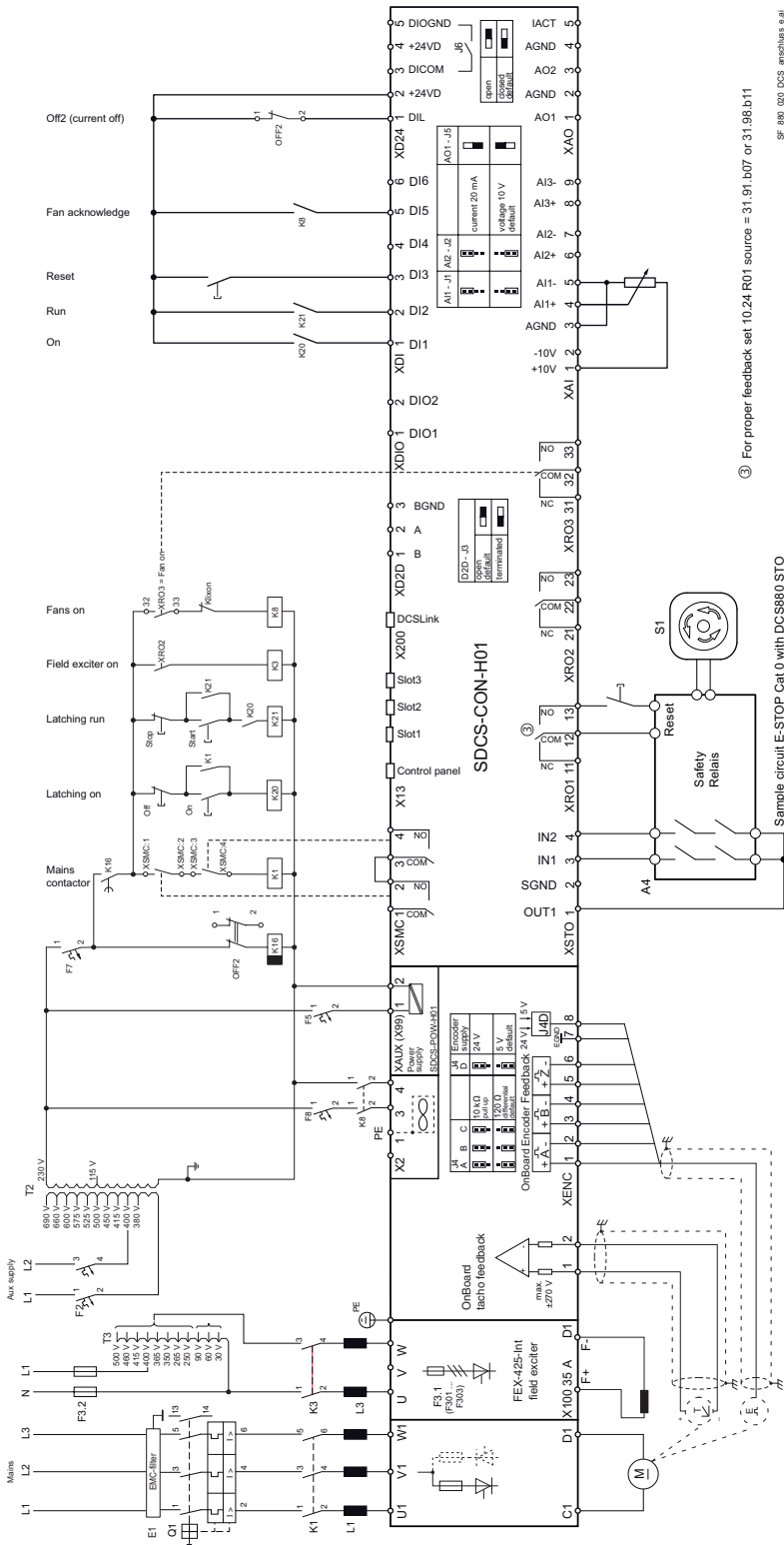

Converters size H1 ... H6 configuration using external field exciters DCF803, DCF804

Wiring the drive according to this diagram offers the highest degree of monitoring functions done by the drive. Field converters DCF803 / DCF804 are equipped with their own synchronization and must be supplied from independent mains supply voltage max. 500 V (single-phase or 3-phase).

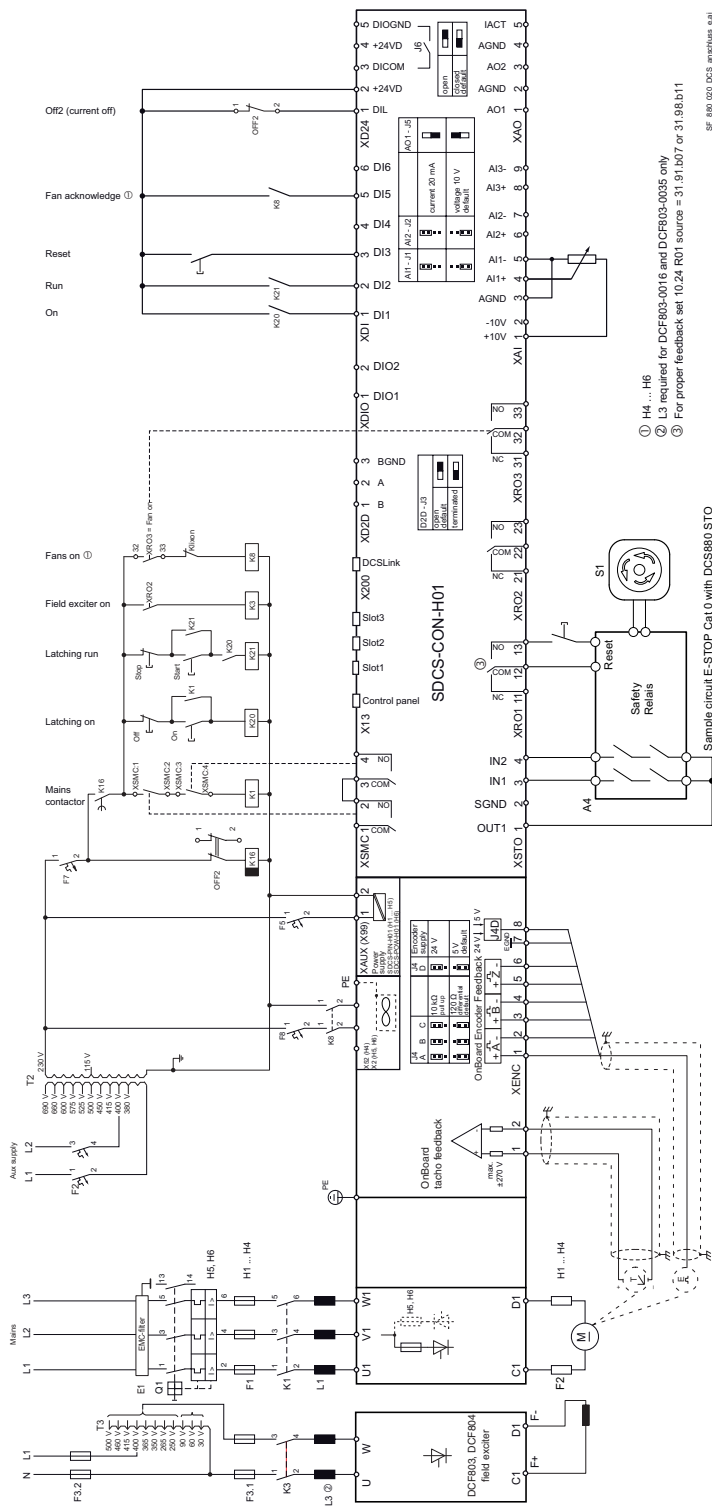

- ① H4 ... H6
- ② L3 required for DCF803-0016 and DCF803-0035 only
- ③ For proper feedback set 10.24 R01 source = 31.91.007 or 31.98.011

5F_380_003_DCS_mechan_en

Sample circuit E-STOP Cat 0 with DCS880 STO

Converters size H7 and H8 configuration using external field exciters DCF803, DCF804

Wiring the drive according to this diagram offers the highest degree of monitoring functions done by the drive. Field converters DCF803 / DCF804 are equipped with their own synchronization and must be supplied from independent mains supply voltage max. 500 V (single-phase or 3-phase).

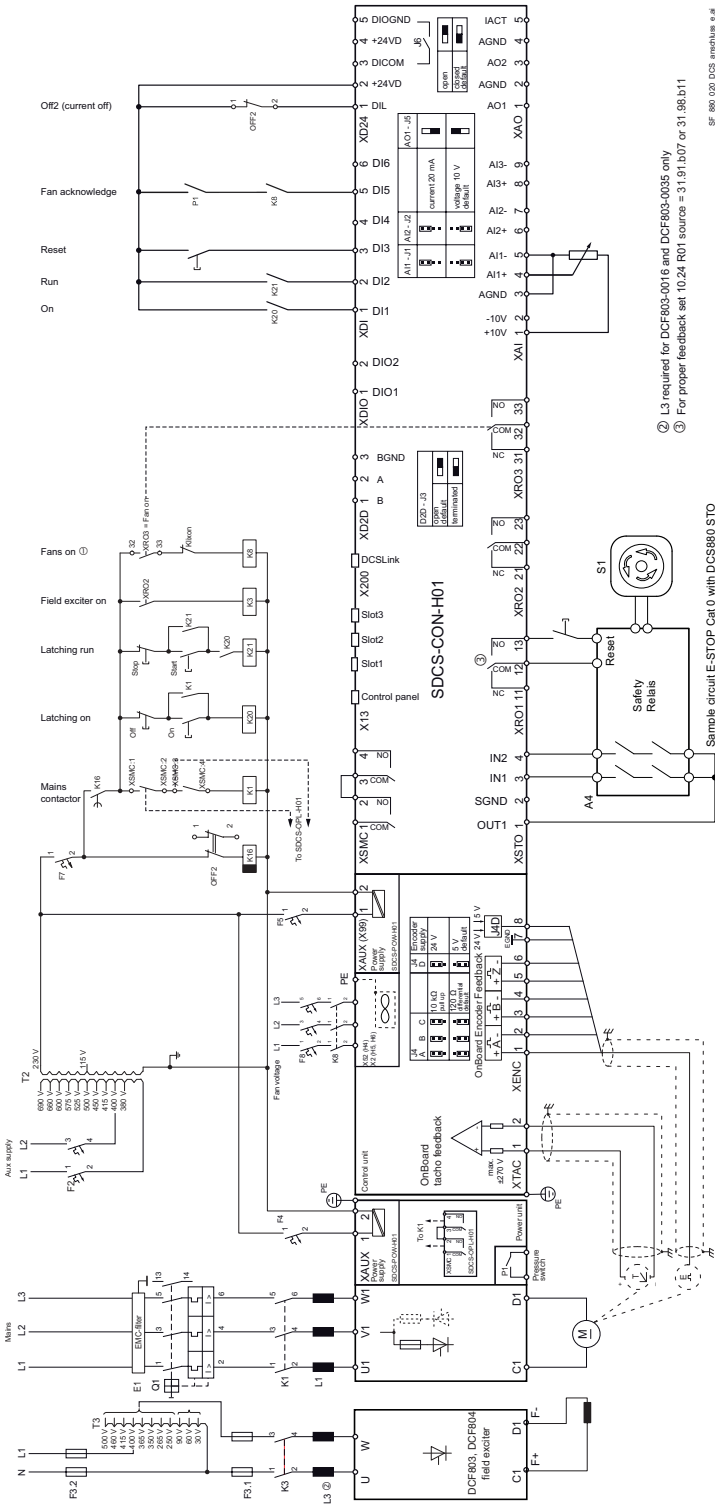

② L3 required for DCF803-0016 and DCF803-0035 only
③ For proper feedback set 10.24 R01 source = 31.91.007 or 31.98.011

SF_880_030_DCS_0mch_kat_e_01

Sample circuit E-STOP Cat 0 with DCS880 STO

Converters size H1 ... H3 as large field exciter

Wiring the drive according to this diagram offers the highest degree of monitoring functions done by the drive.

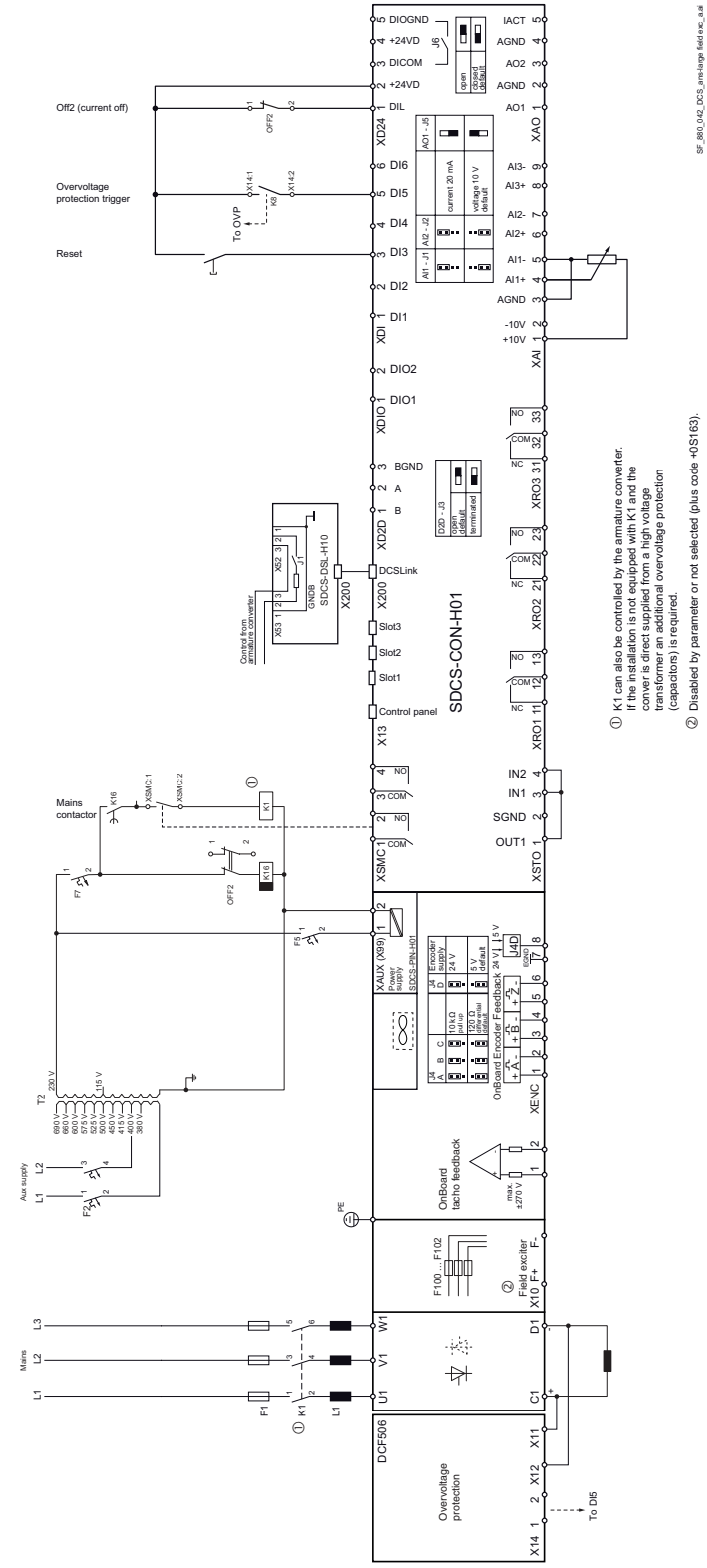

- ① K1 can also be controlled by the amature converter. If the installation is not equipped with K1 and the converter is direct supplied from a high voltage transformer, additional overvoltage protection (capacitors) is required.
- ② Disabled by parameter or not selected (plus code +0S1 63).

SF_880_042_DCS_inlarge field exc_01

Start, Stop and E-Stop control

The relay logic is splitted into four parts:

1: Generation of the On / Off and Start / Stop commands:

The commands represented by K20 and K21 (latching interface relays) can also be generated by a PLC and transferred to the terminals of the converter either by relays, using galvanic isolation or directly via 24 V signals.

There is no need to use hardwired signals. Transfer these commands via serial communication. Even a mixed solution can be realized by selecting different possibilities for the one or the other signal (see parameter groups 06 and 20):

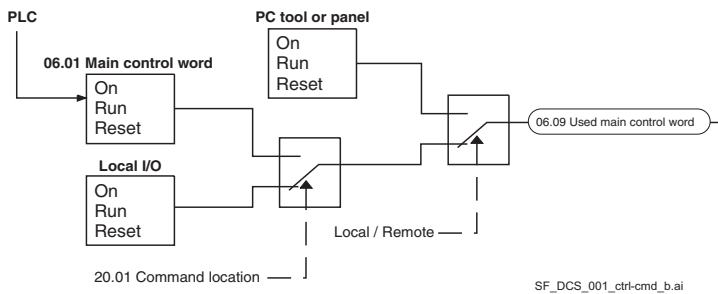

2: Generation of control and monitoring signals:

Control the mains contactor (K1) of the armature circuit by the relay contact of XSMC. The status of the drive and / or motor fans (K8) can be monitored by means of 20.38 Drive fan acknowledge source and 20.39 Motor fan acknowledge source.

3: Off2 (emergency off / electrical disconnect / fast current off) and Off3 (emergency stop):

Beside **On / Off** and **Start / Stop** the drive is equipped with two additional stop functions **Off2** and **Off3** according to Profibus standard.

Off3 is scalable via 21.03 Emergency stop mode to perform a stop according to category 1. Connect this function to the E-stop push button (off3) without any time delay. In case of 21.03 Emergency stop mode = Ramp stop the timer relay (K15) must be set longer than 23.23 Emergency stop time. For 21.03 Emergency stop mode = Coast stop the drive opens the mains contactor immediately.

Off2 switches the DC current off as fast as possible and prepares the drive to open the mains contactor or drop the mains supply. For a normal DC motor load the time to force the DC current to zero is below 20 ms. This function should be connected to all signals and safety functions opening the mains contactor. This function is important for 4-Q drives. Do not open mains contactor during regenerative current. The correct sequence is:

1. Switch off regenerative current.
2. Then open the mains contactor.

In case the E-stop push button is hit, the information is transferred to a digital input of the converter. In case 21.03 Emergency stop mode = Ramp stop or Torque limit the converter will decelerate the motor and then open the mains contactor. If the drive has not finished the function within the timer relay (K15) setting, the drive must get the command to switch off the current via timer relay (K16). After the timer relay (K16) has elapsed, the mains contactor is opened immediately, independent of the drive's status.

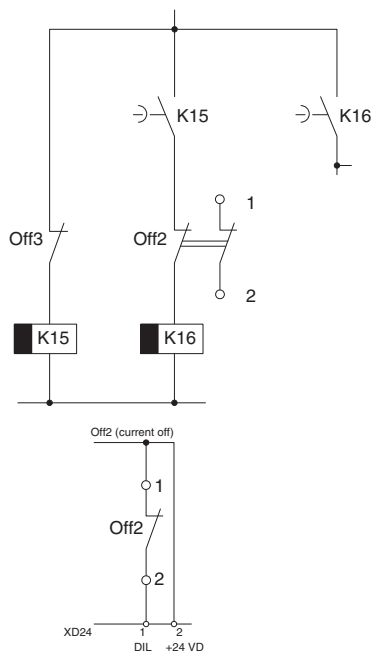

SF_CON4_001_E-stop_b.ai

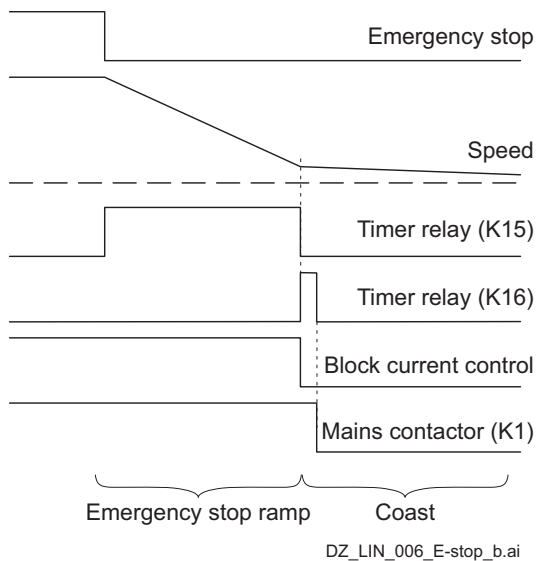

DZ_LIN_006_E-stop_b.ai

Emergency stop reaction

4:DC contactor (US style):

The DC contactor (US style) K1.1 is a special designed DC contactor with one normally closed contact for the dynamic braking resistor R_B and two normally open contacts for C1 and D1. The DC contactor should be controlled by 06.24.b10 Current controller status word 1. The acknowledge signal can be connected to either 20.34 Mains contactor acknowledge source, or 20.35 DC breaker acknowledge source. Use 20.33 Mains contactor control mode = DC contactor.

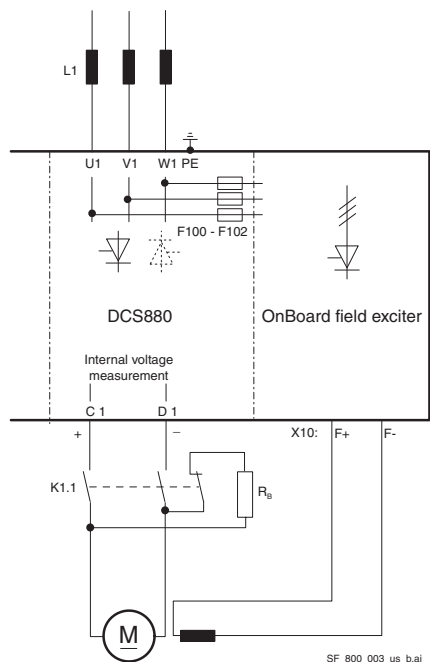

SF_800_003_us_b.ai

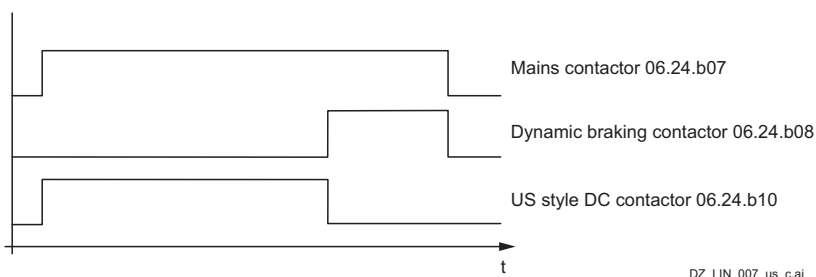

DZ_LIN_007_us_c.ai

	Internal DC voltage measurement	DC voltage measurement at the motor terminals
Without field weakening	20.44 Dynamic braking delay ≥ 0.1 s.	20.44 Dynamic braking delay ≤ -0.1 s.
With field weakening	Not allowed.	

Cooling fans

Fan assignment for DCS880

Converter type	Size	Configuration	Fan type	Airflow built in [m³/h]
DCS880-S0b-0045-04/05 ... DCS880-S0b-00100-04/05	H1	1	1 x 3110UL	57
DCS880-S0b-0135-04/05 ... DCS880-S0b-0300-04/05	H2	2	2 x AFB122	170
DCS880-S01-0290-06 DCS880-S02-0320-06 DCS880-S0b-0315-04/05 ... DCS880-S0b-0450-04/05	H3			
DCS880-S0b-0470-04/05 ... DCS880-S0b-0520-04/05				
DCS880-S01-0590-06 DCS880-S02-0650-06 DCS880-S0b-0610-04/05 ... DCS880-S0b-0820-04/05	H4	4	1 x W2E200 230 V; 1~	388
DCS880-S0b-0900-04/05 ... DCS880-S0b-1000-04/05			1 x W2E250 230 V; 1~	425
DCS880-S0b-1190-04/05	H5	5	R2E250-RB 230 V; 1~	918
DCS880-S0b-0900-0d ... DCS880-S0b-2000-0d	H6			850
DCS880-S0b-1900-0d ... DCS880-S0b-3000-0d	H7	6	GR28C-2DK 400 V / 500 V @ 50 Hz or 460 V @ 60 Hz	1700
DCS880-S0b-2050-dd ... DCS880-S0b-5200-dd	H8	7	GR35C-2DD 400 V @ 50 Hz or 460 V @ 60 Hz	4500

b = Bridge type

d = Rated AC voltage

Fan cable sizes and tightening torque connected at the fan terminals

Fan terminals are X52 for H4, X2 for H5/H6 and U1, V1, W1 for H7/H8.

Converter type	Flexible cable		Solid cable	
	max [mm²]	torque [Nm]	max [mm²]	torque [Nm]
DCS880-S0x-0610-dd ... DCS880-S0x-1000-dd	0.5 ... 1.5	0.5 ... 0.6	0.5 ... 1.0	0.5 ... 0.6
DCS880-S0x-1190-dd ... DCS880-S0x-2000-dd	0.5 ... 1.5	0.5 ... 0.6	0.5 ... 1.0	0.5 ... 0.6
DCS880-S0x-1900-dd ... DCS880-S0x-3000-dd	0.5 ... 1.5	Push in	0.5 ... 1.5	Push in
DCS880-S0x-2050-dd ... DCS880-S0x-5200-dd	0.5 ... 1.5	0.6 ... 0.8	0.5 ... 1.5	0.6 ... 0.8

d = Rated AC voltage

Fan Data for DCS880 (H1 ... H4)

Fan	3110UL	AFB122	W2E200		W2E250	
Rated voltage [V _{AC}]	24 V internal	24 V internal	230; 1~		230; 1~	
Tolerance [%]			+6 / -10		+6 / -10	
Frequency [Hz]			50	60	50	60
Power consumption [W]			64	80	135	185
Current consumption [A]			0.29	0.35	0.59	0.82
Blocking current [A]			< 0.7	< 0,8	< 0.9	< 0.9
Air flow [m ³ /h] freely blowing	50	190	925	1030	1860	1975
Max. ambient temperature [° C]	< 70	< 70	< 75		60	
Useful lifetime of grease	70,000 h/25°	100,000 h/25°	appr. 45,000 h/60°		appr. 40,000 h	
Protection	Internal temperature detectors					

Fan connection for DCS880 (H1 ... H4)

----- Terminals are located on top of the converter housing -----
 Converter housing ■

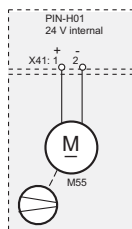

Configuration 1
H1

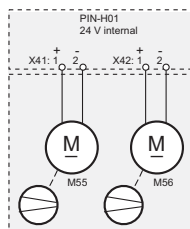

Configuration 2
H2 ... H3

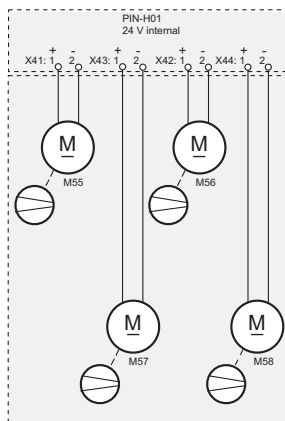

Configuration 3
H3

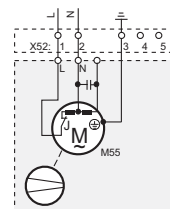

Configuration 4
H4

SA_880_011_DCS_FAN_c.ai

Fan data for DCS880 (H5 ... H8)

Fan	R2E250-RB		GR28C-2DK		GR35C-2DD	
Rated voltage [V _{AC}]	230; 1~		400 Δ 500 λ	460 Δ	400 / 460 ①/ 500 V ①	460 / 500 V ②
Tolerance [%]	±10		±10		±10	±10
Frequency [Hz]	50	60	50	60	50	60
Power consumption [W]	227	390	660 Δ 600 λ	1100 Δ	2100	3000
Current consumption [A]	1.1	1.7	1.4 Δ 0.8 λ	1.8 Δ	4.0 Δ	5.3 Δ
Blocking current [A]	3.1	3.1	at 400 V Δ 8.0 at 500 V λ 2.8	at 460 V Δ 8.0	at 400 V > 17	at 460 V > 15
Air flow [m ³ /h] at working point	800 1.0 A	850 1.6 A	1600 @ 1.2 A (400 V Δ) 1500 @ 0.7 A (500 V λ)	1700 @ 1.6 A (460 V Δ)	4000 @ 4 A (400 V)	4500 @ 5.3 A (400 V)
Max. ambient temperature [°C]	< 55		< 55			
Useful lifetime of grease	appr. 40,000 h/40°C		appr. 30,000 h/40°C			
Protection	internal		Temperature detector: U _N ≤ 230 V~; I _N ≤ 2.5 A~			

- ① The fan needs an input voltage of 400 V_{AC} at 50 Hz. For 460 V_{AC}/500 V_{AC} use autotransformer (T8).
- ② The fan needs an input voltage of 460 V_{AC} at 60 Hz. For 500 V_{AC} use autotransformer (T8).

Fan connection for DCS880 (H5 ... H8)

Converter housing

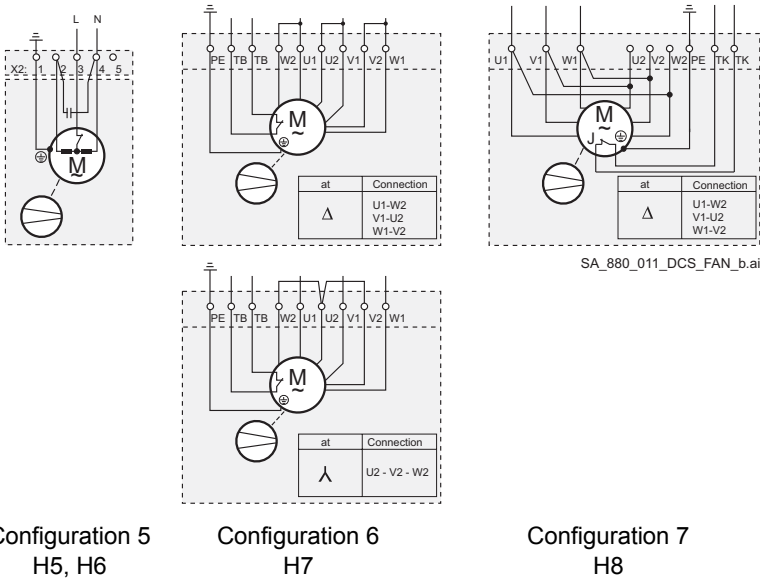

Monitoring the DCS880 power section

The power part of converters size H1 ... H6 is monitored by means of a galvanic isolated PTC thermistor. The PTC is installed on the heat sink in an isolated configuration. The PTC's resistance and protective effect correspond to the maximum temperature defined by the type code.

The air entry temperature at the power part of converters size H7 and H8 is monitored by means of a galvanic isolated PTC thermistor. The sensor measures the power part's radiated heat and any changes in the cooling air temperature and volume.

The PTC's resistance change is proportional to the temperature. It is read and evaluated in the drive's firmware. If the temperature increases above the preset value, then first a warning and - if the temperature continues to rise - a fault message is generated. The preset value must not be set more than 5 degrees above the permissible ambient temperature.

For converter size H7 and H8 the cooling air volume can only be detected indirectly. Thus, additionally a differential-pressure switch has been installed at the unit's housing. It is always located close to the power terminals.

The differential-pressure switch compares the pressure inside the drive with the normal air pressure. If the fan is switched on, the drive's door is closed, no covers have been removed and the pressure switch signals 'cooling conditions ok' it is possible to release the converter. There is no need to set a specific differential pressure (recommendation: use the center setting). The differential pressure switch should be connected to the converter fan acknowledge signal.

Implementing thermal overload and short-circuit protection

Protecting drive and input power cables in case of short-circuits

Protect drive and input cables using fuses as follows:

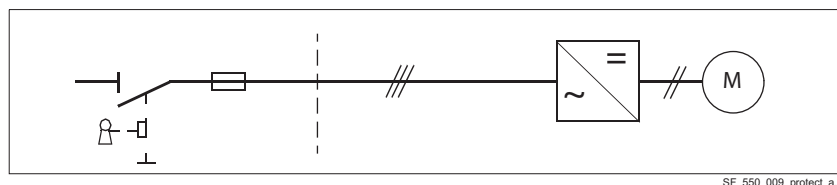

Size the fuses at the distribution board according to instructions given in chapter [Technical data](#). The fuses will protect the input cables in short-circuit situations, restrict drive damage and prevent damage to adjoining equipment in case of a short-circuit inside the drive.

Circuit breakers

The protective characteristics of circuit breakers depend on their type, construction and settings. There are also limitations regarding to the short-circuit capacity of the supply network. Your local ABB representative can help you in selecting the breaker type when the supply network characteristics are known.

WARNING

Due to the inherent operating principle and construction of circuit breakers, independent of the manufacturer, hot ionized gases can escape from the breaker enclosure in case of a short-circuit. To ensure safe use, pay special attention to the installation and placement of the breakers. Obey the manufacturer's instructions.

Protecting the motor and motor cable in case of short-circuits

The drive protects the motor cables and motor in a short-circuit situation when the motor cables are sized according to the nominal current of the drive. No additional protection devices are needed.

Protecting the drive and the input power and motor cables against thermal overload

The drive protects itself, its mains- and the motor cables against thermal overload when the cables are sized according to the nominal current of the drive. No additional thermal protection devices are needed.

WARNING

If the drive is connected to multiple motors, use a separate circuit breaker or fuses for protecting each motor cable and motor against overload. The drive overload protection is set to the total motor load. It may not trip due to an overload in one motor circuit only.

Protecting the motor against thermal overload

According to regulations, the motor must be protected against thermal overload and the current must be switched off when overload is detected. The drive includes a motor thermal protection function that protects the motor and switches off the current when necessary. Depending on a drive parameter value, the function either monitors a calculated temperature value (based on a motor thermal model) or an actual temperature indication given by motor temperature sensors. The user can tune the thermal model further by feeding in additional motor and load data.

The most common temperature sensors are:

- Motor sizes IEC180 ... 225: Thermal switch, e.g. klixon.
- Motor sizes IEC200 ... 250 and larger: PTC or Pt100.

See the [DCS880 Firmware Manual](#) for more information on the motor thermal protection, and the connection and use of the temperature sensors.

Protecting the drive against ground faults

The drive is not equipped with an internal ground fault protective function to protect the unit against ground faults in the motor and motor cables.

Residual current device compatibility

The drive is suitable to be used with residual current devices of Type B.





Note:

The EMC filter in front of the drive includes capacitors connected between the main circuit and the frame. These capacitors and long motor cables increase the ground leakage current and may cause fault current circuit breakers to function.

Cross-sectional areas - Tightening torques

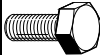
Recommended cross-sectional area to **DINVDE 0276-1000** and **DINVDE 0100-540 (PE)** trefoil arrangement, up to 50°C ambient temperature. The necessary wire torque at 60°C wire temperature is the same as recommended in the following table.

Armature:

Converter type	C1, D1		U1, V1, W1		PE			
	I_{DC} [A-]	1  [mm ²]	(2.)  [mm ²]	I_V [A~]				 [mm ²]
DCS880-S0B-0025-0d	25	1 x 6	-	21	1 x 4	1 x 10	1 x M6	6
DCS880-S0B-0050-0d	50	1 x 10	-	41	1 x 6	1 x 10	1 x M6	6
DCS880-S0B-0075-0d	75	1 x 25	-	61	1 x 25	1 x 16	1 x M6	6
DCS880-S0B-0100-0d	100	1 x 25	-	82	1 x 25	1 x 16	1 x M6	6
DCS880-S0B-0150-0d	150	1 x 35	-	114	1 x 35	1 x 16	1 x M10	25
DCS880-S0B-0200-0d	200	2 x 35	1 x 95	163	2 x 25	1 x 25	1 x M10	25
DCS880-S0B-0250-0d	250	2 x 35	1 x 95	204	2 x 25	1 x 25	1 x M10	25
DCS880-S0B-0300-0d	300	2 x 70	1 x 95	220	2 x 50	1 x 50	1 x M10	25
DCS880-S0B-0320-0d	320	2 x 70	1 x 95	220	2 x 50	1 x 50	1 x M10	25
DCS880-S0B-0350-0d	350	2 x 70	-	286	2 x 50	1 x 50	1 x M10	25
DCS880-S0B-0450-0d	450	2 x 95	-	367	2 x 95	1 x 95	1 x M10	25
DCS880-S0B-0520-0d	520	2 x 95	-	424	2 x 95	1 x 95	1 x M10	25
DCS880-S0B-0650-0d	650	2 x 120	-	555	2 x 120	1 x 120	1 x M12	50
DCS880-S0B-0680-0d	680	2 x 120	-	555	2 x 120	1 x 120	1 x M12	50
DCS880-S0B-0820-0d	820	2 x 150	-	669	2 x 120	1 x 120	1 x M12	50
DCS880-S0B-0900-06/07	900	4 x 95	3 x 150	734	4 x 70	1 x 150	2 x M12	50
DCS880-S0B-1000-0d	1000	2 x 185	-	816	2 x 150	1 x 150	1 x M12	50
DCS880-S0B-1190-0d	1190	4 x 120	-	971	4 x 95	2 x 95	2 x M12	50
DCS880-S0B-1200-0d	1200	4 x 120	-	979	4 x 95	2 x 95	2 x M12	50
DCS880-S0B-1500-0d	1500	4 x 185	-	1224	4 x 150	2 x 150	2 x M12	50
DCS880-S0B-2000-0d	2000	8 x 120	6 x 185	1632	4 x 240	2 x 240	2 x M12	50
DCS880-S0B-1900-0d	1900	8 x 120	6 x 185	1550	4 x 240	2 x 240	4 x M12	50
DCS880-S0B-2050-dd	2050	8 x 120	6 x 185	1673	6 x 120	3 x 120	4 x M12	50
DCS880-S0B-2500-0d	2500	7 x 185	-	2040	8 x 120	4 x 120	4 x M12	50
DCS880-S0B-2600-dd	2600	7 x 185	-	2122	8 x 120	4 x 120	4 x M12	50
DCS880-S0B-3000-0d	3000	8 x 185	-	2448	7 x 185	4 x 185	4 x M12	50
DCS880-S0B-3300-dd	3300	8 x 185	-	2693	7 x 185	4 x 185	4 x M12	50
DCS880-S0B-4000-dd	4000	7 x 300	-	3264	8 x 240	4 x 240	4 x M12	50
DCS880-S0B-4800-0d ①	4800	8 x 300	-	3876	6 x 300	3 x 300	4 x M12	50
DCS880-S0B-5200-0d ①	5200	8 x 300	-	4202	6 x 300	3 x 300	4 x M12	50

① Reduced ambient temperature 40°C.

You will find instructions on how to calculate the PE conductor's cross-sectional area in VDE 0100 or in equivalent national standards. We would remind you that power converters may have a current-limiting effect.

Excitation:

Size	H1	H1	H2	H3, H5, H6	H4	DCF803-0035
DC output current	6 A	12 A	18 A	25 A	30 A	35 A
max. cross sectional area	6 mm ² / AWG 10	6 mm ² / AWG 10	6 mm ² / AWG 10	6 mm ² / AWG 10	6 mm ² / AWG 10	6 mm ² / AWG 10
min. cross sectional area	1 mm ² / AWG 16	2.5 mm ² / AWG 13	4 mm ² / AWG 11	6 mm ² / AWG 10	6 mm ² / AWG 10	6 mm ² / AWG 10
Tightening torque	1.5 ... 1.7 Nm					

Selecting the power cables

General rules

- Select the input power and motor cables according to local regulations.
- Select a cable capable of carrying the drive nominal current. See chapter [Current ratings](#).
- Select a cable rated for at least 60°C maximum permissible temperature of conductor in continuous use.
- The inductance and impedance of the PE conductor/cable (grounding wire) must be rated according to permissible touch voltage appearing under fault conditions (so that the fault point voltage will not rise excessively when a ground fault occurs).
- A 600 V_{AC} cable is accepted for up to 500 V_{AC}.
- A 750 V_{AC} cable is accepted for up to 600 V_{AC}.
- For 690 V_{AC} rated equipment, the rated voltage between the conductors (L1, L2, L3) of the cable should be at least 1 kV.
- For mains voltages exceeding 690 V_{AC} and DC voltages exceeding 850 V_{DC} select power cables which comply with local regulations.

It is recommended to select following cables:

- UL: 2 kV voltage class.
- EN: Rated voltage conductor to earth 1000 V_{AC}/1500 V_{DC} and rated voltage conductor to conductor 1600 V_{AC}/3000 V_{DC}.

- The protective conductor must always have an adequate conductivity.

Unless local wiring regulations state otherwise, the cross-sectional area of the protective conductor must agree with the conditions that require automatic disconnection of the supply required in 411.3.2. of IEC 60364-4-41:2005 and be capable of withstanding the prospective fault current during the disconnection time of the protective device. The cross-sectional area of the protective conductor can either be selected from the table below or calculated according to 543.1 of IEC 60364-5-54.

The table below shows the minimum cross-sectional area related to the phase conductor size according to IEC 61800-5-1 when the phase conductor and the protective conductor are made of the same metal. If this is not so, the cross-sectional area of the protective earthing conductor shall be determined in a manner which produces a conductance equivalent to that which results from the application of this table.

Cross-sectional area of the phase conductors S (mm ²)	Minimum cross-sectional area of the corresponding protective conductor Sp (mm ²)
S ≤ 16	S
16 < S ≤ 35	16
35 < S	S/2

Additional US requirements

Use type MC continuous corrugated aluminum armor cable with symmetrical grounds or shielded power cable for the motor cables if metallic conduit is not used. For the North American market, 600 V_{AC} cable is accepted for up to 500 V_{AC}. 1000 V_{AC} cable is required above 500 V_{AC} (below 600 V_{AC}). For drives rated over 100 amperes, the power cables must be rated for 75°C (167°F)

Conduit

Couple separate parts of a conduit together. Bridge the joints with a ground conductor bonded to the conduit on each side of the joint. Also bond the conduits to the drive enclosure and motor frame. Use separate conduits for input power, motor, brake resistor and control wiring. When a conduit is employed, type MC continuous corrugated aluminum armor cable or shielded cable is not required. A dedicated ground cable is always required.

Note:

Do not run motor wiring from more than one drive in the same conduit.

Armored cable/shielded power cable

Six conductor (3 phases and 3 ground) type MC continuous corrugated aluminum armor cable with symmetrical grounds is available from the following suppliers (trade names in parentheses):

- Anixter Wire & Cable (Philsheath).
- BICC General Corp (Philsheath).
- Rockbestos Co. (Gardex).
- Oaknite (CLX).

Shielded power cables are available from Belden, LAPPKABEL (ÖLFLEX) and Pirelli.

Selecting the control cables

Shielding

All control cables must be shielded.

Use a double-shielded twisted pair cable (figure A below) for analog signals. This type of cable is also recommended for the pulse encoder signals. Employ one individually shielded pair for each signal. Do not use common return for different analog signals.

A double-shielded twisted pair cable (figure A below) is the best alternative for low-voltage digital signals but a single-shielded twisted pair cable (figure B below) is also acceptable.

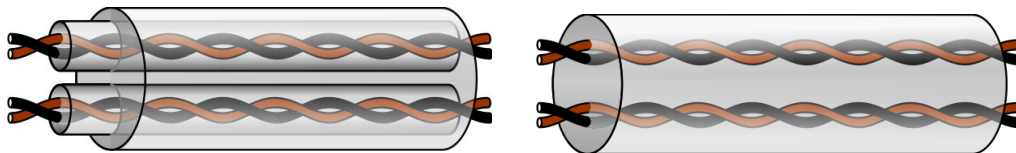

A: Double-shielded twisted pair cable.

B: Single-shielded twisted multi pair cable

The pairs should be twisted as close to the terminals as possible.

Signals in separate cables

Run analog and digital signals in separate, shielded cables. Never mix 24 V_{DC} and 115/230 V_{AC} signals in the same cable.

Signals allowed to be run in the same cable

Relay-controlled signals, providing their voltage does not exceed 48 V, can be run in the same cables as digital input signals. The relay-controlled signals should be run as twisted pairs too.

Relay cable type

The cable type with braided metallic screen (for example ÖLFLEX by LAPPKABEL, Germany) has been tested and approved by ABB.

Control Panel cable length and type

In remote use, the cable connecting the control panel to the drive must not exceed three meters (10 ft).

Cable type: Shielded CAT 5e or better Ethernet patch cable with RJ-45 ends.

Connection of a motor temperature sensor to the drive I/O



WARNING

IEC 60664 requires double or reinforced insulation between live parts and the surface of accessible parts of electrical equipment which are either nonconductive or conductive but not connected to the protective earth.

To fulfill this requirement, the connection of a thermistor (or other similar components) to the inputs of the drive can be implemented by 3 alternate ways:

- There is double or reinforced insulation between the thermistor and live parts of the motor.
- Circuits connected to all digital and analogue inputs of the drive are protected against contact and insulated with basic insulation (the same voltage level as the drive main circuit) from other low voltage circuits.
- An external thermistor relay is used. Rate the insulation of the relay for the same voltage level as the main circuit of the drive.

Also see section Fault Tracing / Motor Protection in [DCS880 Firmware manual](#).

Electrical installation

Chapter overview



This chapter describes the electrical installation procedure of the DCS880.

WARNING

A qualified electrician may only carry out the work described in this chapter. Follow the [Safety instructions](#) on the first pages of this manual. Ignoring the safety instructions can cause injury or death.

Make sure that the drive is disconnected from the mains (input power) during installation. If the drive was already connected to the mains, wait for 5 min. after disconnecting mains power.

Further information is available in the [Technical guide](#).

Checking the insulation of the drive



Every converter has been tested for insulation between the main circuit and the chassis (2500 V rms 50 Hz for 1 second) at the factory. Therefore, do not make any voltage tolerance or insulation resistance tests (e.g. hi-pot or megger) on any part of the converter. Check the insulation of the drive as follows.

WARNING

Check the insulation before connecting the drive to the mains. Make sure that the drive is disconnected from the mains (input power).

1. Check that the motor cables are disconnected from the converter output terminals C1, D1, F+ and F-.
2. Measure the insulation resistances of the motor cable and the motor between each circuit (C1, D1) / (F+, F-) and the Protective Earth (PE) by using a measuring voltage of 1 kV DC. The insulation resistance must be higher than 1 MOhm.

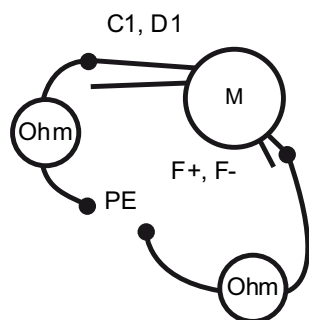

SB_DCS_001_elektr-inst_a.ai

IT (ungrounded) systems

Don't use EMC filters in IT systems.

The screen winding of existing dedicated transformers must be grounded.

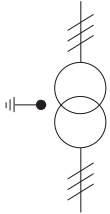

For installation without low voltage switch (e.g. contactor, air-circuit-breaker) use an overvoltage protection on the secondary side of the mains transformer.

The voltage shift of the isolated supply must not be larger than the voltage shift in case on an earth fault.

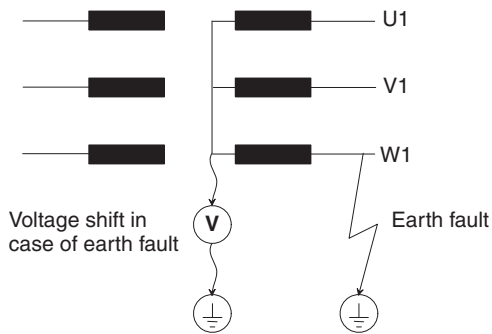

SA_550_003_netzanschl_a.ai

Supply voltage

Check supply voltages of:

Auxiliary voltage	XAUX (X99) on SDCS-PIN-H01 / SDCS-POW-H01
Cooling fan	Terminals
Mains voltage for field circuit	U1, V1, W1 (if used)
Mains voltage for armature circuit	U1, V1, W1

Connecting the power cables

Check:

Grounding and screening of power cables see manual [Technical guide](#).

Cross sectional areas and tightening torques of power cable see chapter [Cross-sectional areas - Tightening torques](#).

Location F-type adapters and interfaces

Connect the signal cables as described below. Tighten the screws to secure the extension modules and the memory unit.

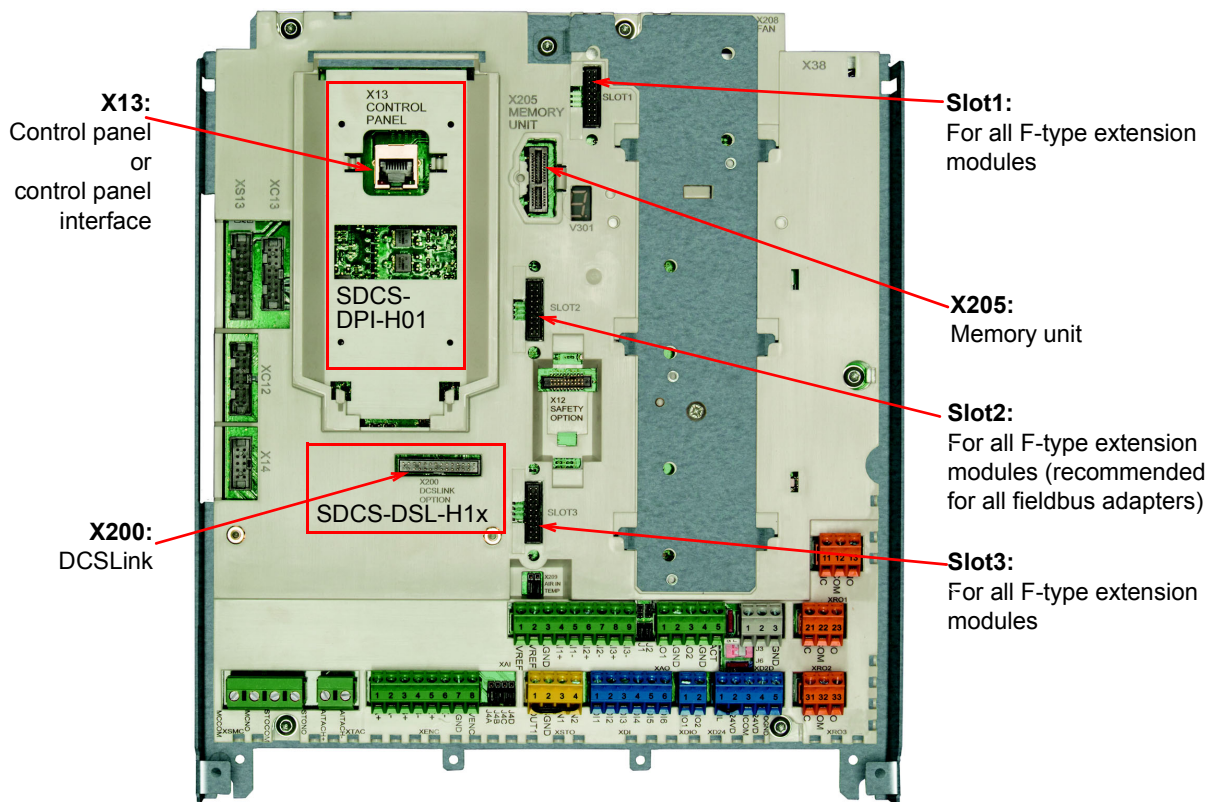

Fieldbus adapters



I/O extension modules



FEA-03 I/O extension adapter configuration

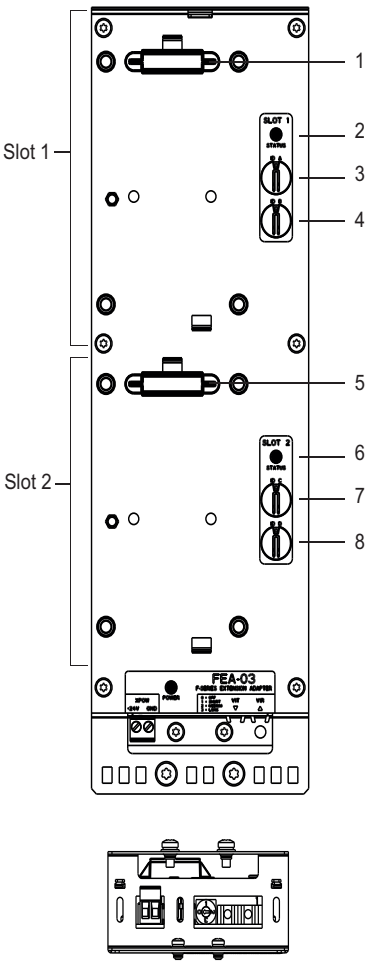
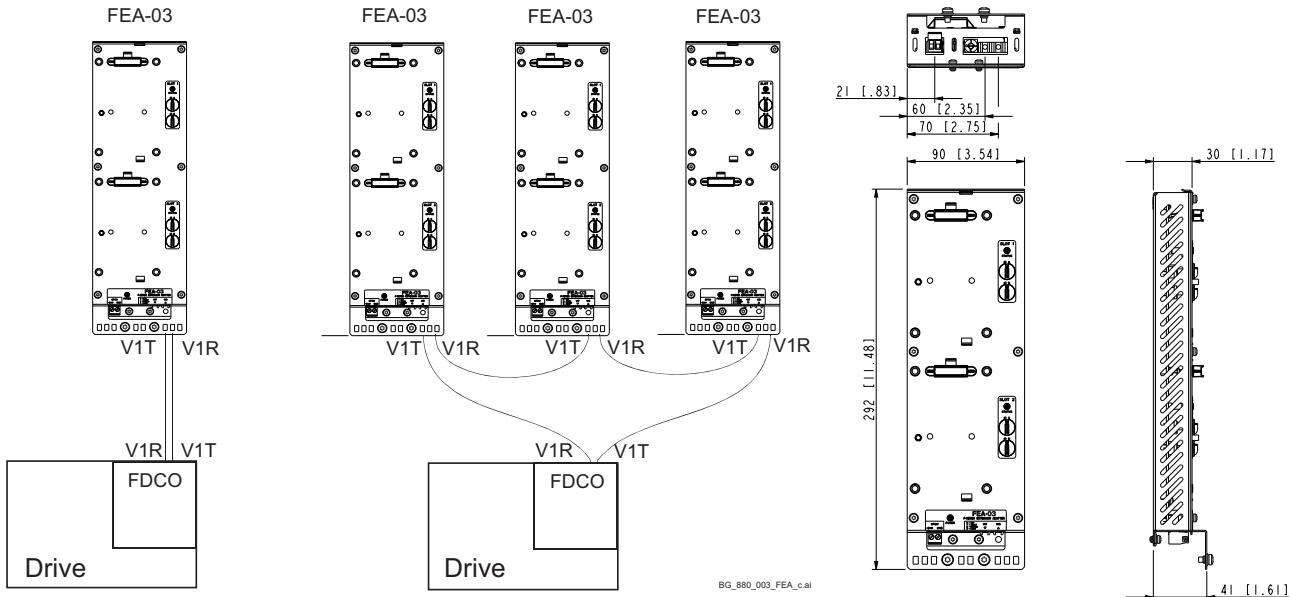



Item	Description
1	Module connector 1
2	Status LED for Slot 1
3	Node address switch A (digit 10)
4	Node address switch B (digit 0)
5	Module connector 2
6	Status LED for Slot 2
7	Node address switch C (digit 10)
8	Node address switch D (digit 0)
9	Power supply connector (XPOW:+24 V/GND, 100 mA plus current for option modules)
10	Transmitter V1T and receiver V1R
11	Selector for V1T and V1R

Pulse encoder connection

OnBoard encoder interface (XENC on SDCS-CON-H01)

On the SDCS-CON-H01 it is possible to select the supply voltage using jumper J4D.

Hardware configuration		
Encoder supply	SDCS-CON-H01	J4D
5 V, default	no sense	
24 V	no sense	

The wiring is shown in the figure below.

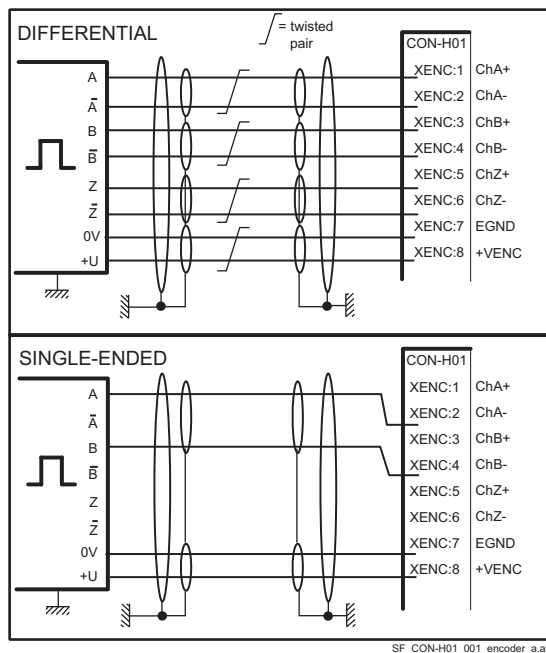

Commissioning hint:

If the drive's measured direction of rotation is wrong or does not correspond to the measured EMF speed, fault 7301 Motor speed feedback may appear during start-up.

If necessary correct it by exchanging the field connections F1 and F2 or exchange tracks A+ and A-.

For single-ended encoders tracks A- and B- must be exchanged.

94.16 OnBoard encoder position should look like this:

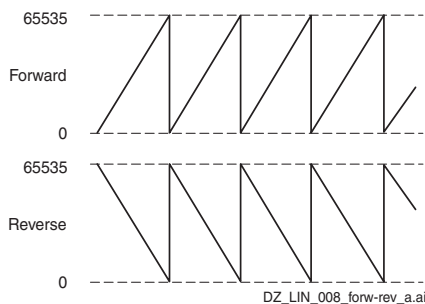

Pulse encoder connection principles

Two different encoder connections are available.

1. Differential connection; only pulse encoders generating voltage signals can be used.
2. Single-ended (push pull) connection; only pulse encoders generating voltage signals can be used.

Pulse encoder connection principles:

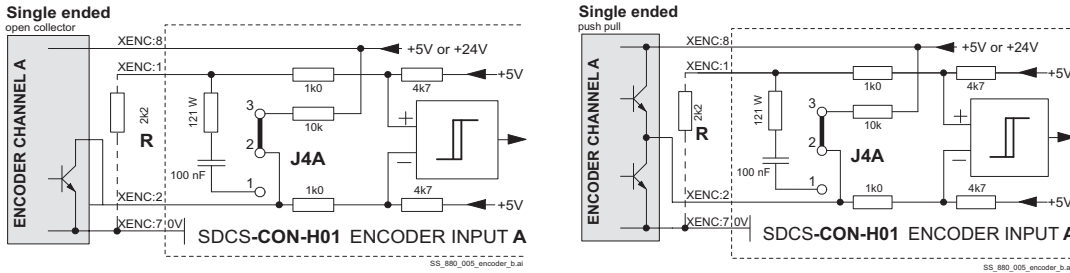

In case of single ended encoders jumpers J4A ... J4C have to be set to a neutral position according to the table below.

To get a threshold lower than 5 V each terminal XENC:1, 3 and 5 must be connected via a resistor R to GND.

Jumper settings for single ended encoders connected to SDCS-CON-H01

Jumper	SDCS-CON-H01				
J4A	2 - 3	<input type="checkbox"/>	2 - 3	<input type="checkbox"/>	Single ended
J4B	5 - 6	<input checked="" type="checkbox"/>	5 - 6	<input checked="" type="checkbox"/>	
J4C	8 - 9	<input checked="" type="checkbox"/>	8 - 9	<input checked="" type="checkbox"/>	
J4D	5 V: 10 - 11	<input type="checkbox"/>	24 V: 11 - 12	<input checked="" type="checkbox"/>	Voltage source

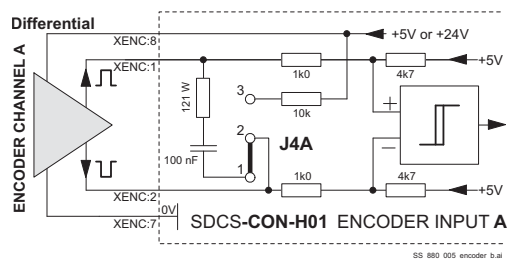

Jumper settings for differential encoders connected to SDCS-CON-H01

Jumper	SDCS-CON-H01				
J4A	1 - 2		1 - 2		Differential
J4B	4 - 5		4 - 5		
J4C	7 - 8		7 - 8		
J4D	5 V: 10 - 11		24 V: 11 - 12		Voltage source

The maximum distance between pulse encoder and SDCS-CON-H01 depends on the voltage drop of the connecting lines and on the output and input configuration of the used components. Use cables according to the table below. Use twisted pair cables with pair shielding plus overall shielding.

Cable length	Parallel wires for power source & GND	Cable used
0 ... 50 m	1 x 0.25 mm ²	12 x 0.25 mm ²
50 ... 100 m	2 x 0.25 mm ²	12 x 0.25 mm ²
100 ... 150 m	3 x 0.25 mm ²	14 x 0.25 mm ²

Cable length	Parallel wires for power source & GND	Cable used
0 ... 164 ft	1 x 24 AWG	12 x 24 AWG
164 ... 328 ft	2 x 24 AWG	12 x 24 AWG
328 ... 492 ft	3 x 24 AWG	14 x 24 AWG

Connecting the signal and control cables

Used screened cables for digital signals, which are longer than 3 m and for all analog signals. Connect each screen at both ends by metal clamps or comparable means directly on clean metal surfaces, if both earthing points belong to the same earth line. Otherwise, connect a capacitor to earth on one end. In the converter cabinet this kind of connection must be made directly on the sheet metal close to the terminals and if the cable comes from outside also on the PE bar. At the other end of the cable, connect the screen well with the housing of the signal emitter or receiver.

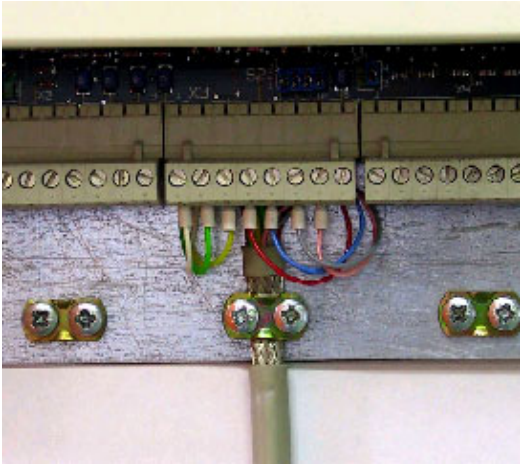

Connection of cable screens with metal clamps to the metal surface of the electronic tray.

Size H7, H8 screen connection

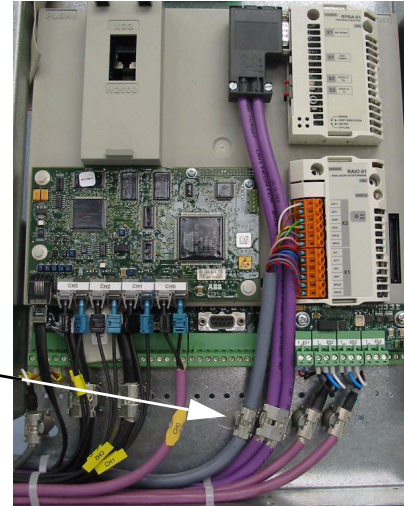

Routing the cables

Run the motor cable away from other cable routes. Motor cables of several drives can be run in parallel installed next to each other. Motor cables, input power cables and control cables should be installed on separate trays.

Avoid long parallel runs of motor cables with other cables to decrease electromagnetic interference caused by the rapid changes in the drive output voltage.

Where control cables must cross power cables, ensure they are arranged at an angle as close to 90 degrees as possible. Do not run spare cables through the drive or cabinet.

The cable trays must have good electrical bonding to each other and to the grounding electrodes.

Aluminum tray systems can be used to improve local equalizing of potential.

The following diagrams show the proper routing of cables.

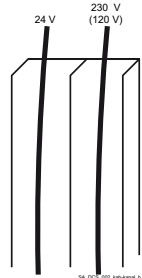
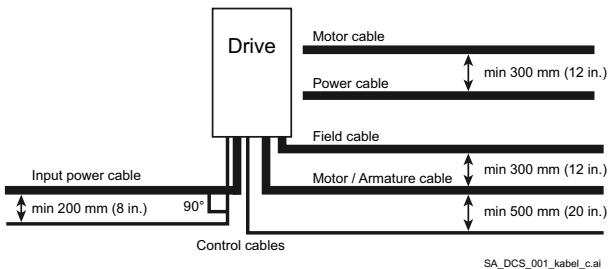

Route 24 V_{DC} and 120/230 V_{AC} control cables in separate ducts inside the cabinet.



Not allowed unless the 24 V_{DC} cable is insulated for 120/230 V_{AC} or insulated with an insulation sleeving for 120/230 V_{AC}.

Continuous motor cable shield or enclosure for equipment on the motor cable

To minimize the emission level when safety switches, contactors, connection boxes or similar equipment are installed on the motor cable between the drive and the motor:

- European Union: Install the equipment in a metal enclosure with 360 degree grounding for the shields of both the incoming and outgoing cable, or connect the shields of the cables otherwise together.
- US: Install the equipment in a metal enclosure in a way that the conduit or motor cable shielding runs consistently without breaks from the drive to the motor.

DCSLink wiring

The DCSLink is a 500 kBaud serial communication between drives and drives to field exciters.

It is based on CAN hardware and using twisted cables.

The topology is a bus system.

Switched OFF nodes can remain in the bus and do not disturb the serial communication.

The function of the interface is predefined:

1. Communication to field exciter types DCF803, DCF804 and large field exciters using standard DCS880 modules.
2. Communication for 12-pulse operation, DCS880 to DCS880.

Cabling

Every bus device requires its own individual node number.

Only two physical ends are allowed for the bus system.

The termination resistance of 120 Ohm is selected for typical twisted pair cables. The cables must be terminated at both ends. This is done using jumpers or switches inside the drives or field exciter.

Maximum total cable length is 100 m.

Preferred cable type: DEVICENET
 Supplier: Helu Kabel, Germany; type 81910PUR
 Belden, USA; type 3084A

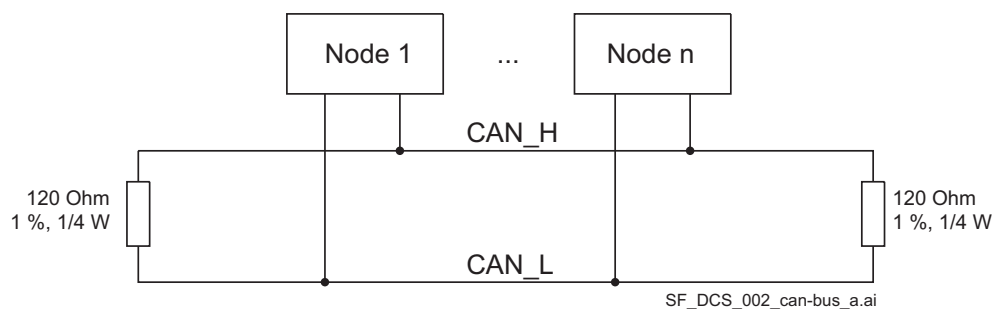

Example of two DCS880 converters, one as armature converter, the other one as large field exciter.

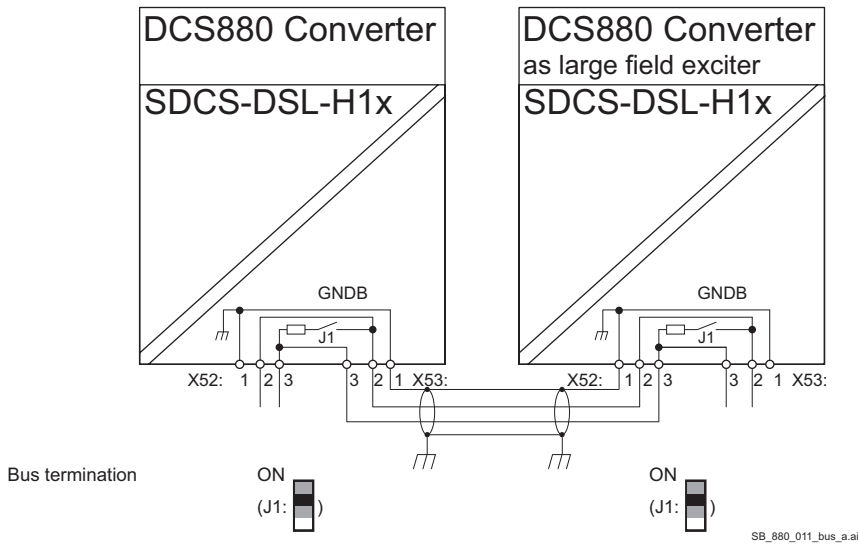

Example of two DCS880 H5, H6 converters with FEX-425-Int internal field supply.

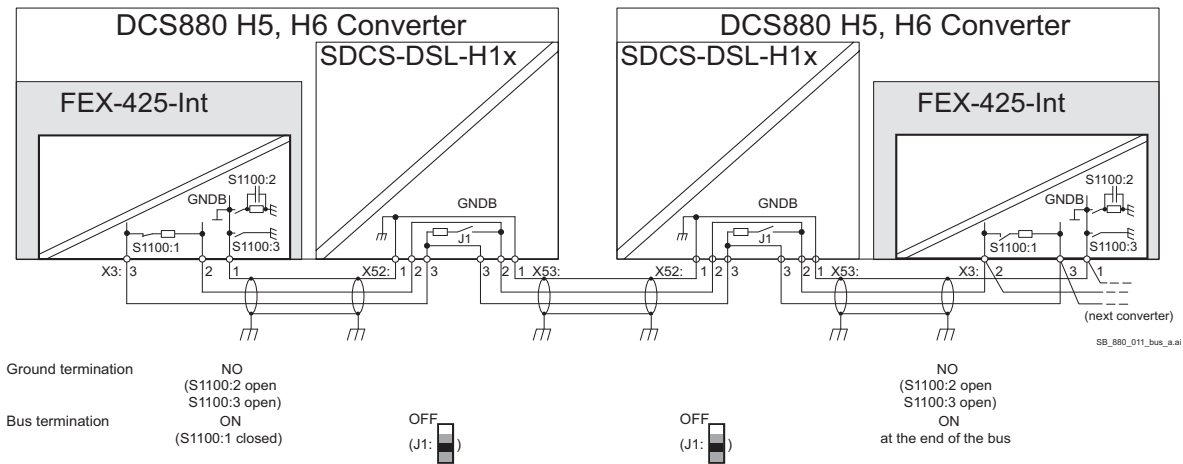

The connection of isolated GNDB between two or more serial communication interfaces is optional. It is recommended to connect GNDB if the supply voltage is above 690 V and the cabling is made from cubicle to cubicle.

Example of one DCS880 converter plus external field supply.

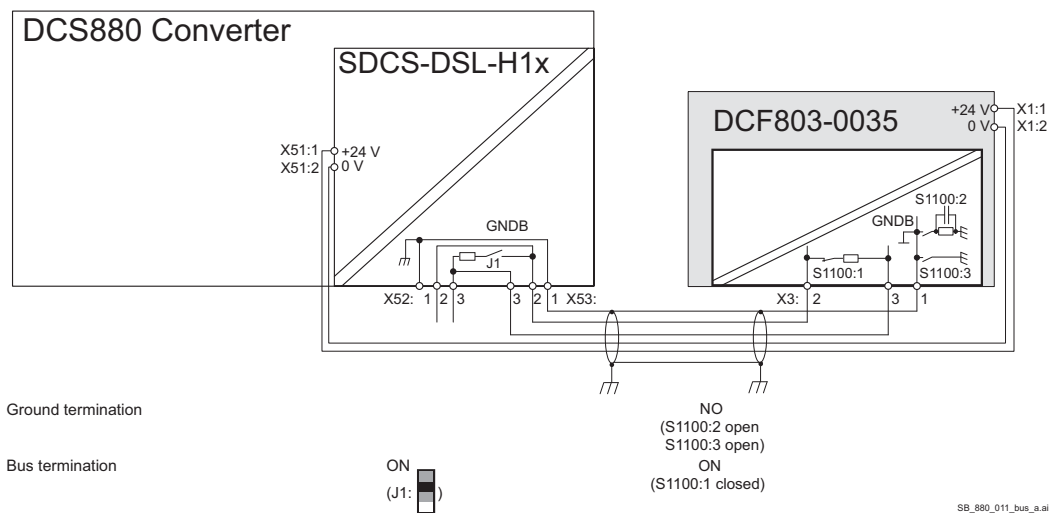

Cable length

The cable length influences the maximum baudrate.

Baudrate	max. cable length
50 k	500 m
125 k	500 m
250 k	250 m
500 k	100 m
800 k	50 m
888 k	35 m
1000 k	25 m

default and recommended setting

The bus is designed for a total cable length up to 100 meters. Larger distances on request.

Connecting a control unit at H7 and H8 power units

During installation the control unit needs to be connected with the power unit using fiber optic cables. For a standard drive connect the fiber optic cables from the SDCS-DSL-H1x (control unit) to the SDCS-OPL-H01(power unit).

The mains contactor is controlled via XSMC (X96) on the SDCS-OPL-H01 located in the power unit. The current measurement using a scope is possible via X4.

Connecting according to the drawing below:

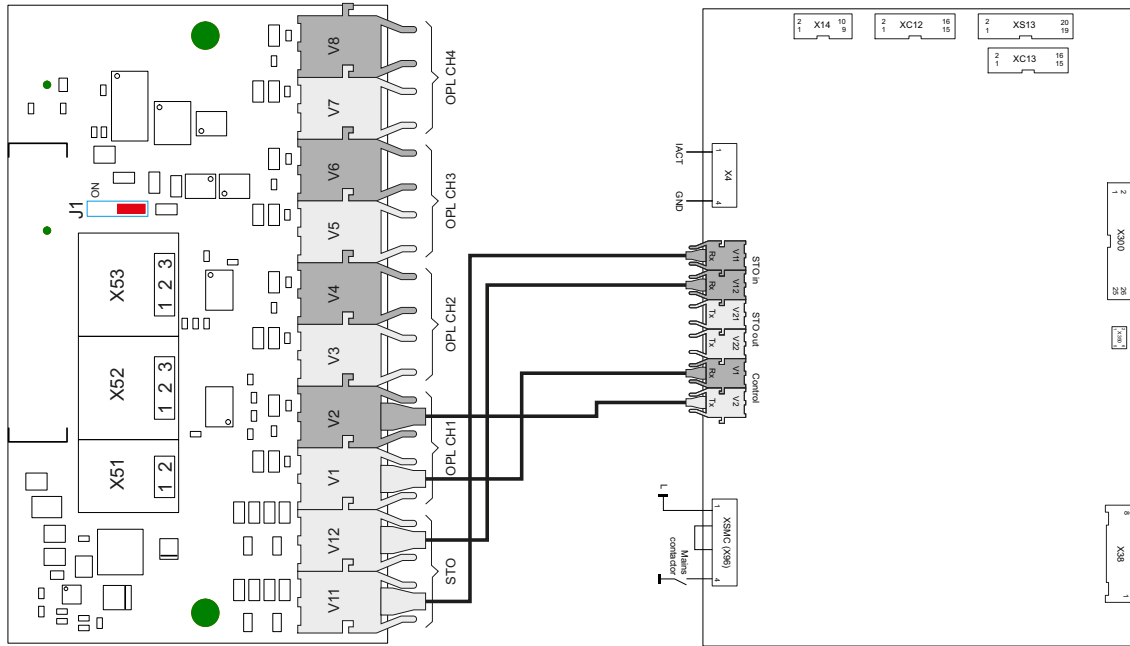

BL_DSLH1x+OPL_001_b.ai

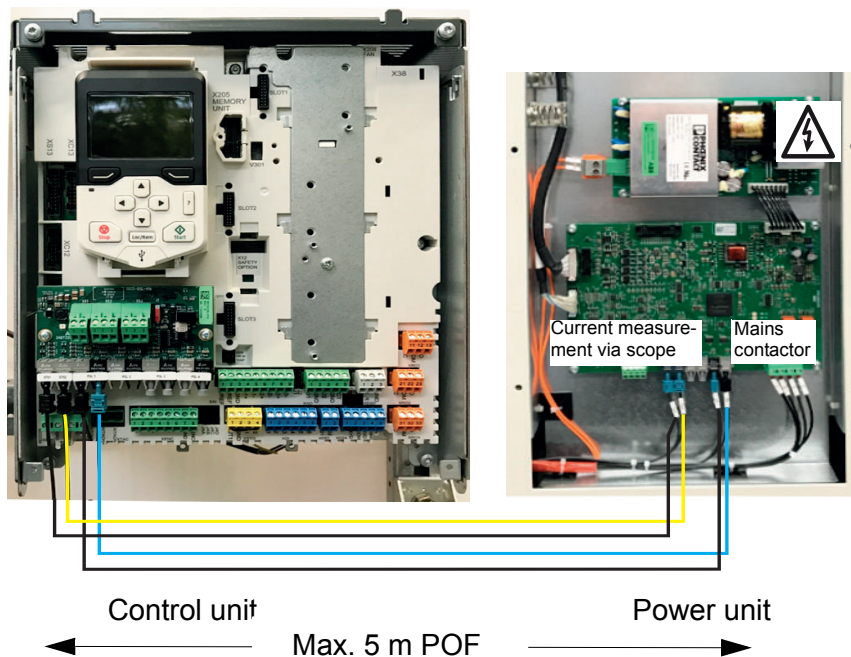

Installation checklist

Check the mechanical and electrical installation of the drive before start-up. Go through the checklist below together with another person. Read the [Safety instructions](#) on the first pages of this manual before you work on the unit.

MECHANICAL INSTALLATION

- The ambient operating conditions are allowed (see [Environmental Conditions](#), [Current ratings](#))
- The unit is mounted properly on a vertical non-flammable wall (see [Mechanical installation](#))
- The cooling air will flow freely (see [Cabinet installation](#), [Mounting the converter module inside an enclosure](#))
- The motor and the driven equipment are ready for start
- All screen terminals are checked for tightness (see [Connecting the signal and control cables](#))
- All cable connections are seated properly (see [Connecting the signal and control cables](#))

ELECTRICAL INSTALLATION (see [Planning the electrical installation](#), [Electrical installation](#))

- The converter modules are grounded properly
- The mains voltage matches the converter module's nominal input voltage
- The mains (input power) connections at U1, V1 and W1 (L1, L2 and L3) and their tightening torques are OK
- The appropriate mains fuses and disconnecter are installed
- The drive connections at C1, D1 and F+, F- and their tightening torques are OK
- Motor cable routing (armature and excitation) is OK
- Check that the screens are properly installed at the motor and the drive cabinet
- The motor connections L+, L-, F+ and F- and their tightening torques are OK
- The control connections are OK
- If a pulse encoder is used, check the encoder cables and correct direction of rotation
- PTC, klixon cables: Check that the connections are appropriate for the type of sensor used in the motor
- Check the Safe Torque Off (STO) circuit for proper function
- Check the prevention of unexpected start-up (on inhibit, coast stop) circuit for proper function
- Proper function of E-stop circuit and relay
- Cooling fan power wiring connected
- The external control connections inside the drive are OK
- There are no tools, foreign objects or drill cuttings inside the drive
- Converter, motor connection box and other covers are in place

Maintenance

Chapter overview

This chapter contains preventive maintenance instructions. For more information see [DCS880 Service Manual](#).

Safety



WARNING

Read the [Safety instructions](#) on the first pages of this manual before performing any maintenance on the equipment. Ignoring the safety instructions can cause injury or death.

Technical data

Chapter overview

The technical data contain the technical specifications of the converter, e.g. the ratings, sizes and technical requirements, provisions for fulfilling the requirements for CE and other markings and warranty policy.

Environmental Conditions

System connections

Voltage, 3-phase:	100 ... 1000 V acc. to IEC 60038 100 ... 690 V acc. to UL508c
Voltage deviation:	IEC: -10% +15% continuous; ±20% short-time (0.5 to 30 cycles) UL: ±10 % continuous; ±15 % short-time (0.5 to 30 cycles)
Rated frequency:	50 Hz or 60 Hz
Static frequency deviation:	50 Hz ± 2 %; 60 Hz ± 2 %
Dynamic: frequency range:	50 Hz ± 5 Hz; 60 Hz ± 5 Hz
df/dt:	17 % / s

Please note: Special consideration must be taken for voltage deviation in regenerative mode.

Degree of protection

Converter module and options (line chokes, fuses, field exciters, etc.):	IEC: IP 00; acc. to IEC/EN 60529 UL: open type acc. to UL 508c
Overvoltage category (all inputs):	III acc. to IEC 60664-1
Protective class:	I acc. to IEC 61800-5-1

Paint finish

Converter module:	Body RAL 7012 Cover RAL 9017 & RAL 9002
-------------------	--

Environmental limit values

Permissible cooling air temp.	
- at converter module air inlet:	0 ... +55°C
with rated DC current:	0 ... +40°C
with different DC current:	+30 ... +55°C
- Options:	0 ... +40°C
Relative humidity (at 5...+40°C):	5 ... 95 %, no condensation
Relative humidity (at 0...+5°C):	5 ... 50 %, no condensation
Change of the ambient temp.:	< 0.5°C / minute
Storage temperature:	-40 ... +55°C
Transport temperature:	-40 ... +70°C
Pollution degree (IEC 60664-1, IEC 60439-1):	2

Site elevation

< 1000 m above M.S.L.:	100 %, without current reduction
> 1000 m above M.S.L.:	with current reduction

Permissible supply systems:	IT, TN, TT (neutral earthed) IT (corner earthed) TT (corner earthed)
-----------------------------	--

Sound pressure level and vibration

Size	Sound pressure level L_p (1 m distance)		Vibration as module
	as module	enclosed conv.	
H1	55 dBA	68 dBA	3 mm, 2 - 9 Hz 1 g, 9 ... 200 Hz
H2	55 dBA	72 dBA	
H3	60 dBA	78 dBA	
H4	66 ... 70 dBA, depending on fan	77 dBA	
H5	75 dBA	77 dBA	0,3 mm, 2 - 9 Hz 0,1 g, 9 ... 200 Hz
H6	70 dBA	78 dBA	
H7	69 dBA	67 dBA	
H8	82 dBA	80 dBA	

North American Standards

In North America the system components fulfil the requirements of the table below.

Rated supply voltage	Standards	
	Converter module	Enclosed converter
to 990 V	UL 61800-5-1 Power Conversion Equipment CSA C 22.2 No. 274-13 Industrial Control Equipment, Industrial Products Available for converter modules including field exciter units. Types with UL mark: • see UL Listing www.ul.com / certificate no. E196914 • or on request	UL/CSA types: on request

Regulatory compliance

The converter module and enclosed converter components are designed for use in industrial environments. In EEA countries, the components fulfil the requirements of the EU directives, see table below:

European Union Directive	Manufacturer's Assurance	Harmonized Standards
		Converter module
Machinery Directive		
2006/42/EC	Declaration of Incorporation	[IEC 60204-1]
Low Voltage Directive		
2014/35/EU	Declaration of Conformity	EN 61800-1 [IEC 61800-1] EN 60204-1 [IEC 60204-1] EN 61800-5-1 [IEC 61800-5-1]
EMC Directive		
2014/30/EU	Declaration of Conformity (If all installation instructions concerning cable selection, cabling and EMC filters or dedicated transformer are followed.)	EN 61800-3 [IEC 61800-3] in accordance with 3ADW000032

Effect of the site elevation above sea level on the converter's load capacity

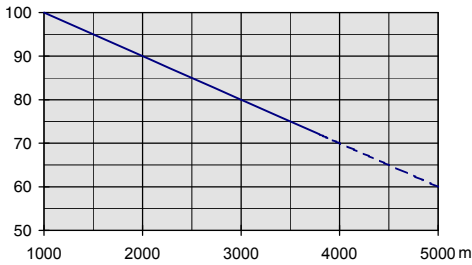

Current reduction to % of nominal converter current

Effect of the ambient temperature on the converter's load capacity

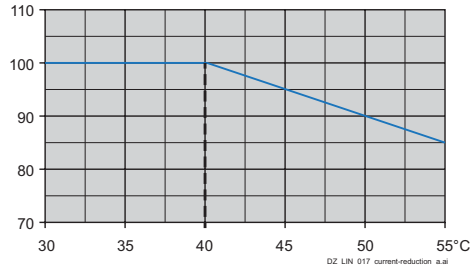

Current reduction to % of nominal converter current

Effect of site elevation and ambient temperature on the converter's load capacity

Ambient temperature	Site elevation in m above M.S.L.			
	≤ 1000 m	≤ 2000 m	≤ 3000 m	≤ 4000 m
30°C	100 %	100 %	90 %	80 %
35°C	100 %	95 %	85 %	75 %
40°C	100 %	90 %	80 %	
45°C	95 %	85 %		
50°C	90 %	80 %		
55°C	85 %			

Current reduction to % of nominal converter current

Current ratings - IEC regenerative converters (S02)

See the current ratings including several standard duty cycles for the DCS880 with 50 Hz and 60 Hz supplies below. The current ratings are based on an ambient temperature of maximum 40°C and an elevation of maximum 1000 m above mean sea level:

Unit type	I _{DC I} continuous	I _{DC II}		I _{DC III}		I _{DC IV}		Size	Internal field current
		100 % 15 min	150 % 60 s	100 % 15 min	150 % 120 s	100 % 15 min	200 % 10 s		
4-Q converters									
400 V / 500 V (IEC) / 525 V (UL)	[A]	[A]		[A]		[A]			
DCS880-S02-0025-04/05 ^①	25	22	33	21	31	20	40	H1	0.3 ... 6 A
DCS880-S02-0050-04/05 ^①	50	38	57	37	55	33	66		1 ... 12 A
DCS880-S02-0075-04/05 ^①	75	60	90	59	88	54	108		
DCS880-S02-0100-04/05 ^①	100	85	127	83	124	80	160	H2	1 ... 18 A
DCS880-S02-0150-04/05	150	114	171	110	165	100	200		
DCS880-S02-0200-04/05 ^①	200	145	217	140	210	115	230		
DCS880-S02-0250-04/05	250	185	277	180	270	165	330	H3	2 ... 25 A
DCS880-S02-0300-04/05	300	225	337	220	330	200	400		
DCS880-S02-0350-04/05 ^①	350	275	412	265	397	245	490		
DCS880-S02-0450-04/05 ^①	450	350	525	340	510	310	620	H4	2 ... 30 A
DCS880-S02-0520-04/05	520	400	600	380	570	350	700		
DCS880-S02-0680-04/05 ^①	680	525	787	510	765	475	950		
DCS880-S02-0820-04/05	820	630	945	610	915	565	1130	H5	25 A ^③ +S164
DCS880-S02-1000-04/05	1000	750	1125	725	1087	660	1320		
DCS880-S02-1190-04/05	1190 ^②	860	1290	835	1253	745	1490		
DCS880-S02-1200-04/05	1200	888	1332	872	1308	764	1528	H6	-
DCS880-S02-1500-04/05	1500	1200	1800	1156	1734	1104	2208		
DCS880-S02-2000-04/05	2000	1479	2219	1421	2132	1361	2722		
DCS880-S02-2050-05	2050	1550	2325	1480	2220	1450	2900	H7	-
DCS880-S02-2500-04/05	2500	2000	3000	1930	2895	1790	3580		
DCS880-S02-3000-04/05	3000	2330	3495	2250	3375	2080	4160		
DCS880-S02-3300-04/05	3300	2416	3624	2300	3450	2277	4554	H8	-
DCS880-S02-4000-04/05	4000	2977	4466	2855	4283	2795	5590		
DCS880-S02-5200-04/05	5200	3800	5700	3669	5504	3733	7466		
600 V / 690 V									
DCS880-S02-0320-06	320	256	384	246	369	235	470	H3	-
DCS880-S02-0650-06	650	514	771	508	762	462	924	H4	-
DCS880-S02-0900-06/07	900	684	1026	670	1005	594	1188	H6	25 A ^③ +S164
DCS880-S02-1500-06/07	1500	1200	1800	1104	1656	1104	2208		
DCS880-S02-2050-06/07	2050	1520	2280	1450	2175	1430	2860		
DCS880-S02-2500-06/07	2500	1940	2910	1870	2805	1740	3480	H7	-
DCS880-S02-3000-06/07	3000	2270	3405	2190	3285	2030	4060		
DCS880-S02-3300-06/07	3300	2416	3624	2300	3450	2277	4554		
DCS880-S02-4000-06/07	4000	3036	4554	2900	4350	2950	5900	H8	-
DCS880-S02-4800-06/07	4800	3734	5601	3608	5412	3700	7400		
800 V									
DCS880-S02-1900-08	1900	1500	2250	1430	2145	1400	2800	H7	-
DCS880-S02-2500-08	2500	1910	2865	1850	2775	1710	3420		
DCS880-S02-3000-08	3000	2250	3375	2160	3240	2000	4000		
DCS880-S02-3300-08	3300	2655	3983	2540	3810	2485	4970	H8	-
DCS880-S02-4000-08	4000	3036	4554	2889	4334	2933	5866		
DCS880-S02-4800-08	4800	3734	5601	3608	5412	3673	7346		
990 V									
DCS880-S02-2050-10	2050	1577	2366	1500	2250	1471	2942	H8	-
DCS880-S02-2600-10	2600	2000	3000	1900	2850	1922	3844		
DCS880-S02-3300-10	3300	2551	3827	2428	3642	2458	4916		
DCS880-S02-4000-10	4000	2975	4463	2878	4317	2918	5836		
1190 V				Data on request					

① This unit type can be used as large field exciter. Do not forget the SDCS-DSL-H10 (+S521).

A 10 % current de-rating is strongly recommended.

② 1190 A_{DC} for 35°C and 1140 A_{DC} for 40°C ambient temperature.

③ As option.

Notes:

AC current $I_{AC} = 0.82 \cdot I_{DC}$.

The ratings apply at ambient temperature of 40°C (104°F). For lower temperatures the H6, H7, H8 ratings are higher (except I_{max}). Use DriveSize for detailed dimensioning in case the ambient temperature is below 40°C (104°F) or the drive is loaded cyclically.

Current ratings - IEC non regenerative converters (S01)

Unit type	$I_{DC I}$		$I_{DC II}$		$I_{DC III}$		$I_{DC IV}$		Size	Internal field current	
	continuous	100 % 15 min	150 % 60 s	100 % 15 min	150 % 120 s	100 % 15 min	200 % 10 s				
2-Q converters											
400 V / 500 V (IEC) / 525 V (UL)	[A]	[A]		[A]		[A]					
DCS880-S01-0020-04/05①	20	16	24	16	24	15	30	H1	0.3 ... 6 A		
DCS880-S01-0045-04/05①	45	36	54	35	52	31	62				
DCS880-S01-0065-04/05①	65	54	81	52	78	49	98				
DCS880-S01-0090-04/05①	90	76	114	74	111	73	146				
DCS880-S01-0135-04/05	135	105	157	100	150	93	186	H2	1 ... 18 A		
DCS880-S01-0180-04/05①	180	130	195	125	187	110	220				
DCS880-S01-0225-04/05	225	170	255	165	247	148	296				
DCS880-S01-0270-04/05	270	200	300	195	292	180	360				
DCS880-S01-0315-04/05①	315	240	360	235	352	215	430	H3	2 ... 25 A		
DCS880-S01-0405-04/05①	405	310	465	300	450	270	540				
DCS880-S01-0470-04/05	470	350	525	340	510	310	620				
DCS880-S01-0610-04/05①	610	455	682	435	652	425	850				
DCS880-S01-0740-04/05	740	570	855	540	810	525	1050	H4	2 ... 30 A		
DCS880-S01-0900-04/05	900	680	1020	650	975	615	1230				
DCS880-S01-1190-04/05	1190 ②	860	1290	835	1253	745	1490	H5	25 A ③ +S164		
DCS880-S01-1200-04/05	1200	888	1332	872	1308	764	1528				
DCS880-S01-1500-04/05	1500	1200	1800	1156	1734	1104	2208				
DCS880-S01-2000-04/05	2000	1479	2219	1421	2132	1361	2722				
DCS880-S01-2050-05	2050	1550	2325	1480	2220	1450	2900	H7	-		
DCS880-S01-2500-04/05	2500	1980	2970	1880	2820	1920	3840				
DCS880-S01-3000-04/05	3000	2350	3525	2220	3330	2280	4560	H8	-		
DCS880-S01-3300-04/05	3300	2416	3624	2300	3450	2277	4554				
DCS880-S01-4000-04/05	4000	2977	4466	2855	4283	2795	5590				
DCS880-S01-5200-04/05	5200	3800	5700	3669	5504	3733	7466				
600 V / 690 V											
DCS880-S01-0290-06	290	240	360	225	337	205	410	H3	-		
DCS880-S01-0590-06	590	470	705	472	708	434	868	H4	-		
DCS880-S01-0900-06/07	900	684	1026	670	1005	594	1188	H6	25 A ③ +S164		
DCS880-S01-1500-06/07	1500	1200	1800	1104	1656	1104	2208				
DCS880-S01-2000-06/07	2000	1479	2219	1421	2132	1361	2722				
DCS880-S01-2050-06/07	2050	1520	2280	1450	2175	1430	2860				
DCS880-S01-2500-06/07	2500	1940	2910	1840	2760	1880	3760	H7	-		
DCS880-S01-3000-06/07	3000	2530	3795	2410	3615	2430	4860				
DCS880-S01-3300-06/07	3300	2416	3624	2300	3450	2277	4554	H8	-		
DCS880-S01-4000-06/07	4000	3036	4554	2900	4350	2950	5900				
DCS880-S01-4800-06/07	4800	3734	5601	3608	5412	3700	7400				
800 V											
DCS880-S01-1900-08	1900	1500	2250	1430	2145	1400	2800	H7	-		
DCS880-S01-2500-08	2500	1920	2880	1820	2730	1860	3720				
DCS880-S01-3000-08	3000	2500	3750	2400	3600	2400	4800				
DCS880-S01-3300-08	3300	2655	3983	2540	3810	2485	4970				
DCS880-S01-4000-08	4000	3036	4554	2889	4334	2933	5866	H8	-		
DCS880-S01-4800-08	4800	3734	5601	3608	5412	3673	7346				
990 V											
DCS880-S01-2050-10	2050	1577	2366	1500	2250	1471	2942	H8	-		
DCS880-S01-2600-10	2600	2000	3000	1900	2850	1922	3844				
DCS880-S01-3300-10	3300	2551	3827	2428	3642	2458	4916				
DCS880-S01-4000-10	4000	2975	4463	2878	4317	2918	5836				
1190 V											
		Data on request									

① This unit type can be used as large field exciter. Do not forget the SDCS-DSL-H10 (+S521). A 10 % current de-rating is strongly recommended.

② 1190 A_{DC} for 35°C and 1140 A_{DC} for 40°C ambient temperature. ③ As option.

Note:

AC current $I_{AC} = 0.82 * I_{DC}$

Standard duty cycles

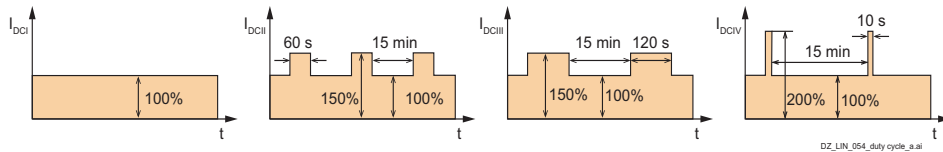

Technical data

Control board SDCS-CON-H01 (H1 ... H8)

The control circuit terminals are common for all sizes H1 ... H8.

Location of the control circuit board SDCS-CON-H01

The SDCS-CON-H01 is mounted on an electronic tray. The electronic tray is attached in the housing by means of two hinges.

Watchdog function

The SDCS-CON-H01 has an internal watchdog. The watchdog controls the proper function of the SDCS-CON-H01 and the firmware. If the watchdog trips, it has the following effects:

- The thyristor firing control is reset and disabled.
- All DI's will not be processed.
- All DO's are frozen in the actual state.
- All AI's will not be processed.
- All programmable AO's are frozen in the actual state.

Recommended wire size - Tightening torques

Control cables:

Wire sizes:	Tightening torques:
0.5 ... 2.5 mm ² (24 ... 12 AWG)	0.5 Nm (5 lbf-in) for both stranded and solid wiring

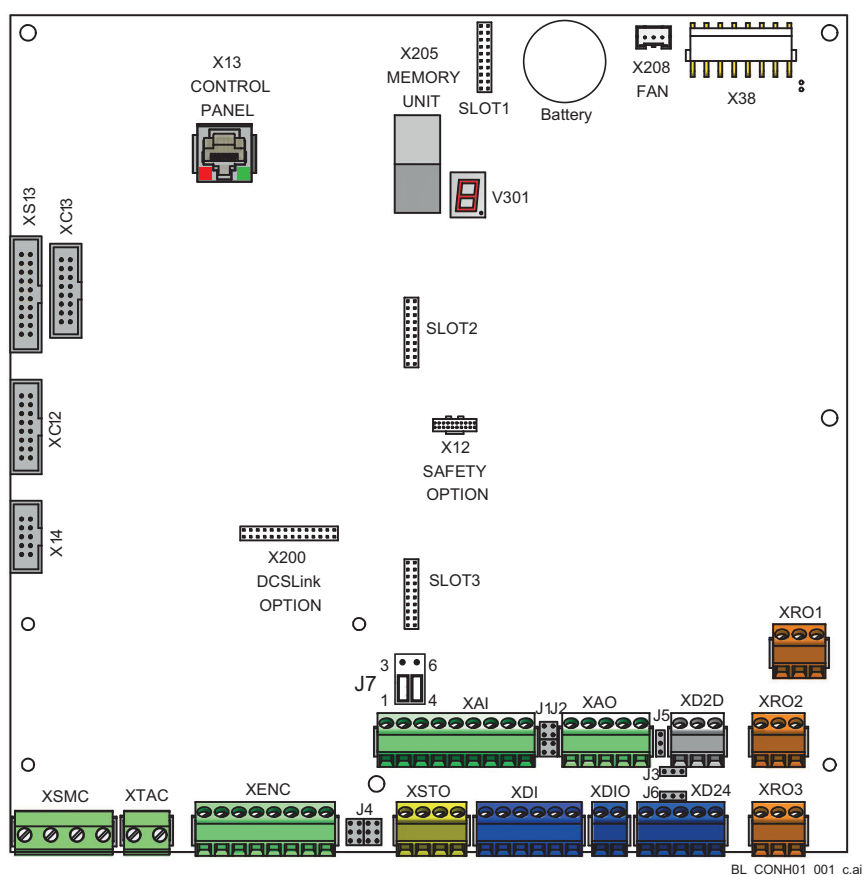

Intermediate cover

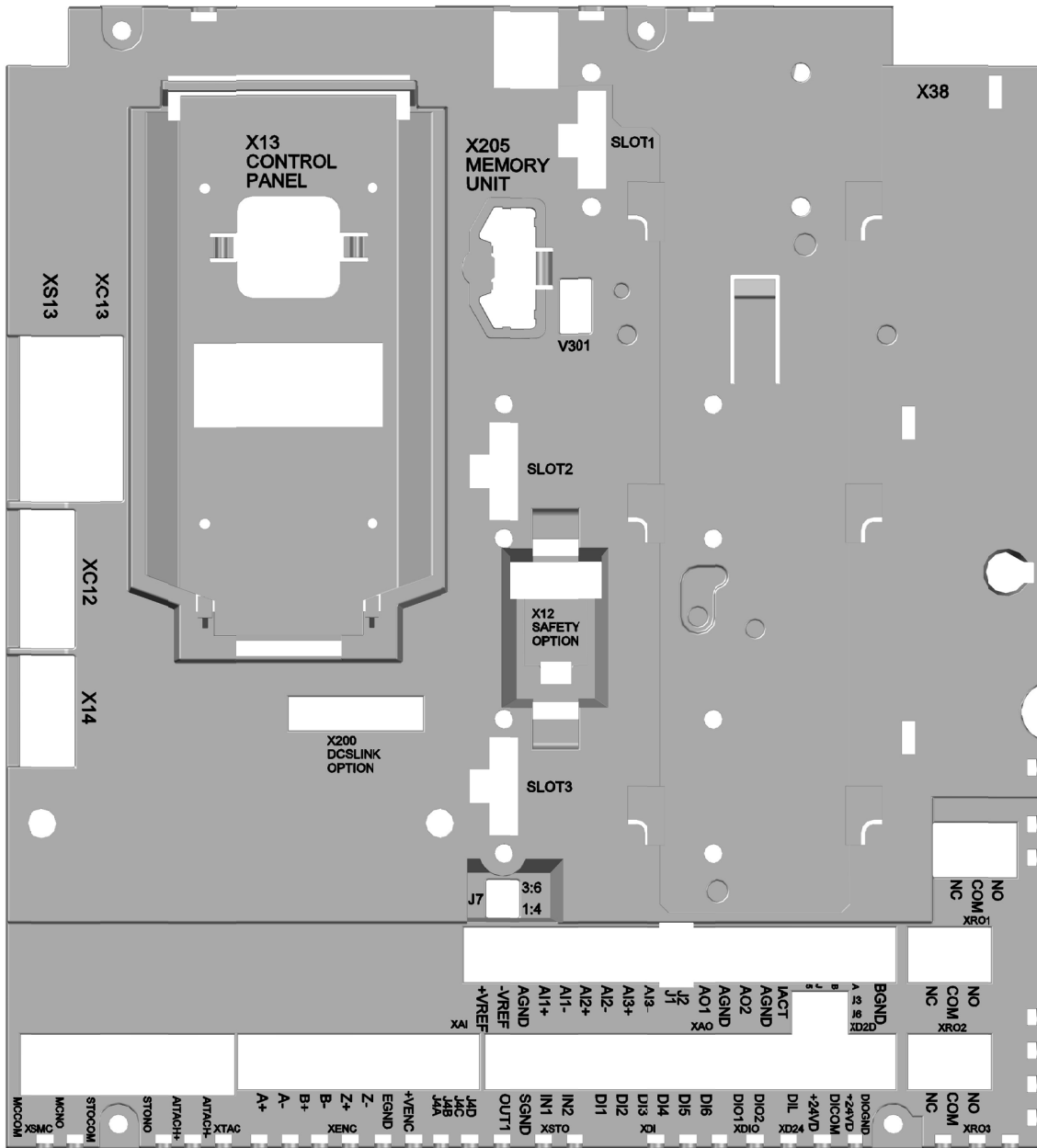

Control circuit terminal layout

Internal 24 V _{DC} used	External 24 V _{DC} used																																																																																																																																																																																																																																																									
DCS880																																																																																																																																																																																																																																																										
<table border="1" style="width:100%; border-collapse: collapse;"> <tr> <th colspan="3">XAI Reference voltage and analog inputs</th> </tr> <tr><td>1</td><td>+VREF</td><td>+10 V_{DC}</td></tr> <tr><td>2</td><td>-VREF</td><td>-10 V_{DC}</td></tr> <tr><td>3</td><td>AGND</td><td>Common ground (connected to frame)</td></tr> <tr><td>4</td><td>AI1+</td><td>±10 V or 0 (4) ... 20 mA depending on J1</td></tr> <tr><td>5</td><td>AI1-</td><td></td></tr> <tr><td>6</td><td>AI2+</td><td>±10 V or 0 (4) ... 20 mA depending on J2</td></tr> <tr><td>7</td><td>AI2-</td><td></td></tr> <tr><td>8</td><td>AI3+</td><td>±10 V</td></tr> <tr><td>9</td><td>AI3-</td><td></td></tr> <tr><td>J1</td><td>J1</td><td>AI1 current / voltage selection jumper</td></tr> <tr><td>J2</td><td>J2</td><td>AI2 current / voltage selection jumper</td></tr> <tr> <th colspan="3">XAO Analog outputs</th> </tr> <tr><td>1</td><td>AO1</td><td>±10 V or 0 (4) ... 20 mA depending on J5</td></tr> <tr><td>2</td><td>AGND</td><td>Common ground (connected to frame)</td></tr> <tr><td>3</td><td>AO2</td><td>±10 V</td></tr> <tr><td>4</td><td>AGND</td><td>Common ground (connected to frame)</td></tr> <tr><td>5</td><td>IACT</td><td>Connection point for a scope (H1 ... H6 only) ①</td></tr> <tr><td>J5</td><td>J5</td><td>AO1 current / voltage selection switch</td></tr> <tr> <th colspan="3">XD2D Drive-to-drive link</th> </tr> <tr><td>1</td><td>B</td><td>Drive-to-drive link</td></tr> <tr><td>2</td><td>A</td><td>(master-follower or embedded fieldbus)</td></tr> <tr><td>3</td><td>BGND</td><td>Isolated ground 2</td></tr> <tr><td>J3</td><td>J3</td><td>Drive-to-drive link termination switch</td></tr> <tr> <th colspan="3">XRO1, XRO2, XRO3 Relay outputs</th> </tr> <tr><td>11</td><td>NC</td><td></td></tr> <tr><td>12</td><td>COM</td><td>250 V_{AC} / 30 V_{DC}</td></tr> <tr><td>13</td><td>NO</td><td>2 A</td></tr> <tr><td>21</td><td>NC</td><td></td></tr> <tr><td>22</td><td>COM</td><td>250 V_{AC} / 30 V_{DC}</td></tr> <tr><td>23</td><td>NO</td><td>2 A</td></tr> <tr><td>31</td><td>NC</td><td></td></tr> <tr><td>32</td><td>COM</td><td>250 V_{AC} / 30 V_{DC}</td></tr> <tr><td>33</td><td>NO</td><td>2 A</td></tr> <tr> <th colspan="3">XD24 Digital interlock</th> </tr> <tr><td>1</td><td>DIL</td><td>Digital interlock, ground: DICOM</td></tr> <tr><td>2</td><td>+24VD</td><td>+24 V_{DC}, 200 mA, ground: DIOGND</td></tr> <tr><td>3</td><td>DICOM</td><td>Isolated digital input ground for DI1 ... DI5 and DIL</td></tr> <tr><td>4</td><td>+24VD</td><td>+24 V_{DC}, 200 mA, ground: DIOGND</td></tr> <tr><td>5</td><td>DIOGND</td><td>Isolated digital input / output ground for DI6, DIO1, DIO2</td></tr> <tr><td>J6</td><td>J6</td><td>Digital ground selection switch (DIOGND and DICOM)</td></tr> <tr> <th colspan="3">XDO Digital inputs / outputs</th> </tr> <tr><td>1</td><td>DIO1</td><td></td></tr> <tr><td>2</td><td>DIO2</td><td></td></tr> <tr> <th colspan="3">XDI Digital inputs</th> </tr> <tr><td>1</td><td>DI1</td><td></td></tr> <tr><td>2</td><td>DI2</td><td></td></tr> <tr><td>3</td><td>DI3</td><td></td></tr> <tr><td>4</td><td>DI4</td><td></td></tr> <tr><td>5</td><td>DI5</td><td></td></tr> <tr><td>6</td><td>DI6</td><td></td></tr> <tr> <th colspan="3">XENC Encoder</th> </tr> <tr><td>1</td><td>A+</td><td>Channel A+ function depending on J4A</td></tr> <tr><td>2</td><td>A-</td><td>Channel A- function depending on J4A</td></tr> <tr><td>3</td><td>B+</td><td>Channel B+ function depending on J4B</td></tr> <tr><td>4</td><td>B-</td><td>Channel B- function depending on J4B</td></tr> <tr><td>5</td><td>Z+</td><td>Channel Z+ function depending on J4C</td></tr> <tr><td>6</td><td>Z-</td><td>Channel Z- function depending on J4C</td></tr> <tr><td>7</td><td>EGND</td><td>Common ground (connected to frame)</td></tr> <tr><td>8</td><td>+VENC</td><td>Encoder supply 5 V_{DC} or 24 V_{DC} depending on J4D, 250 mA</td></tr> <tr><td>J4A</td><td>J4A</td><td>Differential or single ended (10 k pull up)</td></tr> <tr><td>J4B</td><td>J4B</td><td>Differential or single ended (10 k pull up)</td></tr> <tr><td>J4C</td><td>J4C</td><td>Differential or single ended (10 k pull up)</td></tr> <tr><td>J4D</td><td>J4D</td><td>Encoder supply 5 V_{DC} or 24 V_{DC} selection jumper</td></tr> <tr><td>J7A</td><td>J7A</td><td>Not in use for DCS880</td></tr> <tr><td>J7B</td><td>J7B</td><td>Not in use for DCS880</td></tr> <tr> <th colspan="3">XTAC Analog tacho</th> </tr> <tr><td>1</td><td>AITACH+</td><td>±8 ... 270 V_{DC}</td></tr> <tr><td>2</td><td>AITACH-</td><td></td></tr> <tr> <th colspan="3">XSMC Mains contactor</th> </tr> <tr><td>1</td><td>MCCOM</td><td>250 V_{AC} / 30 V_{DC} Fixed output for the mains contactor</td></tr> <tr><td>2</td><td>MCNO</td><td>2 A</td></tr> <tr><td>3</td><td>STOCOM</td><td>250 V_{AC} / 30 V_{DC} Fixed output for safe torque off (STO) zero current monitor</td></tr> <tr><td>4</td><td>STONO</td><td>2 A</td></tr> <tr> <th colspan="3">XSTO Safe torque off (STO)</th> </tr> <tr><td>1</td><td>OUT1</td><td>24 V_{DC} for STO circuit</td></tr> <tr><td>2</td><td>SGND</td><td>Common ground (connected to frame)</td></tr> <tr><td>3</td><td>IN1</td><td>Both circuits must be closed for drive to start</td></tr> <tr><td>4</td><td>IN2</td><td>Open circuits block the firing pulses</td></tr> <tr> <th colspan="3">Safety relays</th> </tr> <tr><td>X12</td><td colspan="2">Safety functions module connection</td></tr> <tr><td>X13</td><td colspan="2">Control panel connection</td></tr> <tr><td>X205</td><td colspan="2">Memory unit connection</td></tr> </table>		XAI Reference voltage and analog inputs			1	+VREF	+10 V _{DC}	2	-VREF	-10 V _{DC}	3	AGND	Common ground (connected to frame)	4	AI1+	±10 V or 0 (4) ... 20 mA depending on J1	5	AI1-		6	AI2+	±10 V or 0 (4) ... 20 mA depending on J2	7	AI2-		8	AI3+	±10 V	9	AI3-		J1	J1	AI1 current / voltage selection jumper	J2	J2	AI2 current / voltage selection jumper	XAO Analog outputs			1	AO1	±10 V or 0 (4) ... 20 mA depending on J5	2	AGND	Common ground (connected to frame)	3	AO2	±10 V	4	AGND	Common ground (connected to frame)	5	IACT	Connection point for a scope (H1 ... H6 only) ①	J5	J5	AO1 current / voltage selection switch	XD2D Drive-to-drive link			1	B	Drive-to-drive link	2	A	(master-follower or embedded fieldbus)	3	BGND	Isolated ground 2	J3	J3	Drive-to-drive link termination switch	XRO1, XRO2, XRO3 Relay outputs			11	NC		12	COM	250 V _{AC} / 30 V _{DC}	13	NO	2 A	21	NC		22	COM	250 V _{AC} / 30 V _{DC}	23	NO	2 A	31	NC		32	COM	250 V _{AC} / 30 V _{DC}	33	NO	2 A	XD24 Digital interlock			1	DIL	Digital interlock, ground: DICOM	2	+24VD	+24 V _{DC} , 200 mA, ground: DIOGND	3	DICOM	Isolated digital input ground for DI1 ... DI5 and DIL	4	+24VD	+24 V _{DC} , 200 mA, ground: DIOGND	5	DIOGND	Isolated digital input / output ground for DI6, DIO1, DIO2	J6	J6	Digital ground selection switch (DIOGND and DICOM)	XDO Digital inputs / outputs			1	DIO1		2	DIO2		XDI Digital inputs			1	DI1		2	DI2		3	DI3		4	DI4		5	DI5		6	DI6		XENC Encoder			1	A+	Channel A+ function depending on J4A	2	A-	Channel A- function depending on J4A	3	B+	Channel B+ function depending on J4B	4	B-	Channel B- function depending on J4B	5	Z+	Channel Z+ function depending on J4C	6	Z-	Channel Z- function depending on J4C	7	EGND	Common ground (connected to frame)	8	+VENC	Encoder supply 5 V _{DC} or 24 V _{DC} depending on J4D, 250 mA	J4A	J4A	Differential or single ended (10 k pull up)	J4B	J4B	Differential or single ended (10 k pull up)	J4C	J4C	Differential or single ended (10 k pull up)	J4D	J4D	Encoder supply 5 V _{DC} or 24 V _{DC} selection jumper	J7A	J7A	Not in use for DCS880	J7B	J7B	Not in use for DCS880	XTAC Analog tacho			1	AITACH+	±8 ... 270 V _{DC}	2	AITACH-		XSMC Mains contactor			1	MCCOM	250 V _{AC} / 30 V _{DC} Fixed output for the mains contactor	2	MCNO	2 A	3	STOCOM	250 V _{AC} / 30 V _{DC} Fixed output for safe torque off (STO) zero current monitor	4	STONO	2 A	XSTO Safe torque off (STO)			1	OUT1	24 V _{DC} for STO circuit	2	SGND	Common ground (connected to frame)	3	IN1	Both circuits must be closed for drive to start	4	IN2	Open circuits block the firing pulses	Safety relays			X12	Safety functions module connection		X13	Control panel connection		X205	Memory unit connection	
XAI Reference voltage and analog inputs																																																																																																																																																																																																																																																										
1	+VREF	+10 V _{DC}																																																																																																																																																																																																																																																								
2	-VREF	-10 V _{DC}																																																																																																																																																																																																																																																								
3	AGND	Common ground (connected to frame)																																																																																																																																																																																																																																																								
4	AI1+	±10 V or 0 (4) ... 20 mA depending on J1																																																																																																																																																																																																																																																								
5	AI1-																																																																																																																																																																																																																																																									
6	AI2+	±10 V or 0 (4) ... 20 mA depending on J2																																																																																																																																																																																																																																																								
7	AI2-																																																																																																																																																																																																																																																									
8	AI3+	±10 V																																																																																																																																																																																																																																																								
9	AI3-																																																																																																																																																																																																																																																									
J1	J1	AI1 current / voltage selection jumper																																																																																																																																																																																																																																																								
J2	J2	AI2 current / voltage selection jumper																																																																																																																																																																																																																																																								
XAO Analog outputs																																																																																																																																																																																																																																																										
1	AO1	±10 V or 0 (4) ... 20 mA depending on J5																																																																																																																																																																																																																																																								
2	AGND	Common ground (connected to frame)																																																																																																																																																																																																																																																								
3	AO2	±10 V																																																																																																																																																																																																																																																								
4	AGND	Common ground (connected to frame)																																																																																																																																																																																																																																																								
5	IACT	Connection point for a scope (H1 ... H6 only) ①																																																																																																																																																																																																																																																								
J5	J5	AO1 current / voltage selection switch																																																																																																																																																																																																																																																								
XD2D Drive-to-drive link																																																																																																																																																																																																																																																										
1	B	Drive-to-drive link																																																																																																																																																																																																																																																								
2	A	(master-follower or embedded fieldbus)																																																																																																																																																																																																																																																								
3	BGND	Isolated ground 2																																																																																																																																																																																																																																																								
J3	J3	Drive-to-drive link termination switch																																																																																																																																																																																																																																																								
XRO1, XRO2, XRO3 Relay outputs																																																																																																																																																																																																																																																										
11	NC																																																																																																																																																																																																																																																									
12	COM	250 V _{AC} / 30 V _{DC}																																																																																																																																																																																																																																																								
13	NO	2 A																																																																																																																																																																																																																																																								
21	NC																																																																																																																																																																																																																																																									
22	COM	250 V _{AC} / 30 V _{DC}																																																																																																																																																																																																																																																								
23	NO	2 A																																																																																																																																																																																																																																																								
31	NC																																																																																																																																																																																																																																																									
32	COM	250 V _{AC} / 30 V _{DC}																																																																																																																																																																																																																																																								
33	NO	2 A																																																																																																																																																																																																																																																								
XD24 Digital interlock																																																																																																																																																																																																																																																										
1	DIL	Digital interlock, ground: DICOM																																																																																																																																																																																																																																																								
2	+24VD	+24 V _{DC} , 200 mA, ground: DIOGND																																																																																																																																																																																																																																																								
3	DICOM	Isolated digital input ground for DI1 ... DI5 and DIL																																																																																																																																																																																																																																																								
4	+24VD	+24 V _{DC} , 200 mA, ground: DIOGND																																																																																																																																																																																																																																																								
5	DIOGND	Isolated digital input / output ground for DI6, DIO1, DIO2																																																																																																																																																																																																																																																								
J6	J6	Digital ground selection switch (DIOGND and DICOM)																																																																																																																																																																																																																																																								
XDO Digital inputs / outputs																																																																																																																																																																																																																																																										
1	DIO1																																																																																																																																																																																																																																																									
2	DIO2																																																																																																																																																																																																																																																									
XDI Digital inputs																																																																																																																																																																																																																																																										
1	DI1																																																																																																																																																																																																																																																									
2	DI2																																																																																																																																																																																																																																																									
3	DI3																																																																																																																																																																																																																																																									
4	DI4																																																																																																																																																																																																																																																									
5	DI5																																																																																																																																																																																																																																																									
6	DI6																																																																																																																																																																																																																																																									
XENC Encoder																																																																																																																																																																																																																																																										
1	A+	Channel A+ function depending on J4A																																																																																																																																																																																																																																																								
2	A-	Channel A- function depending on J4A																																																																																																																																																																																																																																																								
3	B+	Channel B+ function depending on J4B																																																																																																																																																																																																																																																								
4	B-	Channel B- function depending on J4B																																																																																																																																																																																																																																																								
5	Z+	Channel Z+ function depending on J4C																																																																																																																																																																																																																																																								
6	Z-	Channel Z- function depending on J4C																																																																																																																																																																																																																																																								
7	EGND	Common ground (connected to frame)																																																																																																																																																																																																																																																								
8	+VENC	Encoder supply 5 V _{DC} or 24 V _{DC} depending on J4D, 250 mA																																																																																																																																																																																																																																																								
J4A	J4A	Differential or single ended (10 k pull up)																																																																																																																																																																																																																																																								
J4B	J4B	Differential or single ended (10 k pull up)																																																																																																																																																																																																																																																								
J4C	J4C	Differential or single ended (10 k pull up)																																																																																																																																																																																																																																																								
J4D	J4D	Encoder supply 5 V _{DC} or 24 V _{DC} selection jumper																																																																																																																																																																																																																																																								
J7A	J7A	Not in use for DCS880																																																																																																																																																																																																																																																								
J7B	J7B	Not in use for DCS880																																																																																																																																																																																																																																																								
XTAC Analog tacho																																																																																																																																																																																																																																																										
1	AITACH+	±8 ... 270 V _{DC}																																																																																																																																																																																																																																																								
2	AITACH-																																																																																																																																																																																																																																																									
XSMC Mains contactor																																																																																																																																																																																																																																																										
1	MCCOM	250 V _{AC} / 30 V _{DC} Fixed output for the mains contactor																																																																																																																																																																																																																																																								
2	MCNO	2 A																																																																																																																																																																																																																																																								
3	STOCOM	250 V _{AC} / 30 V _{DC} Fixed output for safe torque off (STO) zero current monitor																																																																																																																																																																																																																																																								
4	STONO	2 A																																																																																																																																																																																																																																																								
XSTO Safe torque off (STO)																																																																																																																																																																																																																																																										
1	OUT1	24 V _{DC} for STO circuit																																																																																																																																																																																																																																																								
2	SGND	Common ground (connected to frame)																																																																																																																																																																																																																																																								
3	IN1	Both circuits must be closed for drive to start																																																																																																																																																																																																																																																								
4	IN2	Open circuits block the firing pulses																																																																																																																																																																																																																																																								
Safety relays																																																																																																																																																																																																																																																										
X12	Safety functions module connection																																																																																																																																																																																																																																																									
X13	Control panel connection																																																																																																																																																																																																																																																									
X205	Memory unit connection																																																																																																																																																																																																																																																									
	<p style="text-align: right;">SA_880_010_DCT-PLC_a.ai</p>																																																																																																																																																																																																																																																									
	<table border="1" style="width:100%; border-collapse: collapse;"> <tr> <th colspan="3">J4 Encoder</th> <th colspan="2">Encoder supply</th> </tr> <tr> <td>A</td><td>B</td><td>C</td> <td>D</td><td></td> </tr> <tr> <td>1</td><td>4</td><td>7</td> <td>10</td><td>24 V</td> </tr> <tr> <td>3</td><td>6</td><td>9</td> <td>12</td><td>5 V default</td> </tr> </table> <p style="text-align: center;">OnBoard Encoder Feedback 24 V ↓ 5 V</p>	J4 Encoder			Encoder supply		A	B	C	D		1	4	7	10	24 V	3	6	9	12	5 V default																																																																																																																																																																																																																																					
J4 Encoder			Encoder supply																																																																																																																																																																																																																																																							
A	B	C	D																																																																																																																																																																																																																																																							
1	4	7	10	24 V																																																																																																																																																																																																																																																						
3	6	9	12	5 V default																																																																																																																																																																																																																																																						
	<p>① For H7 and H8 see SDCS-OPL-H01.</p> <p style="text-align: right;">SA_880_005_DCS_d.ai</p>																																																																																																																																																																																																																																																									

XAI: Reference voltages and analog inputs

+VREF	+10 V _{DC} , ±1 % R _L = 1 ... 10 kΩ Maximum wire size 2.5 mm ²
-VREF	-10 V _{DC} , ±1 % R _L = 1 ... 10 kΩ Maximum wire size 2.5 mm ²
AI1+	±10 V [R _{in} ≥ 200 kΩ], 0 (4) ... 20 mA or ±20 mA [R _{in} = 100 Ω] depending on J1
AI1-	Maximum wire size 2.5 mm ² Differential inputs, common mode range ±30 V Sampling interval per channel: 0.25 ms Hardware filter: 0.25 ms Resolution: 15 bit + sign Inaccuracy: 1 % of full scale range
AI2+	±10 V [R _{in} ≥ 200 kΩ], 0 (4) ... 20 mA or ±20 mA [R _{in} = 100 Ω] depending on J2
AI2-	Maximum wire size 2.5 mm ² Differential inputs, common mode range ±30 V Sampling interval per channel: 0.25 ms Hardware filter: 0.25 ms Resolution: 15 bit + sign Inaccuracy: 1 % of full scale range
AI3+	±10 V [R _{in} ≥ 200 kΩ]
AI3-	Maximum wire size 2.5 mm ² Differential inputs, common mode range ±30 V Sampling interval per channel: 0.25 ms Hardware filter: 0.25 ms Resolution: 15 bit + sign Inaccuracy: 1 % of full scale range
	Parameter settings see DCS880 Firmware manual Group 12 Standard AI

XAO: Analog outputs

AO1	±10 V [load current ≤ 10 mA] or 0 (4) ... 20 mA [R _L ≤ 500 Ω] depending on J5 Maximum wire size 2.5 mm ² Frequency range: 0 ... 300 Hz Resolution: 11 bit + sign Inaccuracy: 2 % of full scale range
AO2	±10 V [load current ≤ 10 mA] Maximum wire size 2.5 mm ² Frequency range: 0 ... 300 Hz Resolution: 11 bit + sign Inaccuracy: 2 % of full scale range
IACT	Connection point for a scope to measure the current directly over the burden resistor (H1 ... H6 only. For H7 and H8 see SDCS-OPL-H01). Scaling see 13.80 Scaling of fixed current output.
	Parameter settings see DCS880 Firmware manual Group 13 Standard AO

XD2D: Drive-to-drive link

B	Maximum wire size 2.5 mm ²
A	Physical layer: RS-485 Termination by switch J3
	Parameter settings see DCS880 Firmware manual Group 60 DDCS communication

The drive-to-drive link is a daisy-chained RS-485 transmission line that allows basic master-follower communication with one master and multiple followers. It is also used for the embedded fieldbus.

Set the termination switch J3 (see [Jumpers and switches](#)) next to terminal block XD2D to terminated (■) at the two physical ends of the drive-to-drive link. All intermediate switches have to be set to not terminated (□).

Use double shielded twisted-pair cable ($\sim 100 \Omega$, for example, PROFIBUS compatible cable) for the wiring. For best immunity, high quality cable is recommended. Keep the cable as short as possible. The maximum complete length of the link is 50 meters. Avoid unnecessary loops and running the link near power cables. The following diagram shows the wiring of the drive-to-drive link.

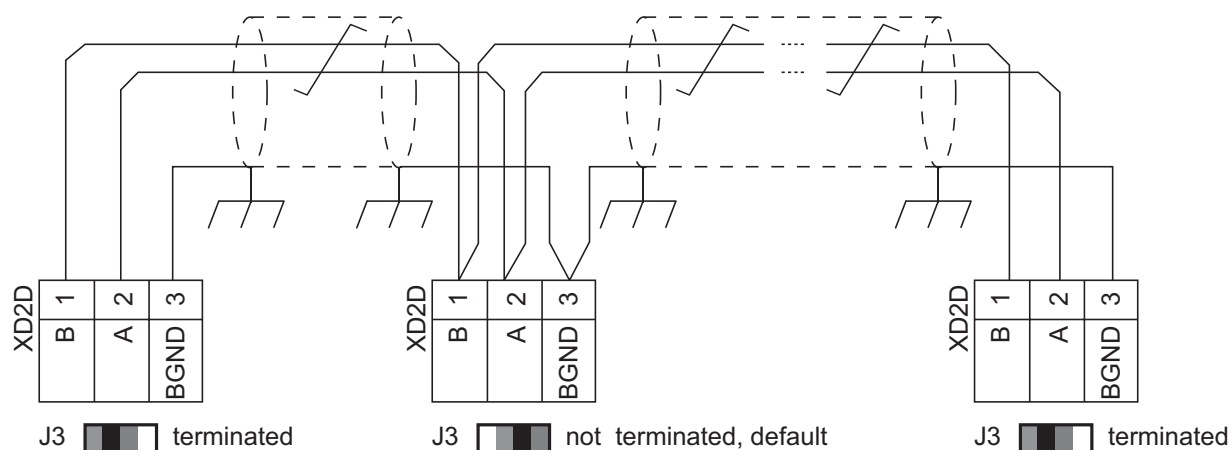

SF_880_008_DCT_drive2drive_b.ai

RO1, RO2, RO3: Relay outputs

NC	250 V _{AC} / 30 V _{DC} , 2 A
COM	Maximum wire size 2.5 mm ²
NO	Varistor protected
	Parameter settings see DCS880 Firmware manual Group 10 Standard DI, RO

XD24: Digital interlock

DIL	<p>The digital interlock works like a normal digital input and has no special function in the DCS880. It can be selected for example as the source for an emergency stop command or any other external event. See the DCS880 Firmware manual for more information.</p> <p>Maximum wire size 2.5 mm²</p> <p>+24 V_{DC} logic levels: low < 5 V_{DC}, high > 15 V_{DC}</p> <p>R_{in} = 2 kΩ</p> <p>Hardware filter: 0.04 ms</p> <p>Digital filter up to 8 ms</p> <p>Related ground is DICOM</p>
+24VD	<p>+24 V_{DC}, 200 mA</p> <p>Total load power of these outputs is 4.8 W (200 mA, 24 V_{DC}) minus the power taken by DIO1 and DIO2</p> <p>Maximum wire size 2.5 mm²</p> <p>Related ground is DIOGND</p>
	Parameter settings see DCS880 Firmware manual Group 10 Standard DI, RO

XDIO: Digital inputs / outputs

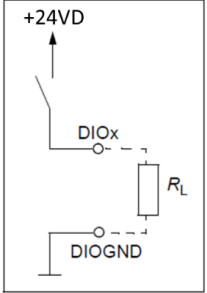
DIO1	Maximum wire size 2.5 mm ²
DIO2	<p>As input: +24 V_{DC} logic levels: low < 5 V_{DC}, high > 15 V_{DC} R_{in} = 2 kΩ Filter: 0.25 ms</p> <p>As output: Total output current from +24VD is limited to 200 mA</p>  <p>Filter: 0.04 ms Related ground is DIOGND</p>
Parameter settings see DCS880 Firmware manual Group 11 Standard DIO, FI, FO	

XDI: Digital inputs

DI1	Maximum wire size 2.5 mm ²
DI2	+24 V _{DC} logic levels: low < 5 V _{DC} , high > 15 V _{DC}
DI3	R _{in} = 2 kΩ
DI4	Hardware filter: 0.04 ms
DI5	Digital filter up to 8 ms
DI6	DI1 ... DI5: Related ground is DICOM
DI6	DI6: Related ground is DIOGND
Parameter settings see DCS880 Firmware manual Group 10 Standard DI, RO	

XENC: Encoder

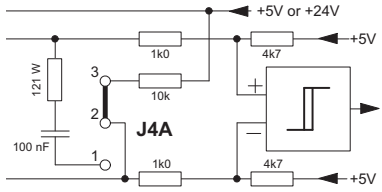
A+	OnBoard encoder interface supply voltage 5 V or 24 V (non isolated) depending on J4D, 250 mA
A-	OnBoard encoder interface type differential or single ended depending on J4A ... J4C
B+	Maximum wire size 2.5 mm ²
B-	
Z+	
Z-	
EGND	
+VENC	
SDCS-CON-H01 ENCODER INPUT A	
Parameter settings see DCS880 Firmware manual Group 94 OnBoard speed feedback configuration	

XTAC: Analog tacho

AITACH+	OnBoard tacho interface
AITACH-	Maximum wire size 2.5 mm ² Differential input max. voltage 8 ... 270 V
Parameter settings see DCS880 Firmware manual Group 94 OnBoard speed feedback configuration	

XSMC: Mains contactor

MCCOM	Fixed output for the mains contactor
MCNO	250 V _{AC} / 30 V _{DC} , 2 A Maximum wire size 2.5 mm ² Varistor protected
STOCOM	Fixed output for safe torque off (STO) zero current monitor
STONO	250 V _{AC} / 30 V _{DC} , 2 A Maximum wire size 2.5 mm ² Varistor protected
	Mains contactor ON command: 06.24.b07 Current controller status word 1

XSTO: Safe torque off

OUT1	For the drive to start, both connections (OUT1 to IN1 and IN2) must be closed. By default, the terminal block has wires to close the circuit. Removing the wires will block the firing pulses. Maximum wire size 2.5 mm ² Current consumption per channel: 55 mA (continuous)
IN1	
IN2	

X205 Memory unit connection

The drive is equipped with a memory unit that is plugged into X205 on the SDCS-CON-H01. The memory unit contains the firmware, the parameters and the application program (as option). It is possible to handle the parameters by control panel, PC tool or overriding control. Changed parameters are stored immediately in the memory unit.

In addition, the fault logger entries are stored in the memory unit during de-energizing the auxiliary power.

When a drive is replaced, the parameter settings can be retained by transferring the memory unit from the defective drive to the new drive.

**WARNING**

Do not remove or insert a memory unit when the drive is powered.

After power-up, the drive will scan the memory unit. If different parameter settings are detected, they are copied to the drive. This may take several minutes.

Replacing the memory unit

Make sure, that the auxiliary power is off. Unscrew the memory unit and pull it out. Replace the memory unit in reverse order.

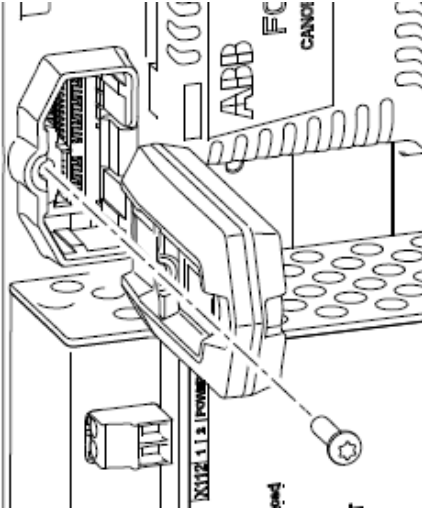

Additional terminals

- Use connectors Slot1 ... Slot3 for F-type I/O extension modules and F-type fieldbus adapters.
- Connectors XC12, XS13, X14 and X38 connect the SDCS-CON-H01 to the SDCS-PIN-H01 or SDCS-POW-H01 for voltage, current, temperature measurement and safety.
- Use connector X13 to connect the control panel either directly via a jack plug or via a CAT 1:1 cable (< 3 m) with RJ-45 plugs.

Ground isolation diagram

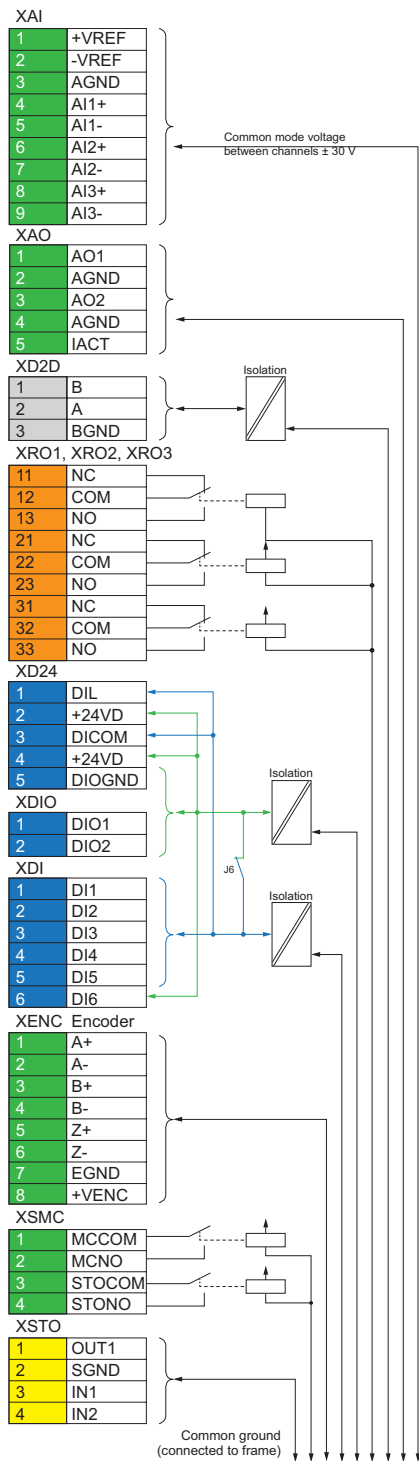

SA_880_012_DCS_b.ai





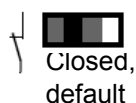
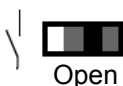

Switch J6 settings:

The ground (DICOM) of digital inputs DI1 ... DI5 and DIL is separated from the ground (DIOGND) of digital inputs / outputs DIO1, DIO2 and DI6. The insulation voltage between them is 50 V.

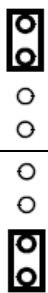
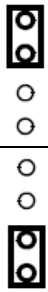

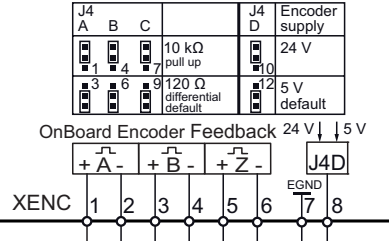
All digital inputs and outputs share the same ground, default.

Jumpers and switches

Jumper / Switch	Description	Positions
J1 (AI1)	Determines whether analog input AI1 is used as a current or voltage input.	 <p>Current (I)</p> <p>Voltage (U), default.</p>
J2 (AI2)	Determines whether analog input AI2 is used as a current or voltage input.	 <p>Current (I)</p> <p>Voltage (U), default.</p>
J3 (D2D)	Drive-to-drive link termination. Must be set to terminated position when the thyristor power controller is the last unit on the link.	 <p>Bus is not terminated, default.</p> <p>Bus is terminated.</p>
J4A ... J4D (encoder)	OnBoard encoder interface.	
J5 (AO1)	Determines whether analog output AO1 is used as a current or voltage output.	 <p>Voltage (U), default.</p> <p>Current (I)</p>
J6 (grounding)	Digital ground selection switch. Determines whether DICOM is separated from DIOGND (e.g. the common reference for digital inputs floats). See Ground isolation diagram . The insulation voltage between them is 50 V.	 <p>DIOGND and DICOM separated.</p> <p>DIOGND and DICOM connected, default.</p>
J7A, J7B	OnBoard encoder interface.	 <p>Encoder, default.</p> <p>Not in use for DCS880.</p>

DDCS Interface configuration

Ch0 DriveBus or module bus connection to Advant Controller (star)

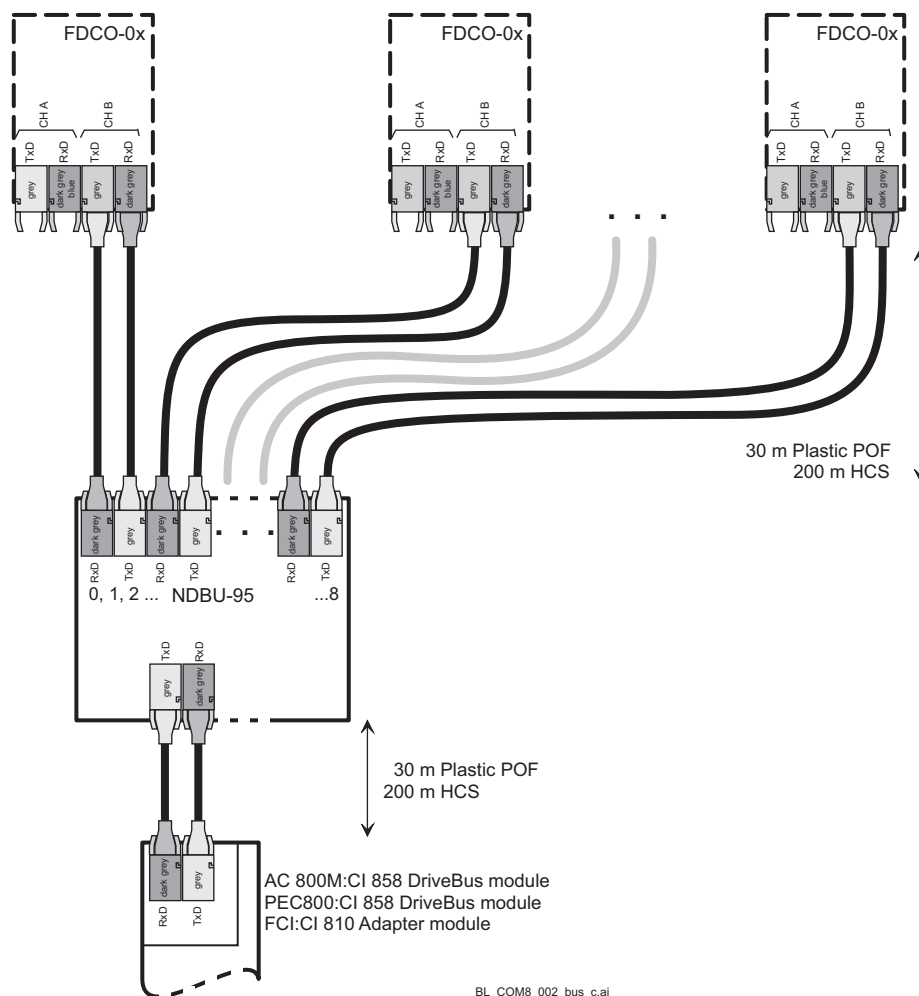

DDCS branching unit NDBU-95

The NDBU-95 is used to implement star topology for DDCS communication. This allows a drive to fail or become unpowered without disabling the complete communication. The NDBU-95 receives messages from the master (e.g. PC) and sends them to all the drives simultaneously. Each drive has an individual address and only the addressed drive sends a reply message to the master.

NDBU-95 has nine output channels. The reply message sent by a drive is delivered to the master. Several NDBU-95s can be used in parallel, in series or in any combination of these. The maximum distance between the master and a NDBU-95 as well as between two NDBU-95s, see manual [Branching units NDBU-95](#).

Technical data

Layout of the NDBU-95

Optical links:

Master channels	1 DDCS input and 1 DDCS output
Drive channels	9 DDCS inputs and 9 DDCS outputs
Data rate	1 ... 4 Mbit/s, (see X12)
Driving current	20 mA, 30 mA, 50 mA, channel disabling, (see X2 ... X11)
Monitoring	A green LED for each channel is switched on, when messages are received
Transmission device	10 Mb components

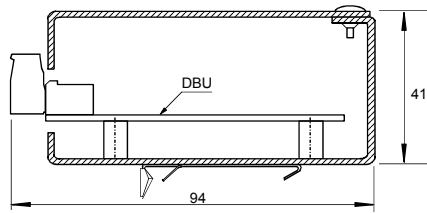

Power supply:

Input voltage	+24 V _{DC} ±10 %
Input current	300 mA
Monitoring	A green LED is switched on, when the output voltage is normal

Operating temperature: +0 ... +50°C

Dimensions: See diagram

Note: Only channels with the same hardware components (e.g. 10 Mb component) are allowed to be connected together.

For further information see [Branching units NDBU-95](#).

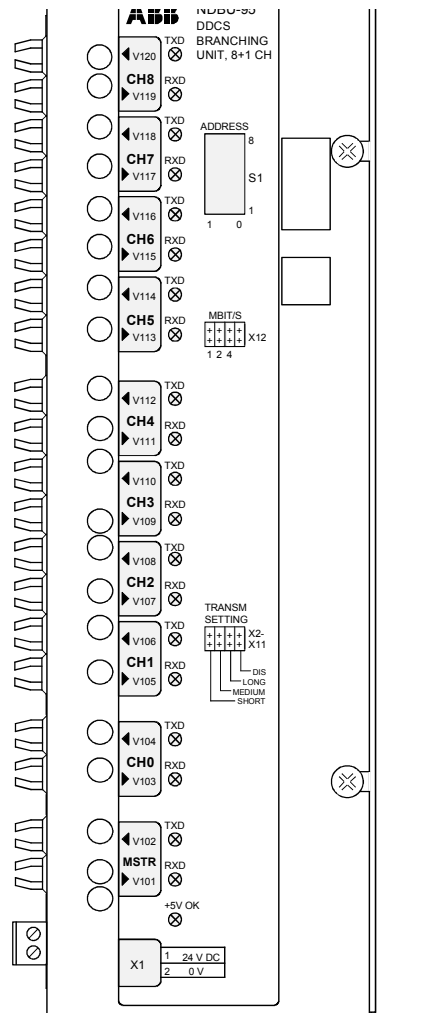

DCSLink board SDCS-DSL-H1x (H1 ... H8)

The SDCS-DSL-H1x provides communication between drives. The communication hardware and protocol is based on CAN bus.

This communication will be used for drive-to-drive communication, 12-pulse operation and communication to field exciters.

The communication hardware is equipped with an isolated power supply and an isolated transmitter. The bus termination can be set by jumper J1. See also chapter [DCSLink communication](#).

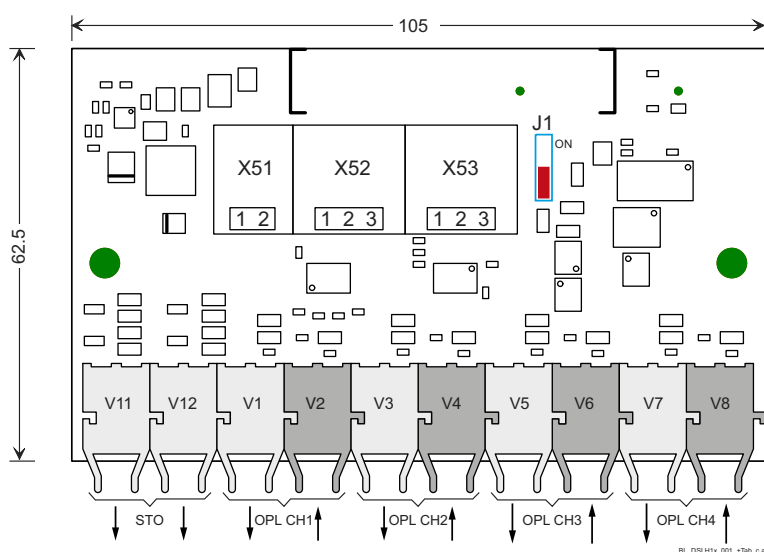

Jumper coding	
J1 Bus termination	
	OFF (default)
	ON = 120 Ω

BL_DSLH1x_001_Tab_b.ai

SDCS-DSL-H1x

SDCS-DSL-H10	1 DCSLink channel, 0 channels optical power link
SDCS-DSL-H12	1 DCSLink channel, 2 channels optical power link
SDCS-DSL-H14	1 DCSLink channel, 4 channels optical power link

SDCS-DSL-H1x

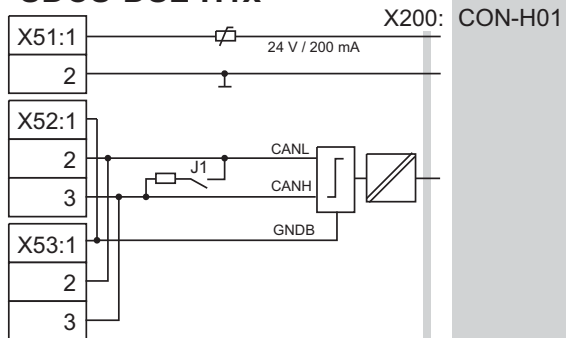

SA_DSL_002_DSLH1x_b.ai

Supply	Remarks
24 V	≤ 200 mA
24 V grounded supply for DCF803-0016, FEX-425-Int and DCF803-0035 field exciters; short circuit protected.	

- X51 supplies 24 V_{DC}.
- X52 and X53 are connected in parallel and provide two connectors for the DCSLink.

Notes:

- Maximum total DCSLink cable length is 100 m.
- Maximum length of the plastic optical fiber cable between SDCS-DSL-H12 / H14 and SDCS-OPL-H01 is 5 m.

Daisy chain DPI-H01 kit (H1 ... H8)

Daisy chain adapters are used to connect several drives to one control panel or to a PC via a control panel. Maximum of 32 nodes are possible. The control panel / PC is the master, while the drives equipped with a daisy chain adapter are followers.

Note:

The DPI-H01 kit can be ordered together with the drives using pluscode +J428.

Contents of the kit

- ① Plastic cover.
- ② SDCS-DPI-H01 adapter.
- ③ Patch cable.
- ④ Grounding cable plus screw.
- ⑤ Stand offs.

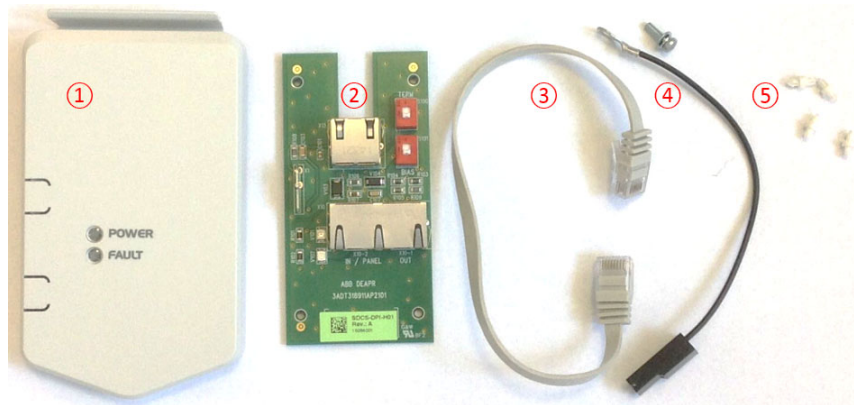

- ① Clip to attach the plastic cover.
- ② Status LEDs via light pipes.
- ③ X13 for the patch cable to the unit.
- ④ Termination switch (S100).
- ⑤ Bias switch (S101).

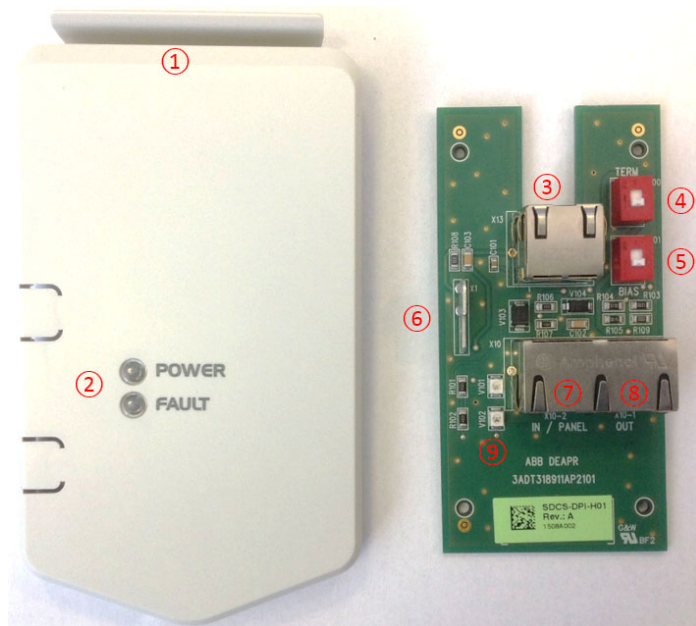
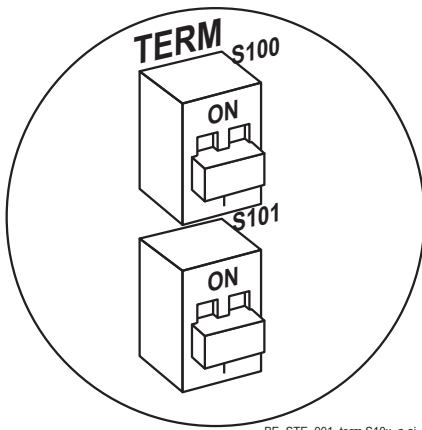

- ⑥ X1 for grounding.
- ⑦ X10-1 (IN / PANEL) for control panel.
- ⑧ X10-2 (OUT) for the next unit.
- ⑨ Status LEDs:

Name	Color	Description
POWER	Green	The unit is powered.
FAULT	Red	The unit has an active fault.

Technical data

Installation

1. Inset the four stand offs into the intermediate cover.
2. Connect the patch cable between X13 on the SDCS-CON-H01 and X13 on the SDCS-DPI-H01 adapter.
3. Plug the SDCS-DPI-H01 adapter onto the standoffs.
4. Connect the grounding cable at X1 and the grounding standoff using the screw.
5. Connect the cables to the control panel / a drive using X10:2 and X10:1.

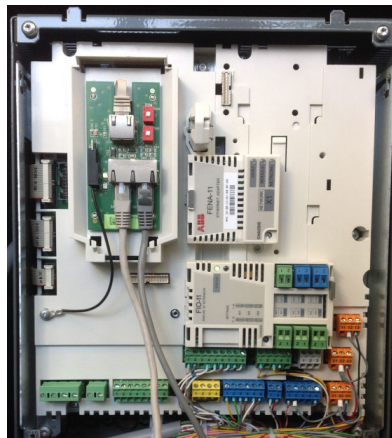

6. Attach the plastic cover.

7. Attach the front cover

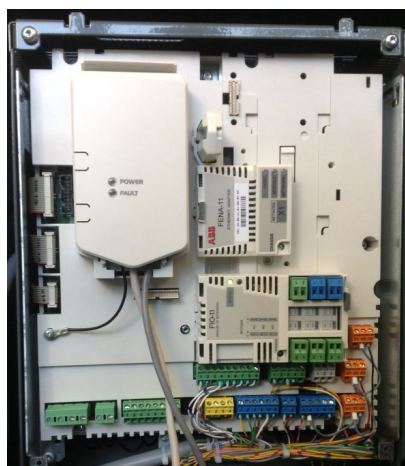

Chaining a control panel

This figure shows how to chain a control panel to several drives:

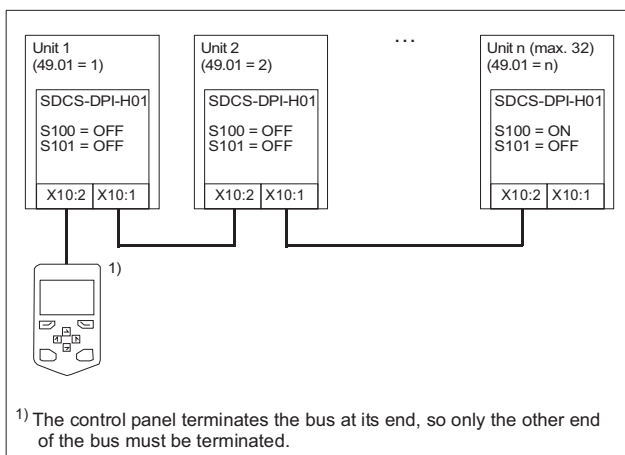

Chaining a PC via a control panel

This figure shows how to chain a PC via a control panel to several drives.

Note: When a control panel is used for a PC connection, it cannot be used to operate the drives.

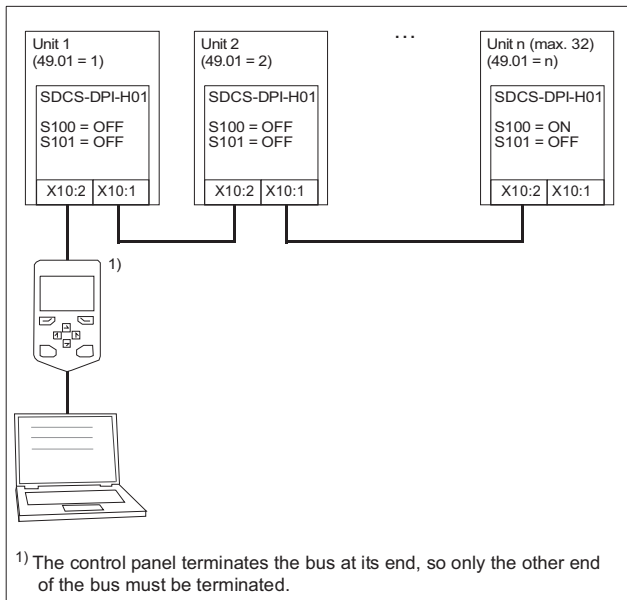

Setting up the firmware

1. Power up the unit.
2. Set the node ID, see 49.01 Node ID number. All drives connected to the panel bus must have a unique node ID. It is advisable to reserve node ID 1 for spare / replacement drives, because they have node ID 1 as the default setting.
3. Set the baud rate, see 49.03 Baud rate. The baud rate has to be the same for all nodes on the panel bus.
4. Select a suitable communication loss action, see 49.04 Communication loss time and 49.05 Communication loss action.
5. Save the settings with 49.06 Refresh settings = Refresh.

Note: Refreshing may cause a communication break, thus reconnecting the drives may be required.

Power Interface board SDCS-PIN-H01 (H1 ... H5)

The SDCS-PIN-H01 is designed for DCS880 converter modules sizes H1 ... H5 (20 A ... 1190 A). It has 4 different functions:

1. The power supply for all internal voltages of the whole drive and the connected options (H1 ... H5).
2. Control of armature bridge including high ohmic measurement of DC- and AC voltage and an interface for the current transformer measuring the armature current (H1 ... H5).
3. Control of the OnBoard field exciter and field current measurement (H1 ... H4).
4. An automatic adaptation of the auxiliary voltage of either 230 V_{AC} or 115 V_{AC} (H1 ... H5).

The board is connected to ground at points () inside the module.

The board is used for mains supply voltages from 100 V up to 500 V (IEC) / 525 V (UL) and 600 V.

The DCS880 provides an automatic adjustment for current and voltage measurement, burden resistor settings and 2-Q or 4-Q operation by means of setting parameters in the firmware.

Layout SDCS-PIN-H01

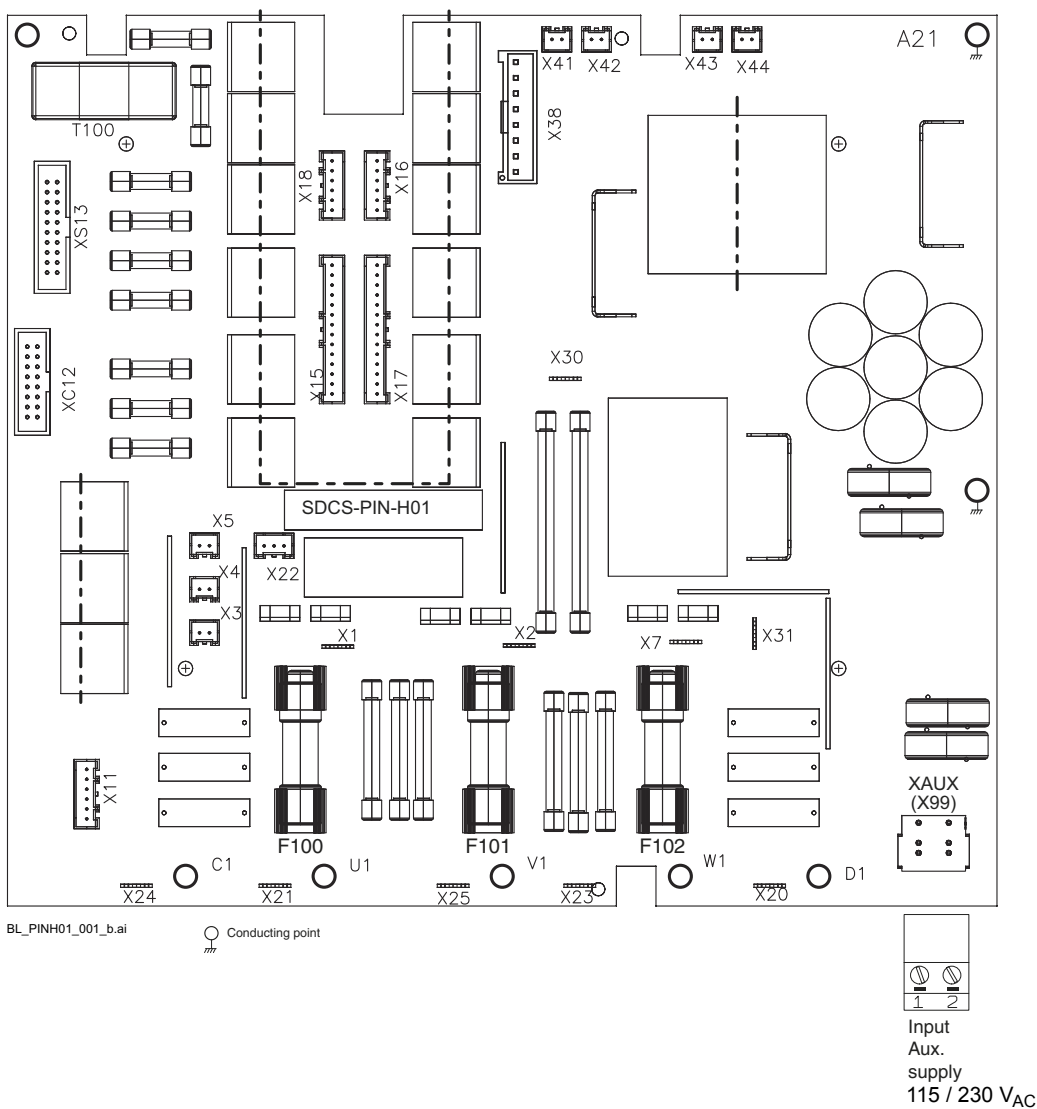

Technical data

Auxiliary supply voltage XAUX (X99)

Auxiliary voltage	115 V _{AC}	230 V _{AC}	230 V _{DC}
Tolerance	-15 % / +10 %	-15 % / +10 %	-15 % / +10 %
Frequency	45 Hz ... 65 Hz	45 Hz ... 65 Hz	-
Power consumption	120 VA	120 VA	-
Power loss	≤ 60 W	≤ 60 W	≤ 60 W
Inrush current	20 A / 20 ms	10 A / 20 ms	10 A / 20 ms
Recommended fusing	6 AT	6 AT	6 AT
Mains buffering	min. 30 ms	min. 300 ms	min. 150 ms
Powerfail	< 95 V _{AC}	< 95 V _{AC}	< 140 V _{DC}

Input circuit XAUX (X99)

Features a hardware filter and a voltage limitation

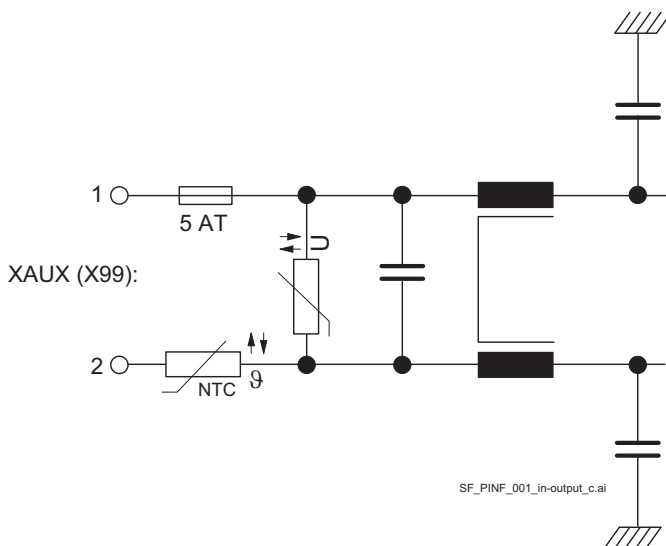

Armature circuit interface

The function for the armature circuit interface consist of:

- Firing the armature bridge of 6 or 12 thyristors.
- High ohmic measurement of DC and AC voltages.
- Residual current measurement of armature circuit to ground = 5 mA at 500 V supply ($\approx 1 \text{ M}\Omega$).
- Interface for the current transformers for current measurement.
- Snubber circuit for the thyristor protection together with R1 on the heatsink.
- Interface for heatsink temperature measurement with a PTC.
- Fuses for overvoltage protection and field circuit.

Power supply board SDCS-POW-H01 (H6 ... H8)

The SDCS-POW-H01 is designed for DCS880 converter modules and is mounted on the electronic tray. It is used for sizes H6, H7, H8 and the rebuild kit DCS880-R.

The SDCS-POW-H01 generates all necessary DC voltages for the SDCS-CON-H01 and all other electronic boards. The input voltage is automatically detected and set to either 230 V_{AC} or 115 V_{AC}.

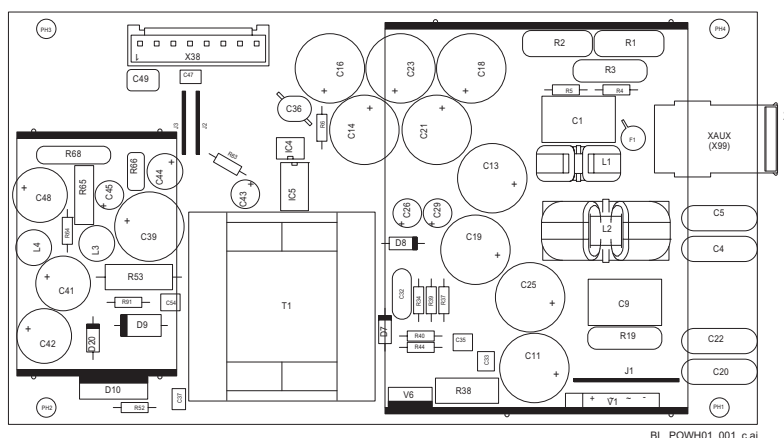

- X38 connection control board

Technical data

Auxiliary supply voltage XAUX (X99)

Supply voltage	115 V _{AC}	230 V _{AC}	230 V _{DC}
Tolerance	-15 % / +10 %	-15 % / +10 %	-15 % / +10 %
Frequency	45 Hz - 65 Hz	45 Hz - 65 Hz	-
Power consumption	120 VA	120 VA	120 VA
Power loss	≤ 60 W	≤ 60 W	≤ 60 W
Inrush current ①	20 A / 20 ms	10 A / 20 ms	15 A / 20 ms
Recommended fusing	6 AT	6 AT	6 AT
Mains buffering	min. 30 ms	min. 300 ms	min. 150 ms
Powerfail	95 V	95 V	100 V

① Frequently switching ON and OFF increases the inrush current.

Input circuit XAUX (X99)

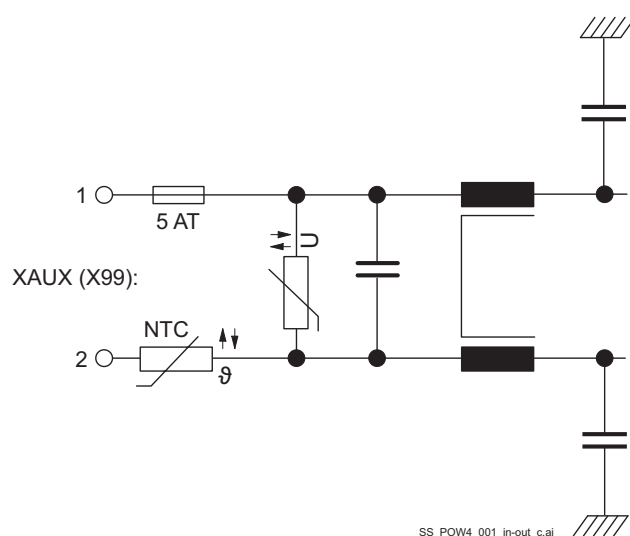

Field circuit interfaces SDCS-BAB-F01 and SDCS-BAB-F02 (H1 ... H4)

The OnBoard field exciter is located internally. The firing pulses are synchronized using the mains circuit L1, L2, L3 and the SDCS-CON-H01. The pulses are amplified on the SDCS-PIN-H01.

The hardware structure is a three phase half controlled bridge supplied directly from the mains U1, V1, W1 via fuses F100, F101, F102.

If the OnBoard field exciter is not needed it can be deselected in the firmware.

The field circuit interface consists of:

- Firing the three phase half controlled field bridge.
- Measuring the field current on the DC side. The scaling is automatically selected using the rated motor field current.
- The snubber circuit is shared with the armature bridge.
- Fuses F100, F101, F102 are used for cable and motor field winding protection.
- Size H3 and H4 converters for 600 V are always delivered without OnBoard field exciter.
- Size H5 converters do not use the field circuit interface on the SDCS-PIN-H01

Ratings OnBoard field exciter

AC voltage range	110 ... 500 V (IEC) / 525 V (UL)
AC insulation voltage	600 V
Frequency	50 Hz / 60 Hz
AC input current	< Field current

Cables

Size	H1	H1	H2	H3	H4
DC output current	6 A / 12 A	12 A	18 A	25 A	30 A
max. cross sectional area	6 mm ² AWG 10	6 mm ² AWG 10	6 mm ² AWG 10	6 mm ² AWG 10	6 mm ² AWG 10
min. cross sectional area	1 mm ² AWG 16	2.5 mm ² AWG 13	4 mm ² AWG 11	6 mm ² AWG 10	6 mm ² AWG 10

Layout

SDCS-BAB-F01 for module sizes H1 and H2:

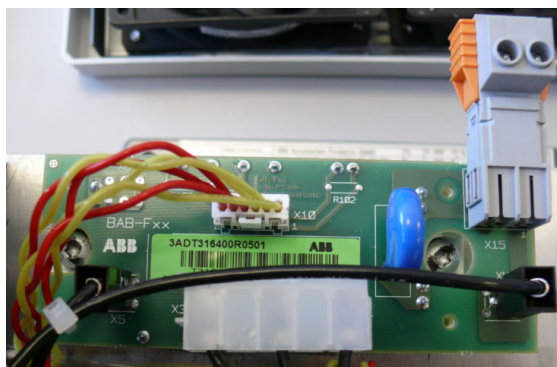
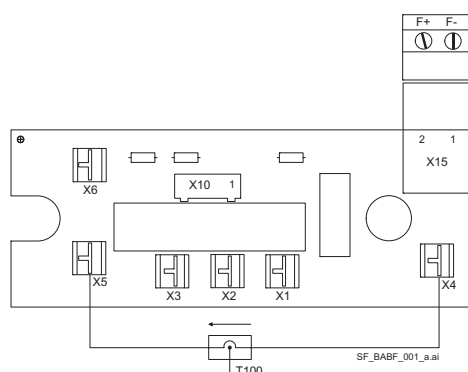

SDCS-BAB-F02 for module sizes H3 and H4:

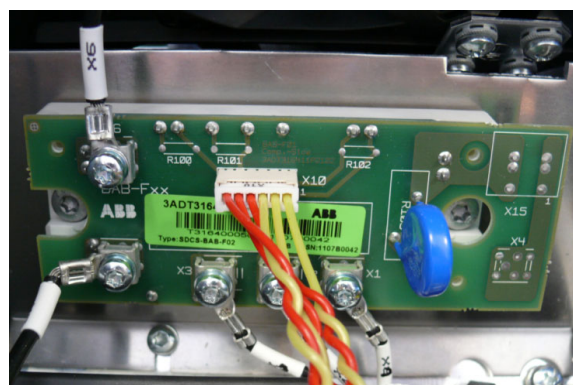
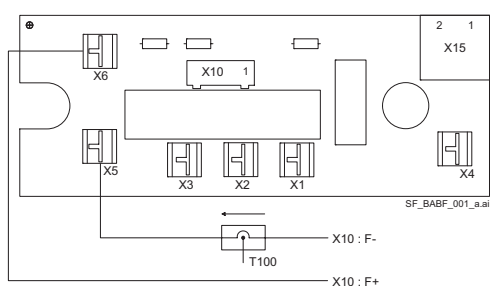

Location

The SDCS-BAB-F0x is located between the power part and the control board SDCS-CON-H01.

Functions

The SDCS-BAB-F0x is a three-phase half-controlled field exciter. The field exciter is directly supplied from the armature mains. Its firing pulses and snubbers are located on the SDCS-PIN-H01. For connection details see next pages.

Size	Converter type	Used type	Used fuses	T100 threads	I_F [A]
H1	DCS880-S01-0020 ... DCS880-S02-0025	SDCS-BAB-F01	F100 ... F102 on SDCS-PIN-H01 KTK 25 = 25 A	4 ①	0.3 ... 6
H1	DCS880-S01-0045 ... DCS880-S02-0100	SDCS-BAB-F01	F100 ... F102 on SDCS-PIN-H01 KTK 25 = 25 A	3 ①	1 ... 12
H2	DCS880-S01-0135 ... DCS880-S02-0300	SDCS-BAB-F01	F100 ... F102 on SDCS-PIN-H01 KTK 25 = 25 A	2 ①	1 ... 18
H3	DCS880-S01-0315 ... DCS880-S02-0520	SDCS-BAB-F02	F100 ... F102 on SDCS-PIN-H01 KTK 25 = 25 A	1 ①	2 ... 25
H4	DCS880-S01-0610 ... DCS880-S02-1000	SDCS-BAB-F02	F401 ... F403 in drive KTK 30 = 30 A	1 ①	2 ... 30

① Number of threads through the hole in the T100 (e.g. 3 threads equal 2 loops).

Circuit diagram

Typical armature circuit diagram for module sizes H1 and H2 using SDCS-PIN-H01 and SDCS-BAB-F01:

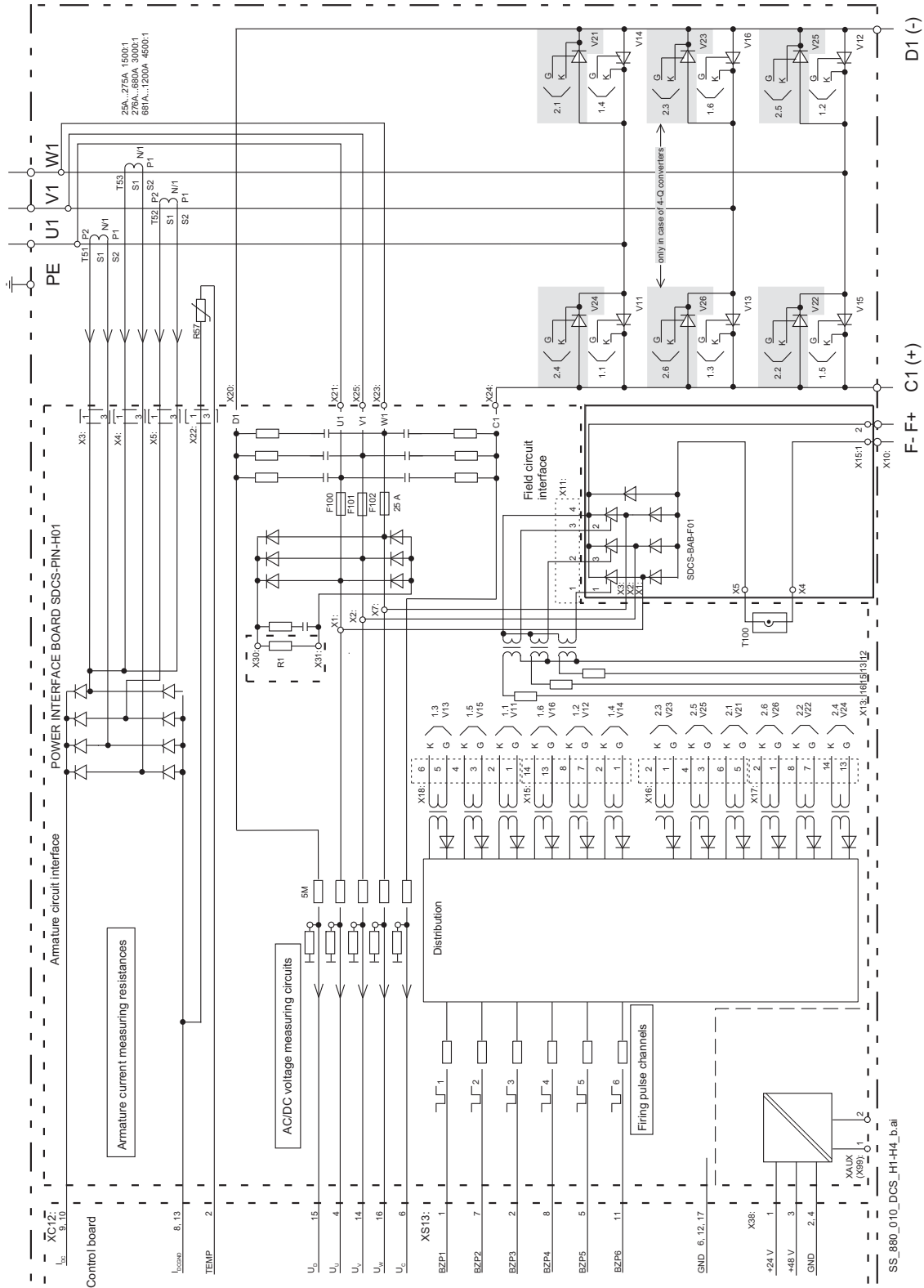

Typical armature circuit diagram for module sizes H3 and H4 using SDCS-PIN-H01 and SDCS-BAB-F02:

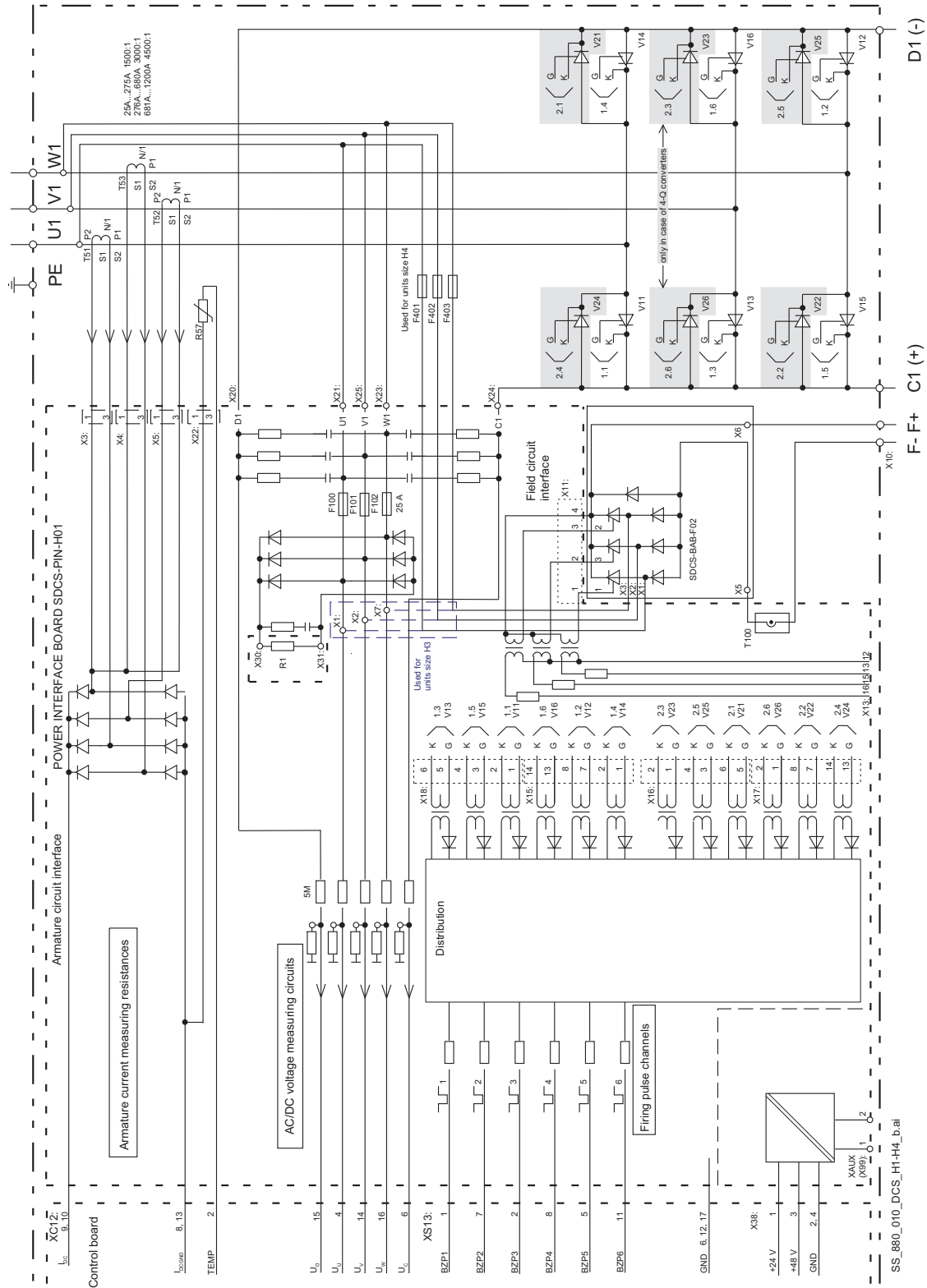

Typical armature circuit diagram for module size H5 using SDCS-PIN-H01:

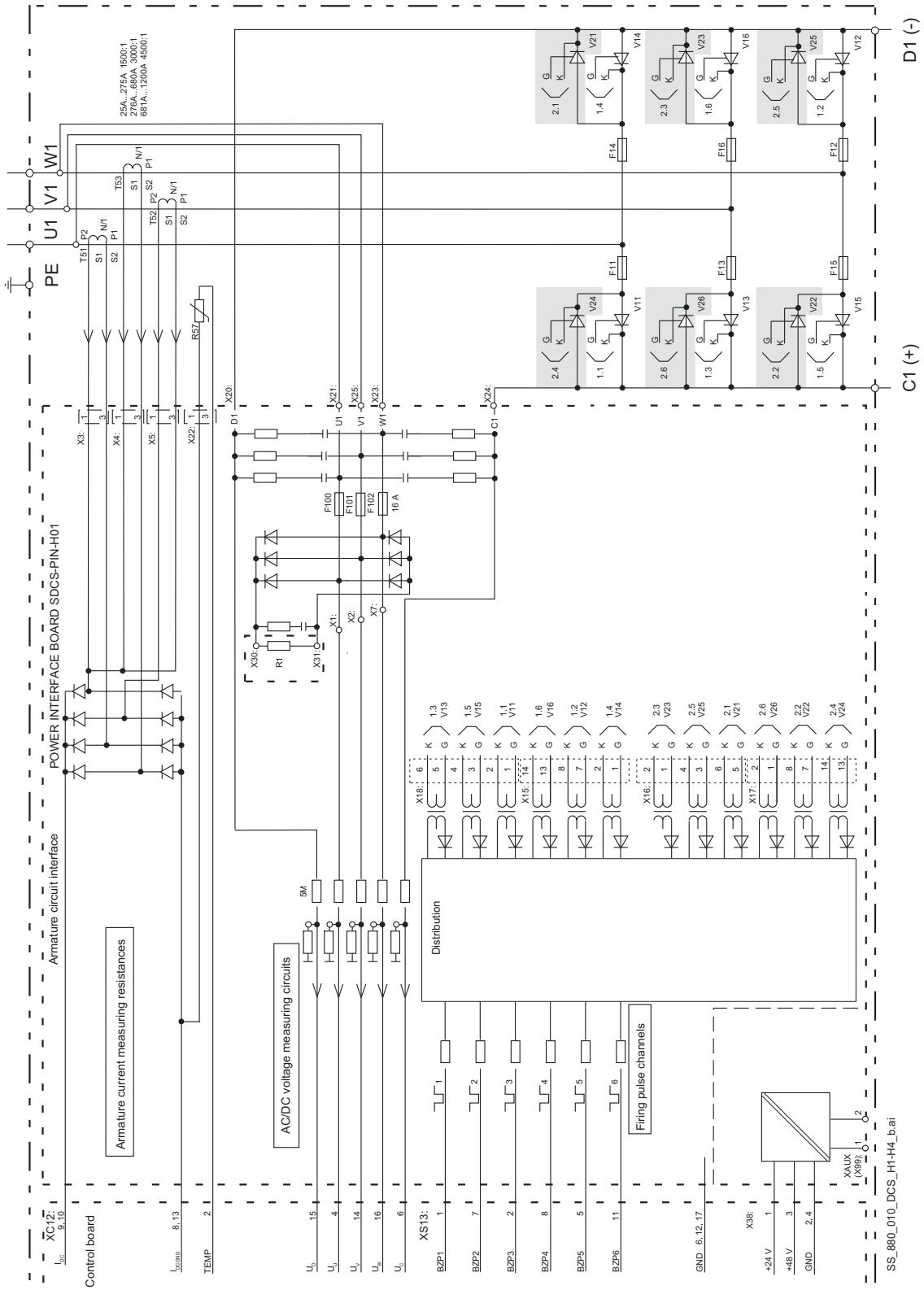

Measuring board SDCS-PIN-H51 (H6 ... H8)

The measuring board is equipped with inputs for current measurement via CTs, high ohmic voltage measurement and an input for a temperature sensor.

Following connectors are available:

- Four identical channels for current measurement on the mains side via CTs connected to X231 / X232, X241 / X242, X251 / X252 and X261 / X262.

The AC current is rectified by diodes on the measurement board.

The burden resistor is automatically scaled by the type code setting in the firmware for CT ratios of either 1:2500 or 1:4000.

- AC voltage and motor voltage are measured by four different types of inputs.

20 V_{AC} ... 100 V_{AC}: Voltage measurement via X15. For this remove the zero Ohm resistors R221 ... R225. This results in 1.2 MOhm inputs.

100 V_{AC} ... 525 V_{AC}: Voltage measurement via XU2, XV2, XW2, XC2 and XD2 (about 1 MOhm to ground).

526 V_{AC} ... 1000 V_{AC}: Voltage measurement via XU1, XV1, XW1, XC1 and XD1 (about 2 MOhm to ground).

100 V_{AC} ... 1200 V_{AC}: Galvanically isolated voltage measurement via X15. For this DC-DC transducer A92 and transformer T90 have to be used. X15 provides 27.4 kOhm inputs.

- X22 is used for the DCS880 NTC temperature sensor.

- XC12 connection to SDCS-CON-H01 (size H6) or SDCS-OPL-H01 (size H7, H8).

Settings of the SDCS-PIN-H51 for converter sizes H6 ... H8

Current coding

Size	H6				H7				H8					
Current transformer ratio	2500:1				2500:1				4000:1					
Rated current [A _{DC}] ①	900	1200	1500	2000	1900	2050	2500	3000	2050	2600	3300	4000	4800	5200
R101 ... R116	18 Ω	No cutting required. Automatic current coding via type code setting in the firmware.												
R118	68 Ω													
R119	120 Ω													
R120	249 Ω													
R121	560 Ω													

① Rated current see the name plate of the converter.

Voltage coding

Type code voltages (DD)	04 with +S185 05 with +S185	04 (400 V) 05 (525 V)	06 (600 V) 07 (690 V) 08 (800 V) 10 (990 V)	04 (400 V) 05 (525 V) 06 (600 V) 07 (690 V) 08 (800 V) 10 (990 V) 12 (1200 V)
Mains voltage	20 V _{AC} ... 100 V _{AC}	100 V _{AC} ... 525 V _{AC}	526 V _{AC} ... 1000 V _{AC}	100 V _{AC} ... 1200 V _{AC}
Used connectors	X15 with removed zero ohm resistors R221 ... R225 (cut out)	XU2 XV2 XW2 XC2 XD2	XU1 XV1 XW1 XC1 XD1	X15 with DC-DC transducer A92 and transformer T90
Parameter settings 95.28 Set: Drive AC voltage scaling	120 V	0 V	0 V	0 V

Switches

Leave switch J1 on separated (default).

Location of the SDCS-CON-H01

Size H6:

- The board is located inside the module.

Module sizes H7 and H8 consist of a control unit and a power unit:

- The board is located inside the power unit.

Layout of the SDCS-PIN-H51

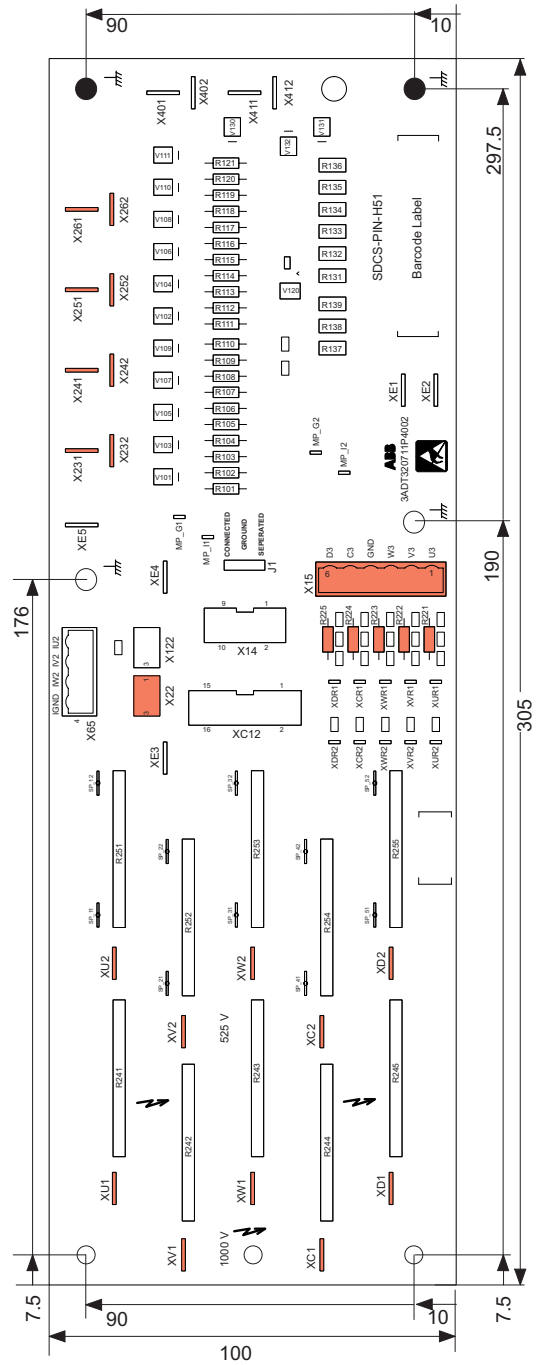
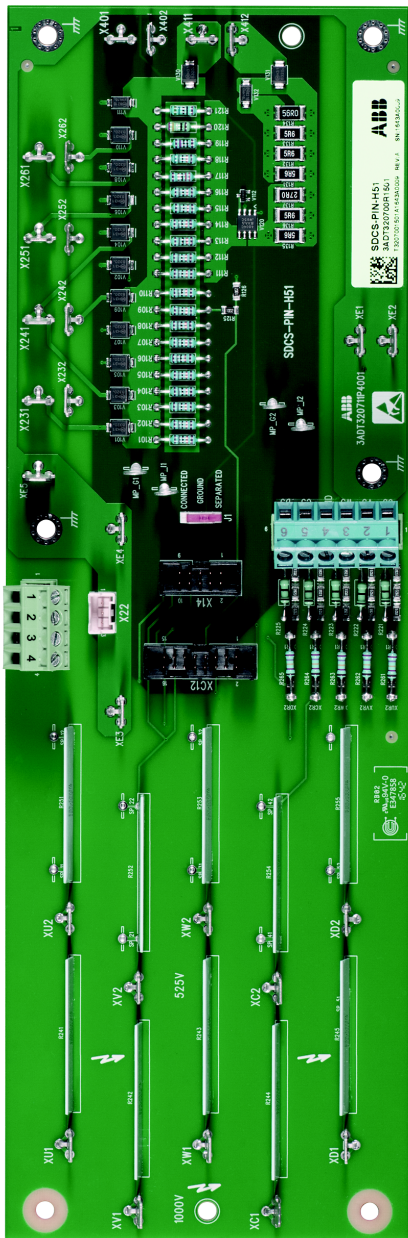

BL_PIN-H51_001_b.ai

Firing pulse transformer board SDCS-PIN-H41 (H6 ... H8)

The interface to the power part of the converter modules size H6 ... H8 from 900 A up to 5200 A consists of one or two firing pulse transformer boards SDCS-PIN-H41.

Single bridge converters (2-Q) are equipped with one board. Converters with 2 anti-parallel bridges (4-Q) require two boards.

Location of the SDCS-PIN-H41

Size H6:

- The board is located inside the converter module.

Module sizes H7 and H8 consist of a control unit and a power unit:

- The board is located inside the power unit.

Layout of the SDCS-PIN-H41

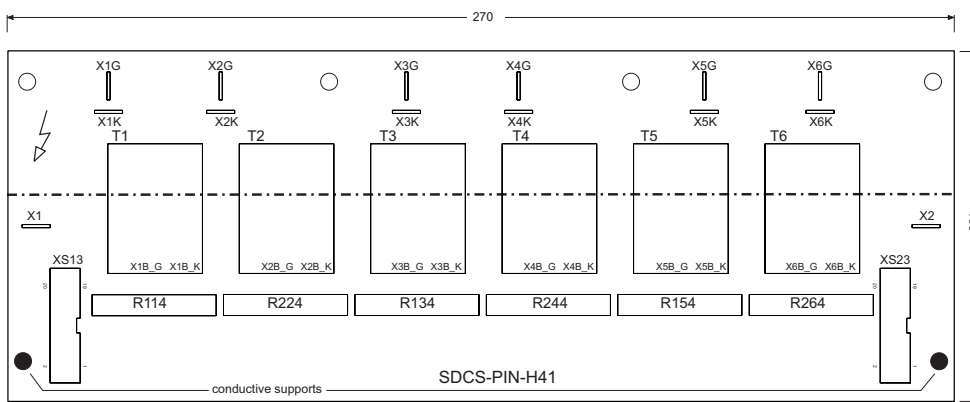

The board consists of six firing pulse transformers with amplifiers.

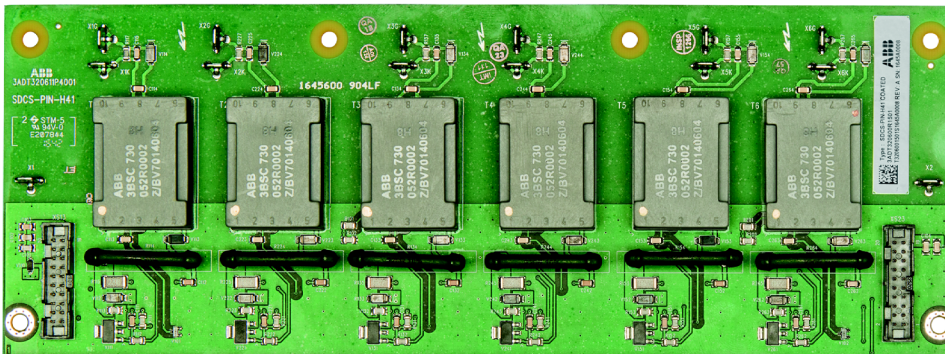

Optical power link board SDCS-OPL-H01 (H7, H8)

Module sizes H7 and H8 consist of a control unit and a power unit. The board provides the interface between control unit and power unit using fiber optic cables.

Following connectors are available

Fiber optic connectors V1, V2 connect the SDCS-CON-H01 via SDCS-DSL-H1x for control.

Fiber optic connectors V11, V12 connect the SDCS-CON-H01 via SDCD-DSL-H1x for Safe Torque Off (STO).

Maximum length of the plastic optic fiber cable is 5 m.

Connector X4 is a connection point for a scope to measure the armature current directly over the burden resistor.

X4 Current measurement

1	IACT	Connection point for a scope. Scaling see 13.80 Scaling of fixed current output.
2	-	-
3	-	-
4	GND1	Common ground (connected to frame)

SA_880_013_OPL_b.ai





Connector XC12 connects the SDCS-PIN-H51.

Connector XS13 connects the SDCS-PIN-H41.

Connector X38 connects the SDCS-POW-H01.

Connector XSMC (X96) connects the mains connector and must be used. XSMC on the control unit is not allowed due to Safe Torque Off (STO).

XSMC (X96) Mains contactor

1	MCCOM		250 V _{AC} / 30 V _{DC}	Fixed output for the mains contactor
2	MCNO		2 A	Fixed output for the mains contactor
3	STOCOM		250 V _{AC} / 30 V _{DC}	Fixed output for safe torque off (STO) zero current monitor
4	STONO		2 A	Fixed output for safe torque off (STO) zero current monitor

SA_880_013_OPL_a.ai

XSMC (X96): Mains contactor

MCCOM	Fixed output for the mains contactor
MCNO	250 V _{AC} / 30 V _{DC} ; 2 A Maximum wire size 2.5 mm ² Varistor protected
STOCOM	Fixed output for safe torque off (STO) zero current monitor
STONO	250 V _{AC} / 30 V _{DC} ; 2 A Maximum wire size 2.5 mm ² Varistor protected
	Mains contactor ON command: 06.24.b07 Current controller status word 1

Location of the SDCS-OPL-H01

The board is located inside the power unit.

Layout of the SDCS-OPL-H01

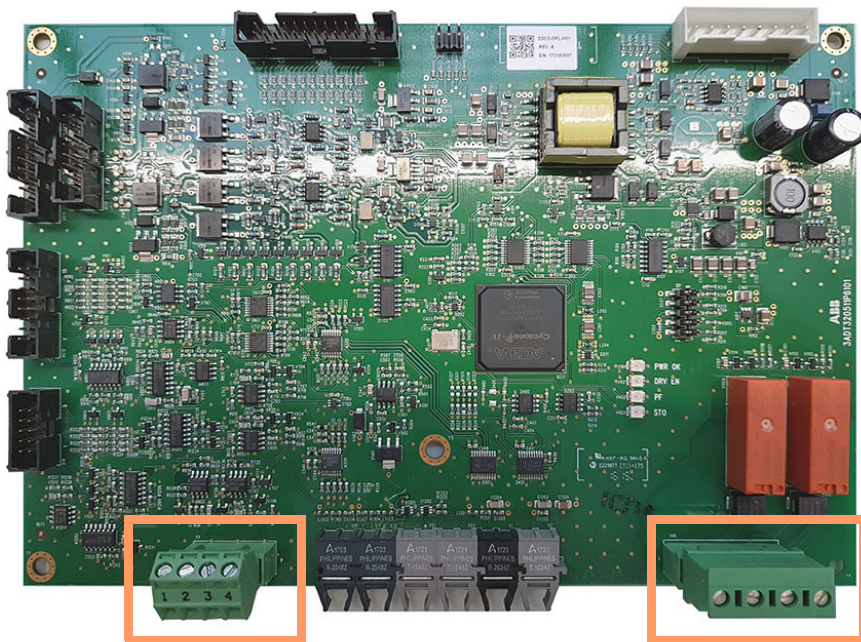
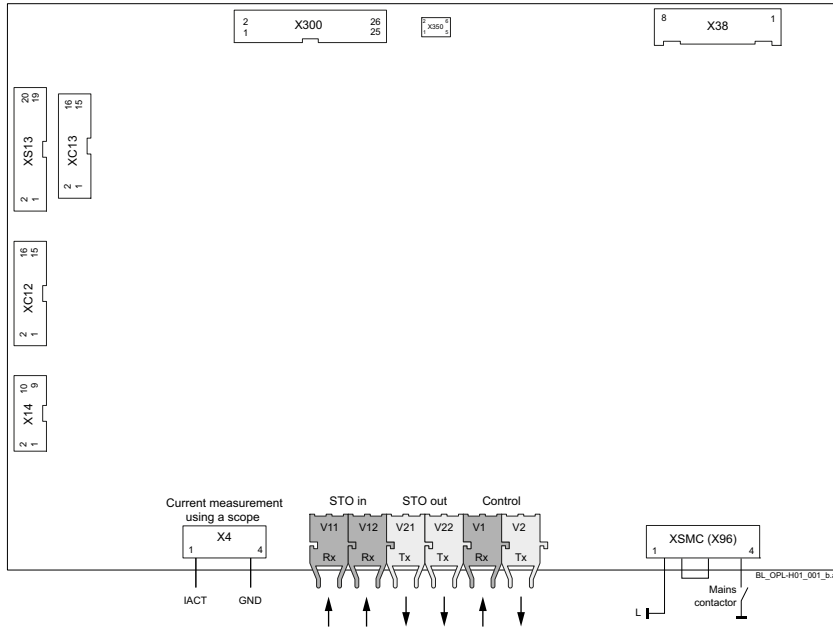

Current measurement via scope

Mains contactor

Connection between firing and control board for H6 ... H8

2-Q, size H6

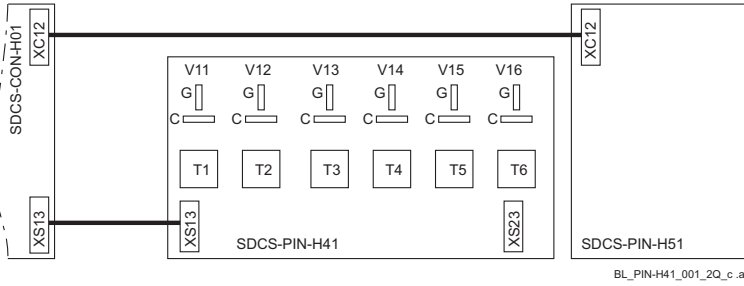

4-Q, size H6

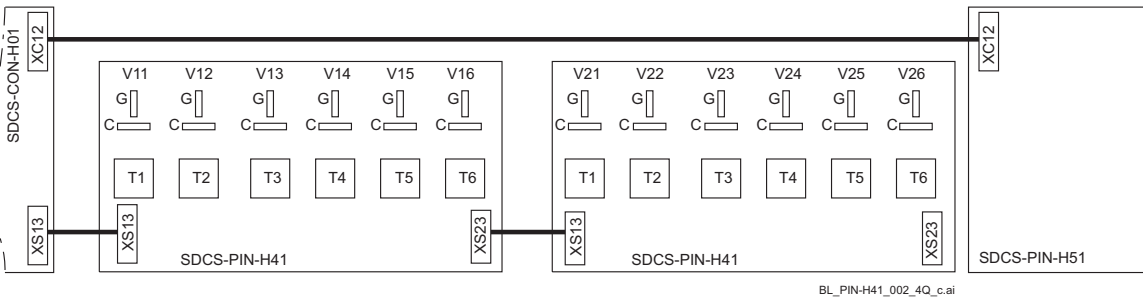

2-Q, sizes H7 and H8

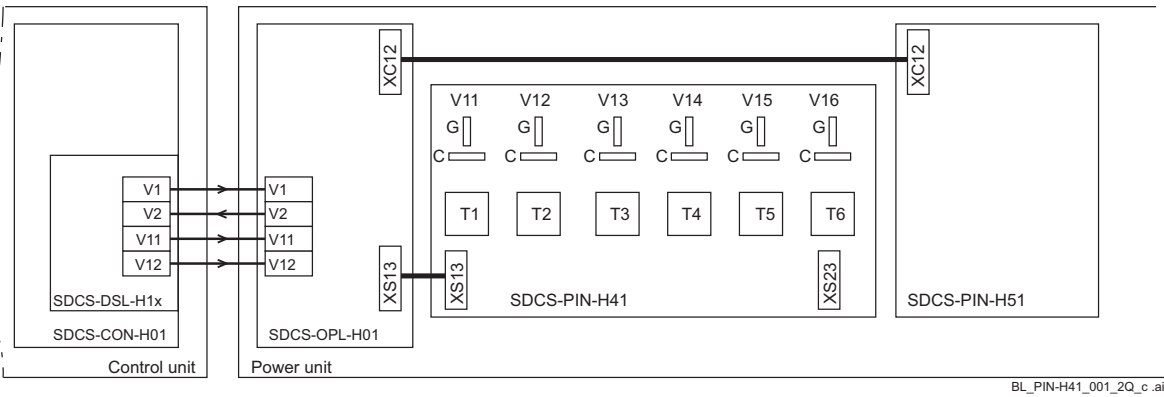

4-Q, sizes H7 and H8

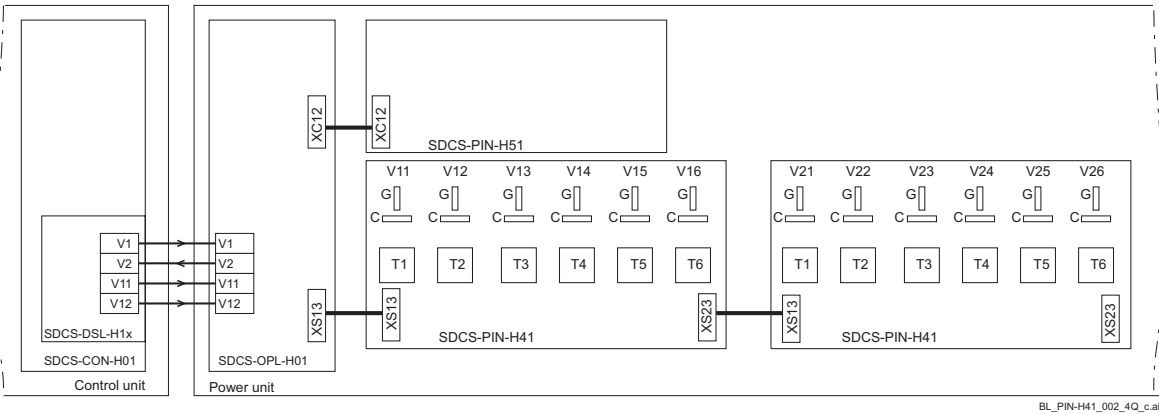

Technical data

Circuit diagram

Typical armature circuit diagram for module size H6 with SDCS-PIN-H51 and SDCS-PIN-H41:

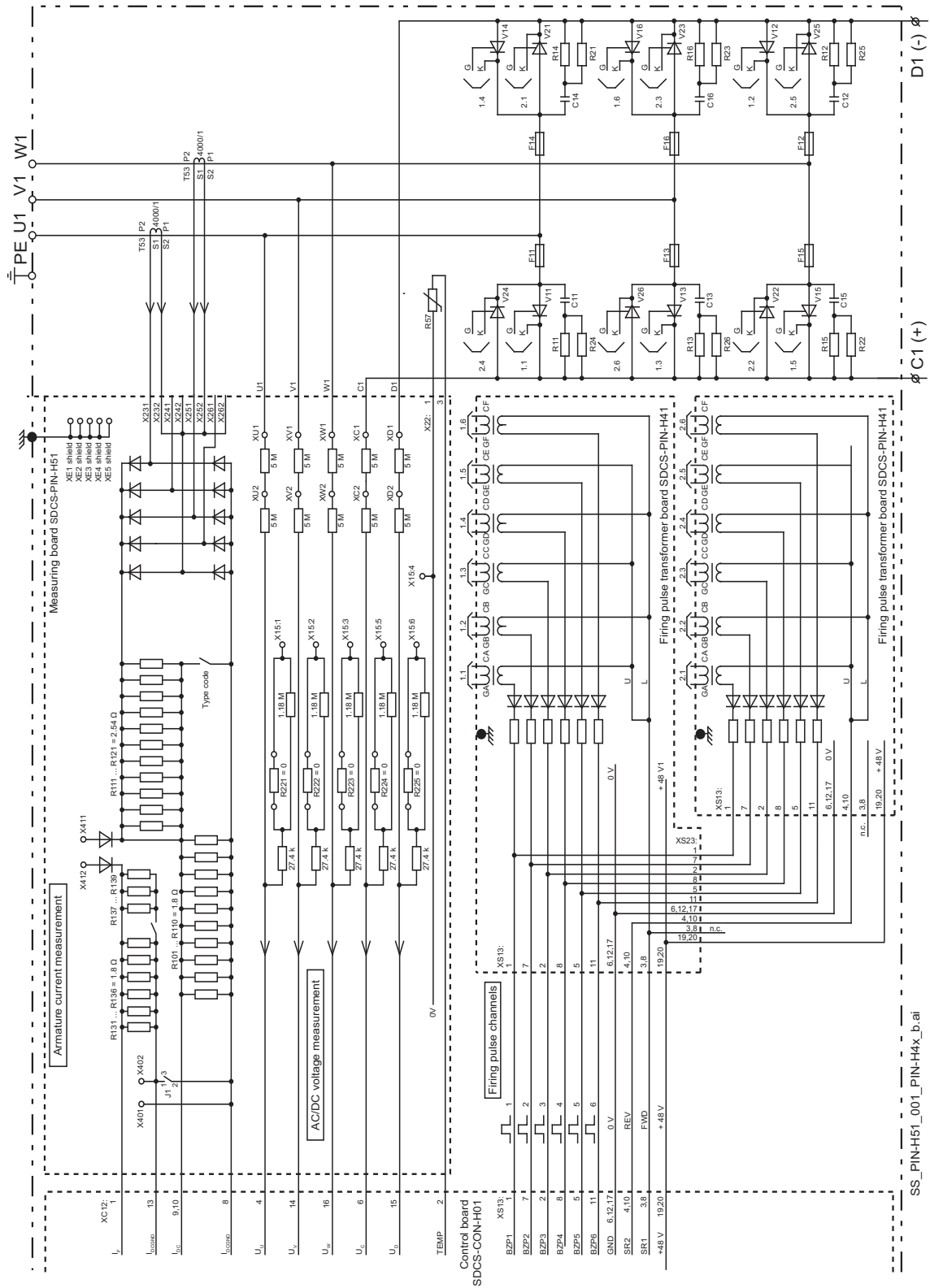

Typical armature circuit diagram for module sizes H7 and H8 with SDCS-PIN-H51 and SDCS-PIN-H41:

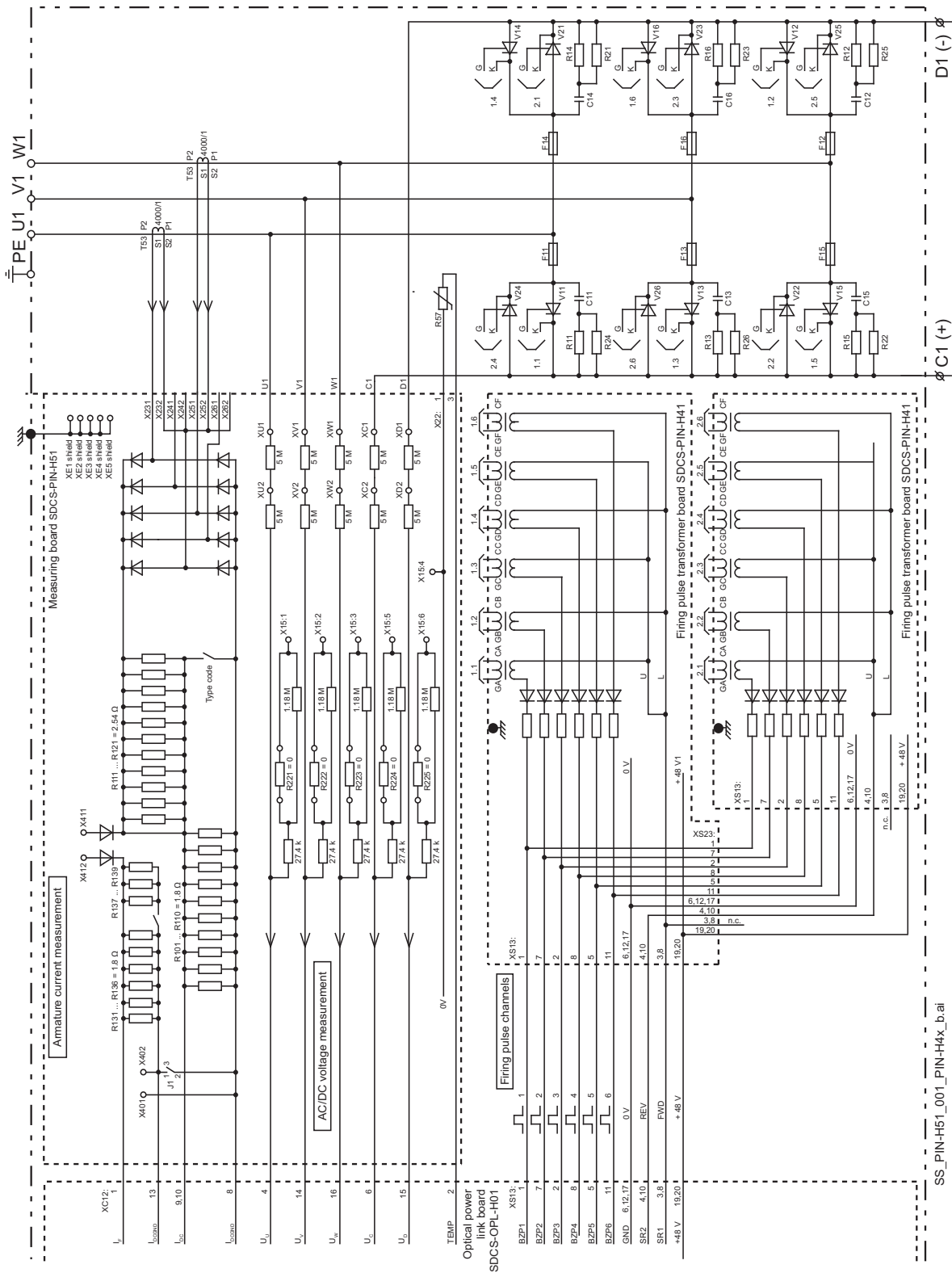

Galvanic isolation - T90, A92, F11, F90

The Galvanic isolation is an option for converters size H6 ... H8 and rated voltages ≤ 1000 V.

For converters with a rated AC voltage of > 1000 V or 12-pulse serial $> 2 \times 500$ V galvanic isolation must be used.

It is used to replace the high-ohmic voltage measurement and gives the advantage of a total isolation between power part and drive electronics.

The transformer T90 and the DC-DC transducer A92 are located outside the converter module. The internal AC and DC voltage measurement channels are removed and connected to T90 and A92.

DC-DC transducer A92

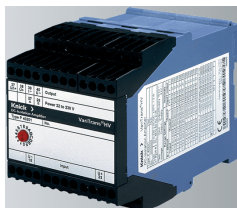

P42000D3-0111 (3ADN260008P0001) or
P42001D3 (3ADV050096P0007)

Transformer T90

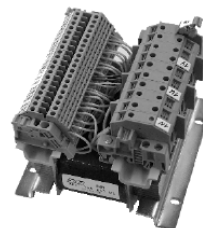

3ADT745047P0001

SDCS-PIN-H51



Hardware and firmware settings:

Voltage coding						
Size	H6 / H7 / H8					
Con. nom. voltage [V] U1 [V _{AC}] ①	Y = 4 (400 V) Y = 5 (500 V)	Y = 6 (600 V)	Y = 7 (690 V)	Y = 8 (800 V)	Y = 10 (1000 V)	Y = 12 (1200 V)
Rated mains voltage [V _{AC}]	100 ... 525	270 ... 600	315 ... 690	360 ... 800	450 ... 1000	540 ... 1200
Voltage measurement scaled by type code or parameter (95.28)	500	600	690	800	1000	1200
Measuring board	SDCS-PIN-H01 use connector X15					

Galvanic isolation						
Fuse F11	1500 V, 5 A					
DC-DC transducer A92 (1)	P42000D3-0111 (3ADN260008P0001)					
Switch position R _G	0 (675 V)	1 (810 V)	2 (945 V)	3 (1080 V)	5 (1350 V)	6 (1620 V)
DC-DC transducer A92 (2)	P42001D3 (3ADV050096P0007)					
Switch position R _G	-	-	-	-	A (1400 V)	B (1600 V)
Fuse F90	1000 V, 10 A					
Transformer T90	3ADT745047P0001					
Secondary Terminals	2U1 2V1 2W1 2N	2U2 2V2 2W2 2N	2U3 2V3 2W3 2N	2U4 2V4 2W4 2N	2U5 2V5 2W5 2N	2U6 2V6 2W6 2N

① Rated voltage see the name plate of the converter.

For 12-pulse configurations consult the [DCS880 12-pulse manual](#).

Typical armature circuit diagram for module sizes H6 ... H8 with SDCS-PIN-H51, SDCS-PIN-H41 and galvanic isolation:

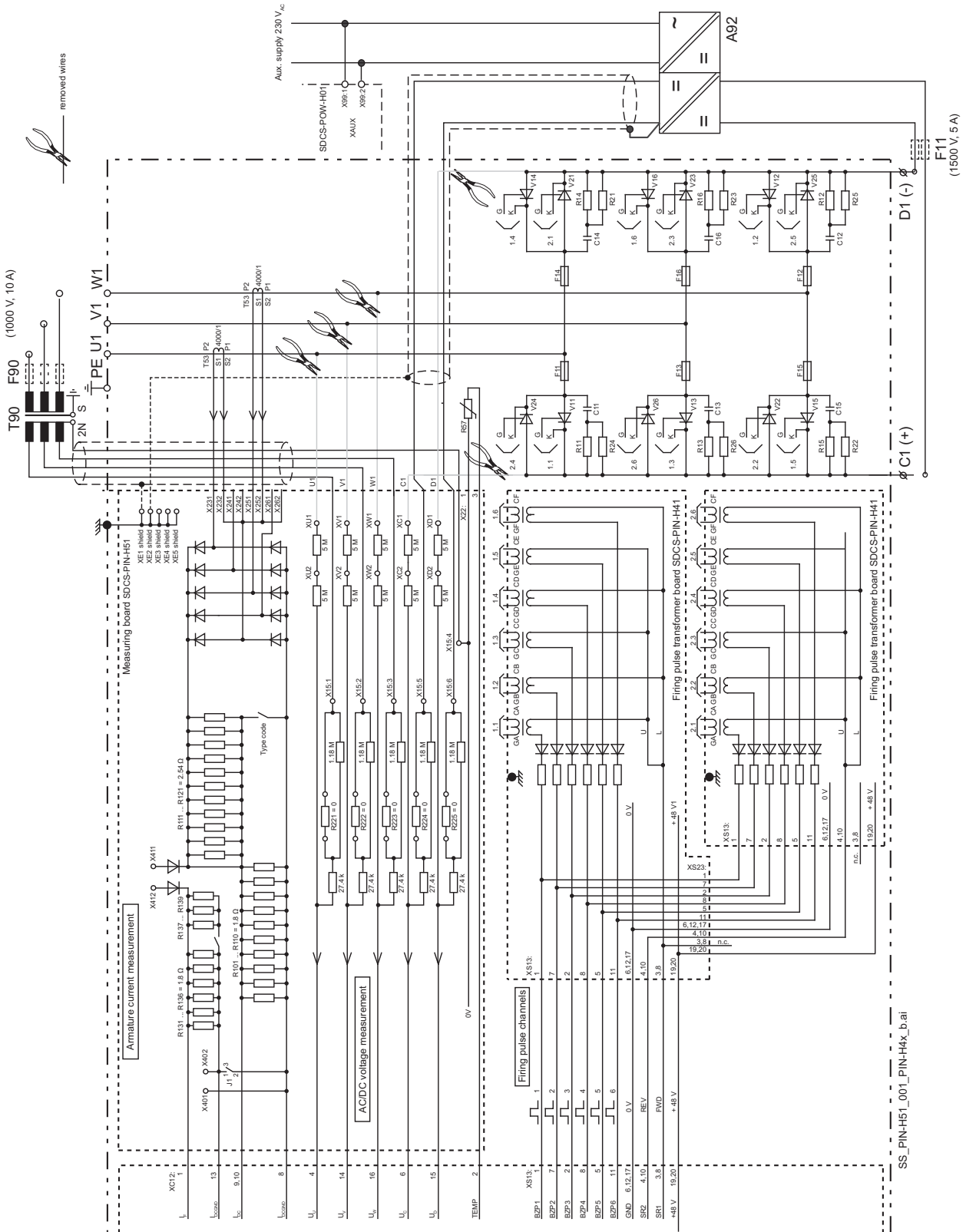

DC-DC transducer A92 (1)

Principle circuit diagram of the DC-DC transducer A92 (1)

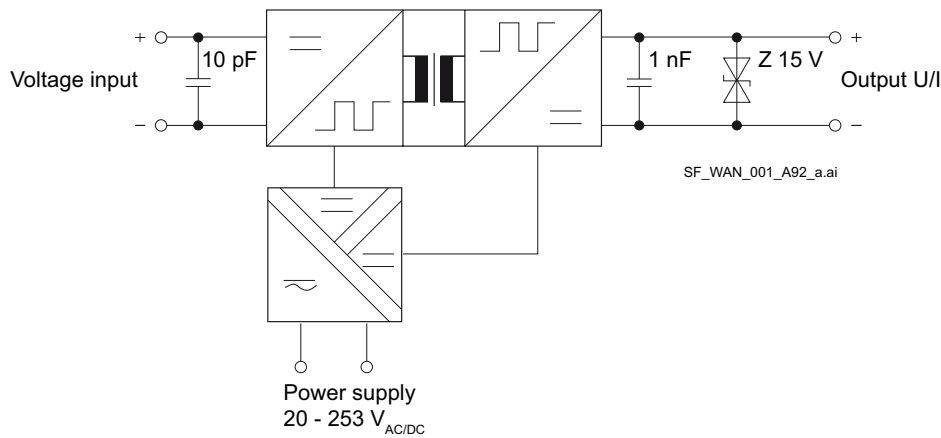

Data

Selectable voltage gains	675	810	945	1080	1350	1620	V _{DC}
Switch position	0	1	2	3	5	6	-

- Output voltage: 20 mA; ±10 V; 4 ... 20 mA
- Auxiliary power: 20 ... 253 V_{AC/DC}; 50/60 Hz; 3 W
- Clearance in air: Auxiliary power to Output: > 13 mm
Input / Output to Auxiliary power: > 14 mm
- Insulation voltage: 2200 V
- Insulation test voltage: 10 kV_{AC}
- Ambient temperature range: -10 ... +70°C
- Weight: appr. 500 g

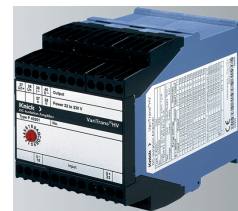

(P42000D3-0111)

The voltage gain and frequency response is especially designed for DCS880 converters.

Dimensions in mm

Terminal assignments:

- 15 Voltage input -
- 23 Voltage input + (≤ 3600 V)
- 27 Power supply AC/DC
- 28 Power supply AC/DC
- 37 Current output +
- 38 Voltage output +
- 39 Current output -
- 40 Voltage output -

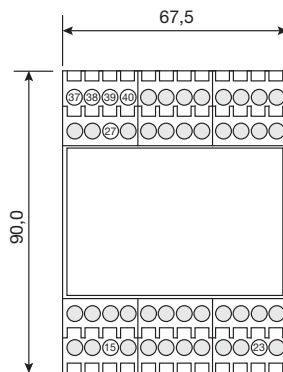

BE_KLE_001_a.ai

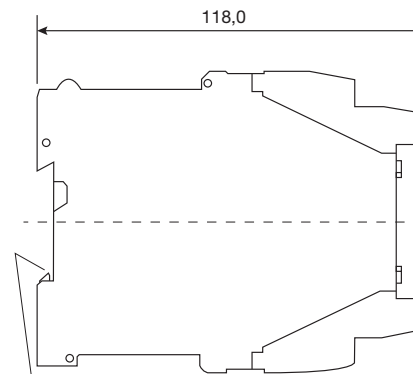

Snap-on mounting for 35 mm top-hat rail
DIN EN 50 022

Transformer T90

Principle diagram of the transformer T90

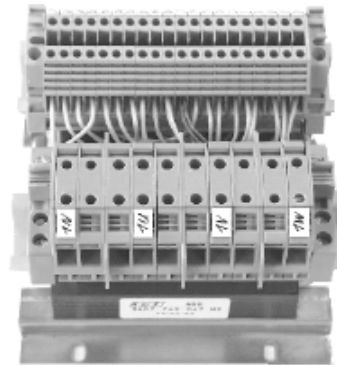
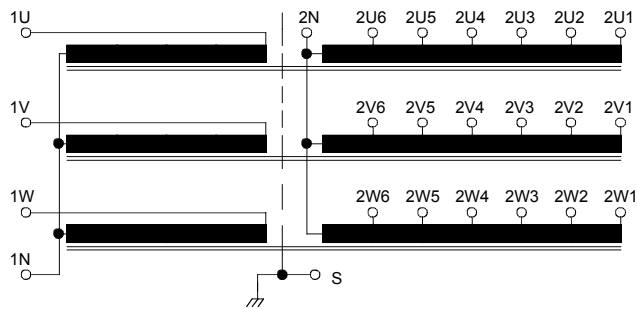

(3ADT745047)

Data

Selectable transfer ratios U_{prim} :	500, 600, 690, 800, 1000, 1200 V _{AC} rms
Output voltage:	7.3 V _{AC} rms
Insulation voltage:	1200 V
Isolation test voltage:	3500 V
Ambient temperature range:	- 10 ... + 70 °C
Weight:	2.1 kg

Dimensions in mm

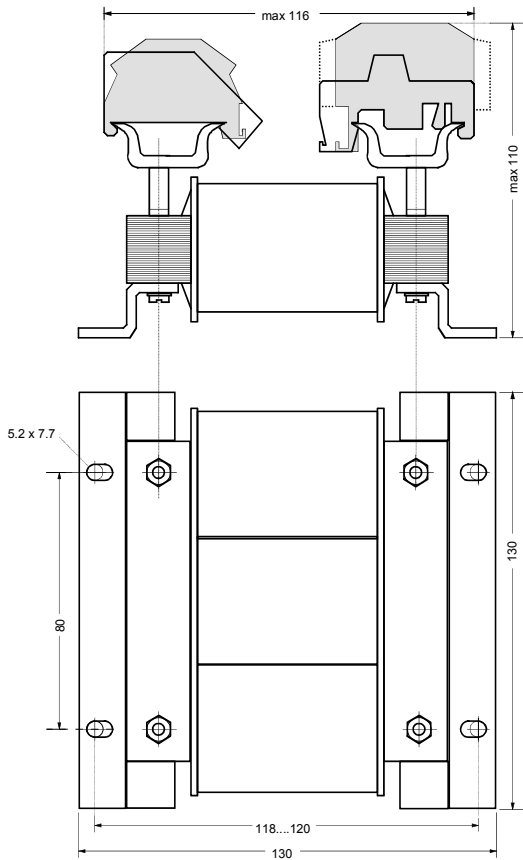

Note:

The terminals on the primary side of the transformer are a special lug terminal design.

Handling hints:

First turn the screw counter-clockwise to the end stop, then swing out the shrouding cover. Put in the cable lug, swing in the shrouding cover and fasten the connection by turning the screw clockwise.

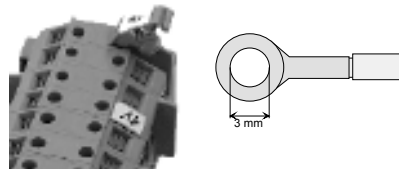

Dimensions and weights

See the dimensional drawings of the DCS880 below. The dimensions are in millimeters.

Size	h * w * d [mm]	h * w * d [inch]	weight [kg]	weight [lbs]
H1	370*270*215	14.56*10.63*8.46	11	25
H2	370*270*271	14.56*10.63*10.67	16	36
H3	460*270*317	18.11*10.63*12.48	25	56
H4	645*270*352	25.39*10.63*13.86	38	84
H5	750*270*372	29.53*10.63*14.65	55	122
H6	944*510*410	37.17*20.08*16.14	110	243
H7	1750*460*410	68.90*18.11*16.14	180	397
H8	1750*760*570	68.90*29.92*22.44	315	695

Size H1

DCS880-S01-0020
DCS880-S01-0045
DCS880-S01-0065
DCS880-S01-0090

DCS880-S02-0025
DCS880-S02-0050
DCS880-S02-0075
DCS880-S02-0100

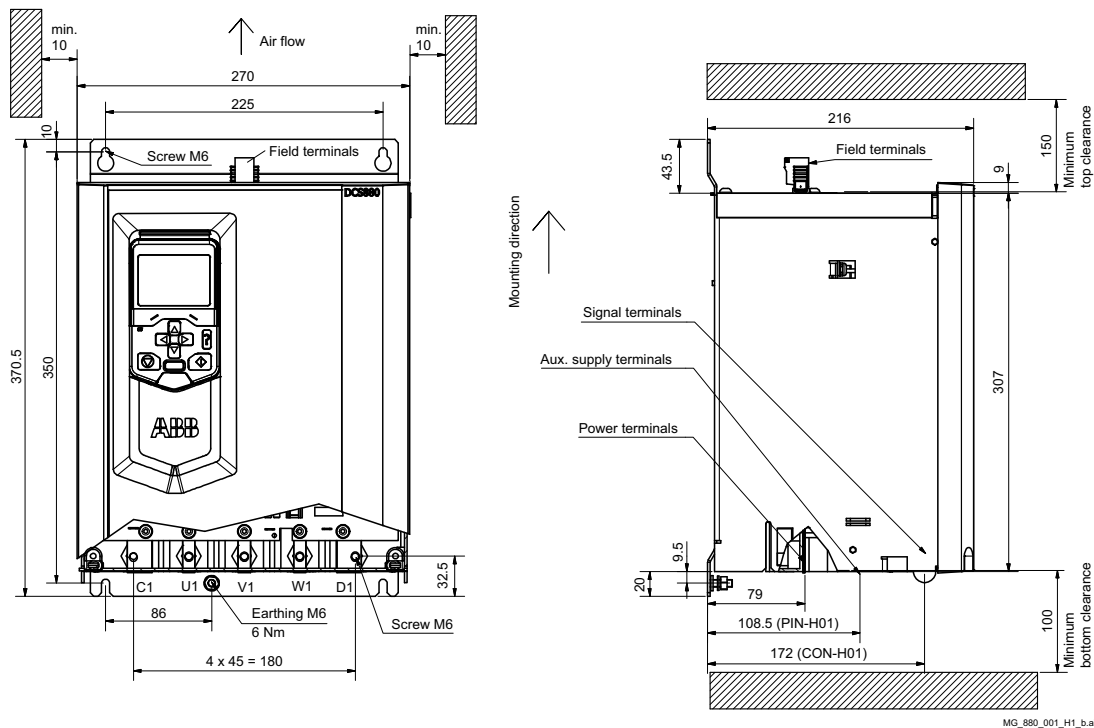

Size H2

DCS880-S01-0135
 DCS880-S01-0180
 DCS880-S01-0225
 DCS880-S01-0270

DCS880-S02-0150
 DCS880-S02-0200
 DCS880-S02-0250
 DCS880-S02-0300

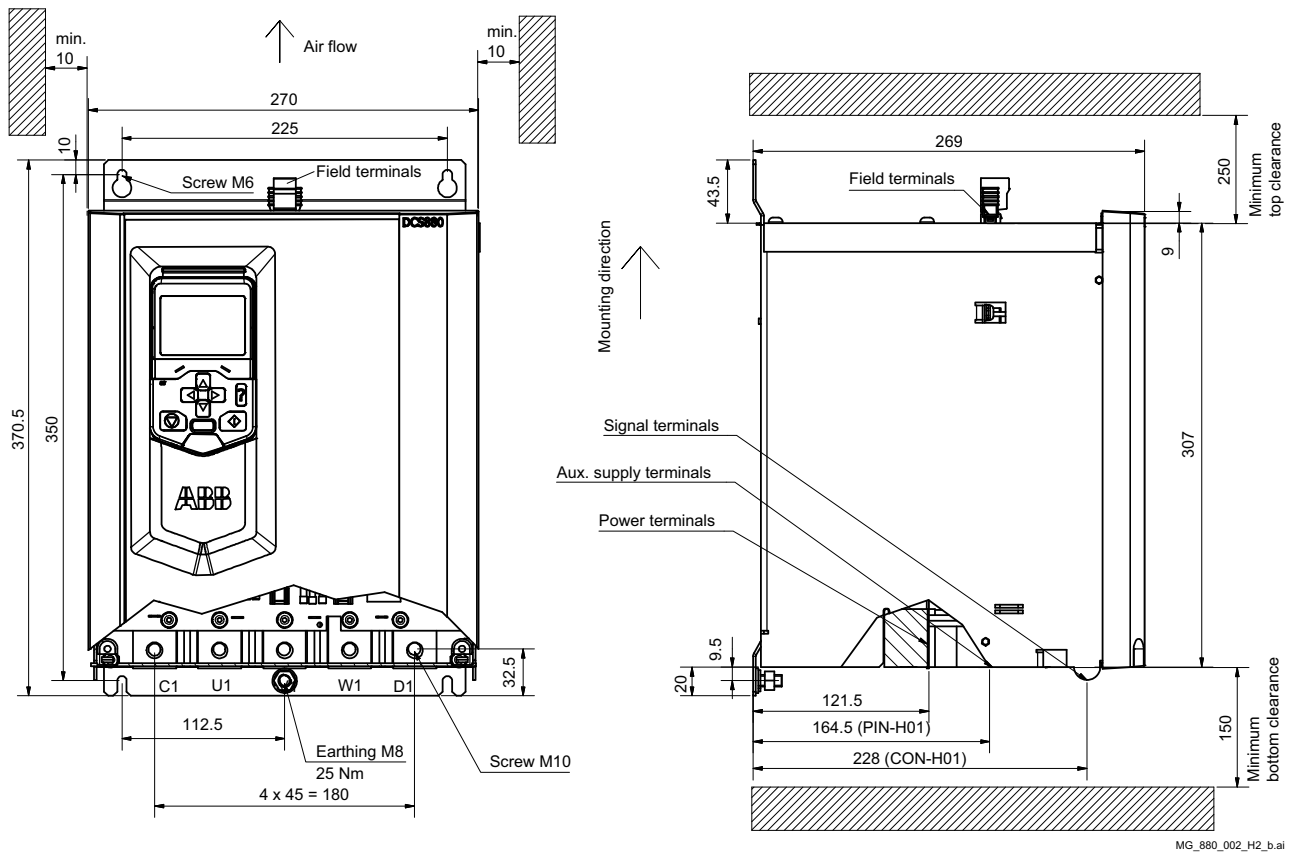

MG_880_002_H2_b.ai

Size H3

DCS880-S01-0315
 DCS880-S01-0405
 DCS880-S01-0470

DCS880-S02-0350
 DCS880-S02-0450
 DCS880-S02-0520

600 V Units

DCS880-S01-0290
 DCS880-S02-0320

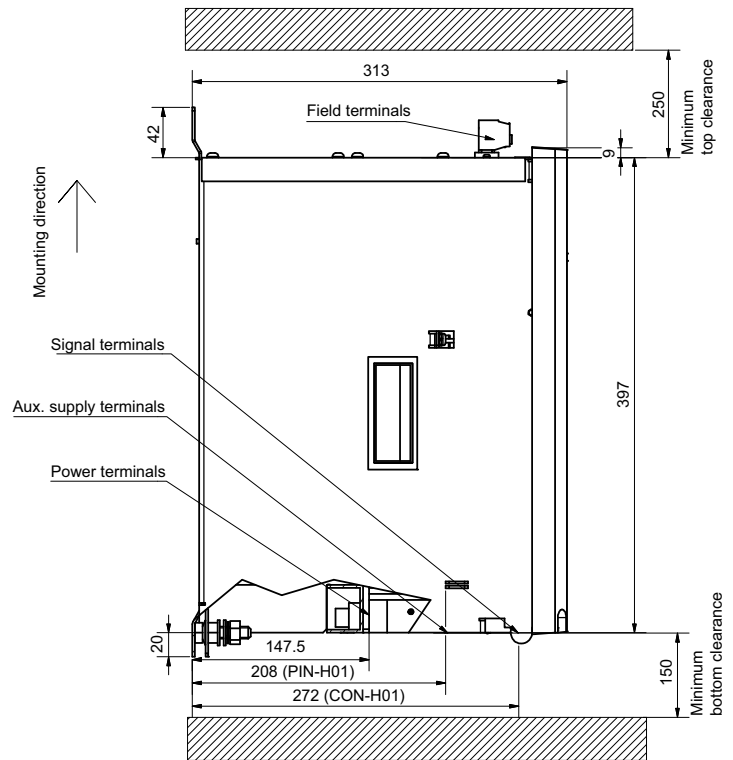
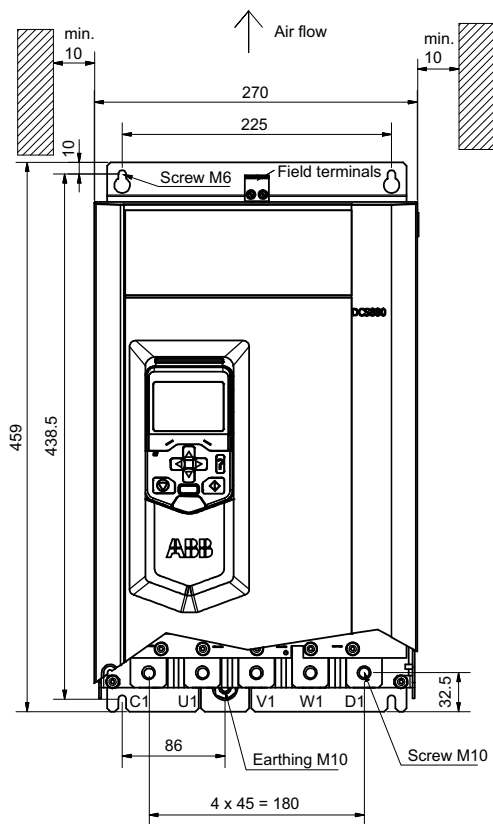

MG_880_003_H3_b.ai

Size H4

DCS880-S01-0610
 DCS880-S01-0740
 DCS880-S01-0900

DCS880-S02-0680
 DCS880-S02-0820
 DCS880-S02-1000

600 V Units

DCS880-S01-0590
 DCS880-S02-0650

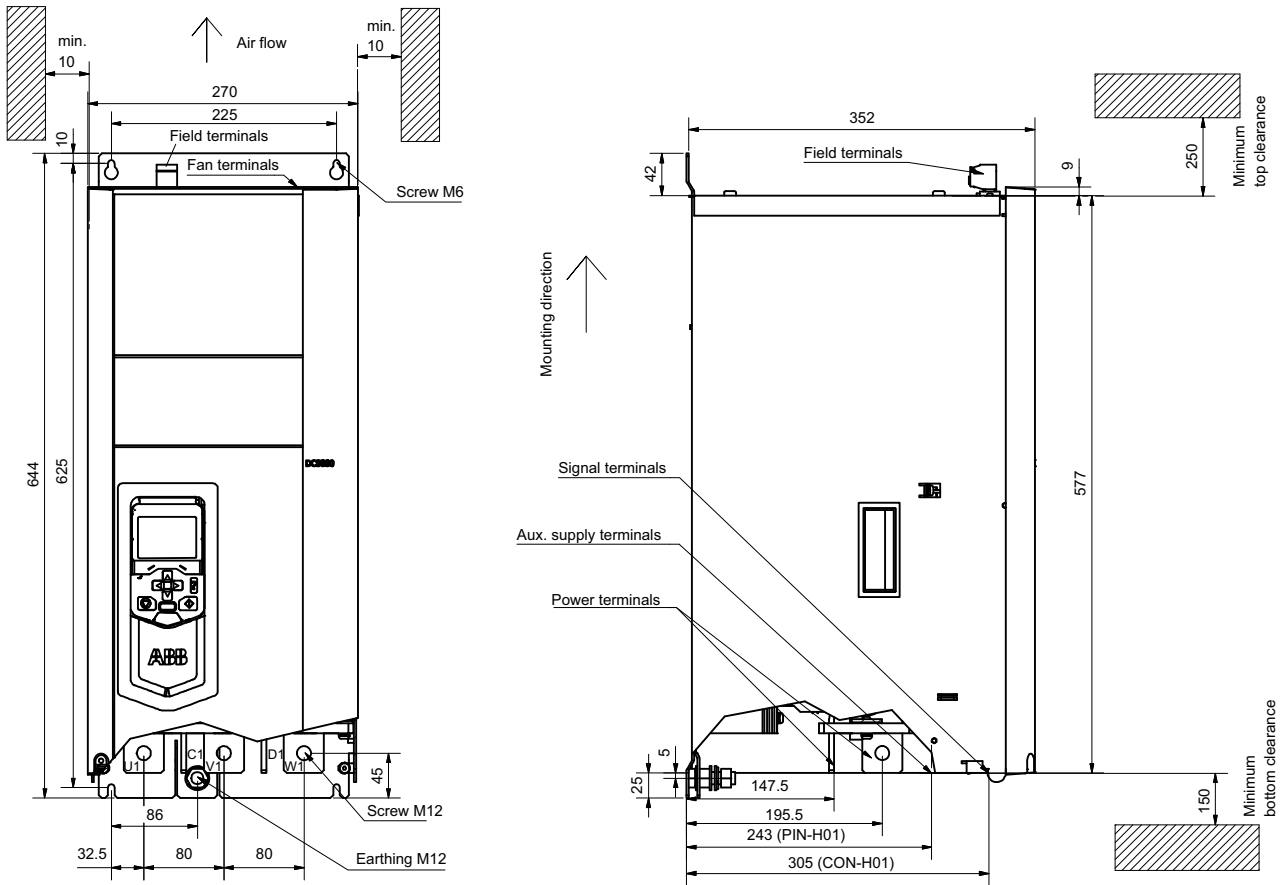

MG_880_004_H4_a.ai

Size H5

DCS880-S01-1190

DCS880-S02-1190

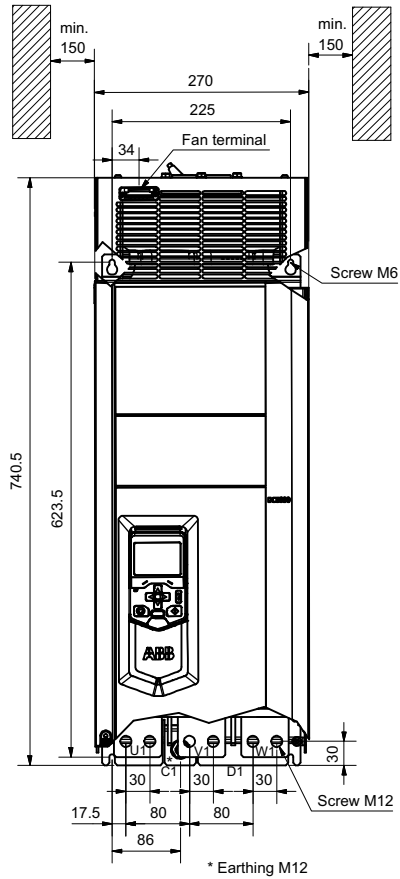

Mounting direction ↑

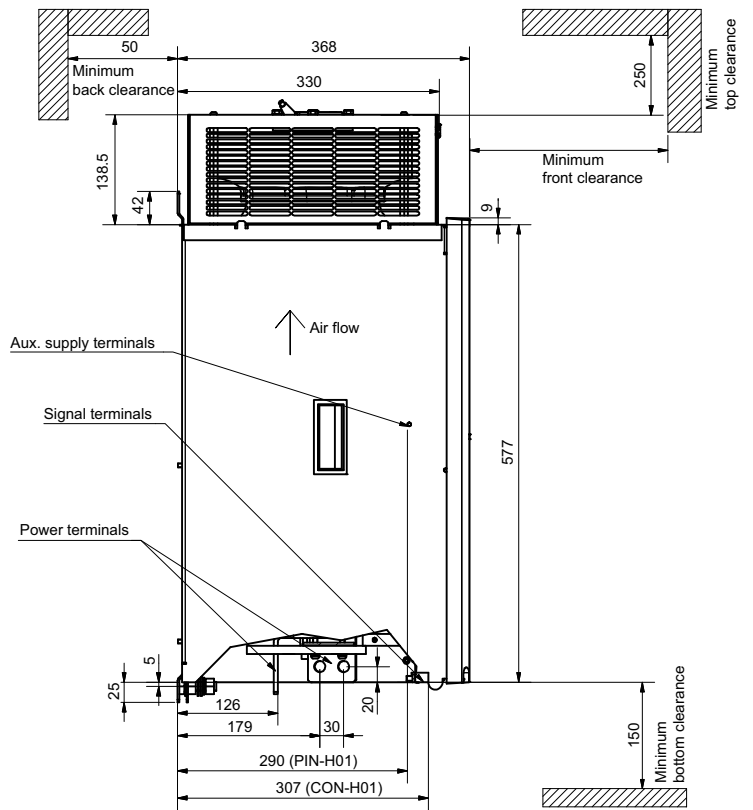

MG_880_005_H5_b.ai

Size H6

DCS880-S0B-0900
 DCS880-S0B-1200
 DCS880-S0B-1500
 DCS880-S0B-2000

Busbars in mm:
 DC: 80 x 10
 AC: 60 x 5

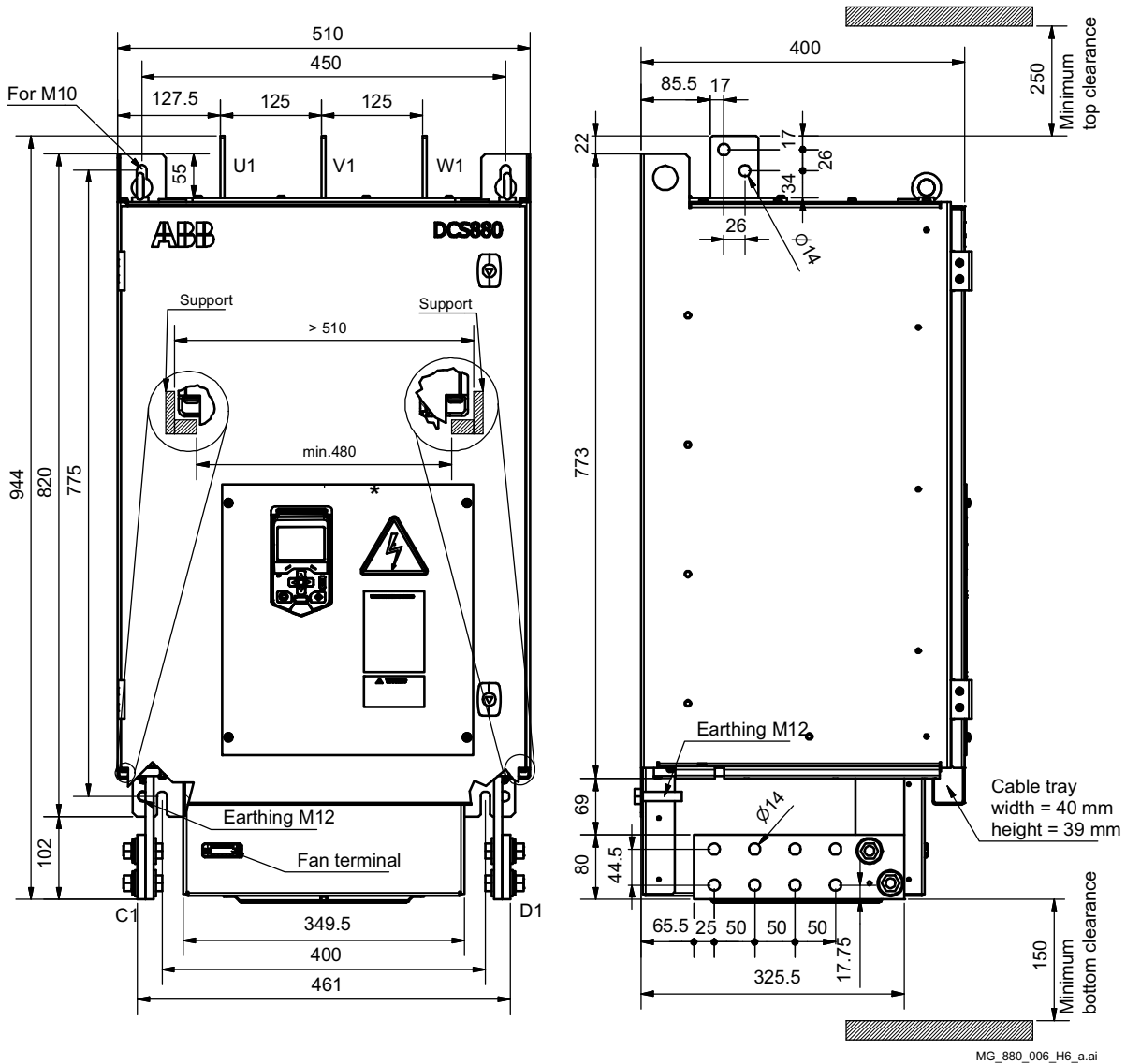

Mounting the module size H6 inside a cabinet

Two supports should be mounted inside the cabinet in such a way, that they can carry the module's weight. The minimum distance between the supports should not be less than 480 mm because of electrical clearance (DC busbars).

An L-shape support as indicated will allow to place the converter temporarily close to the front end of the support (weight still taken by a lifting device) and then push it back to the back plate of the cabinet. The upper and lower holes in the back plate of the converter should be used to fix the converter in that position.

Dimensions and weights

Size H7 (+P906)

DCS880-S0b-1900
DCS880-S0b-2050
DCS880-S0b-2500
DCS880-S0b-3000
With external control unit
(+P906)

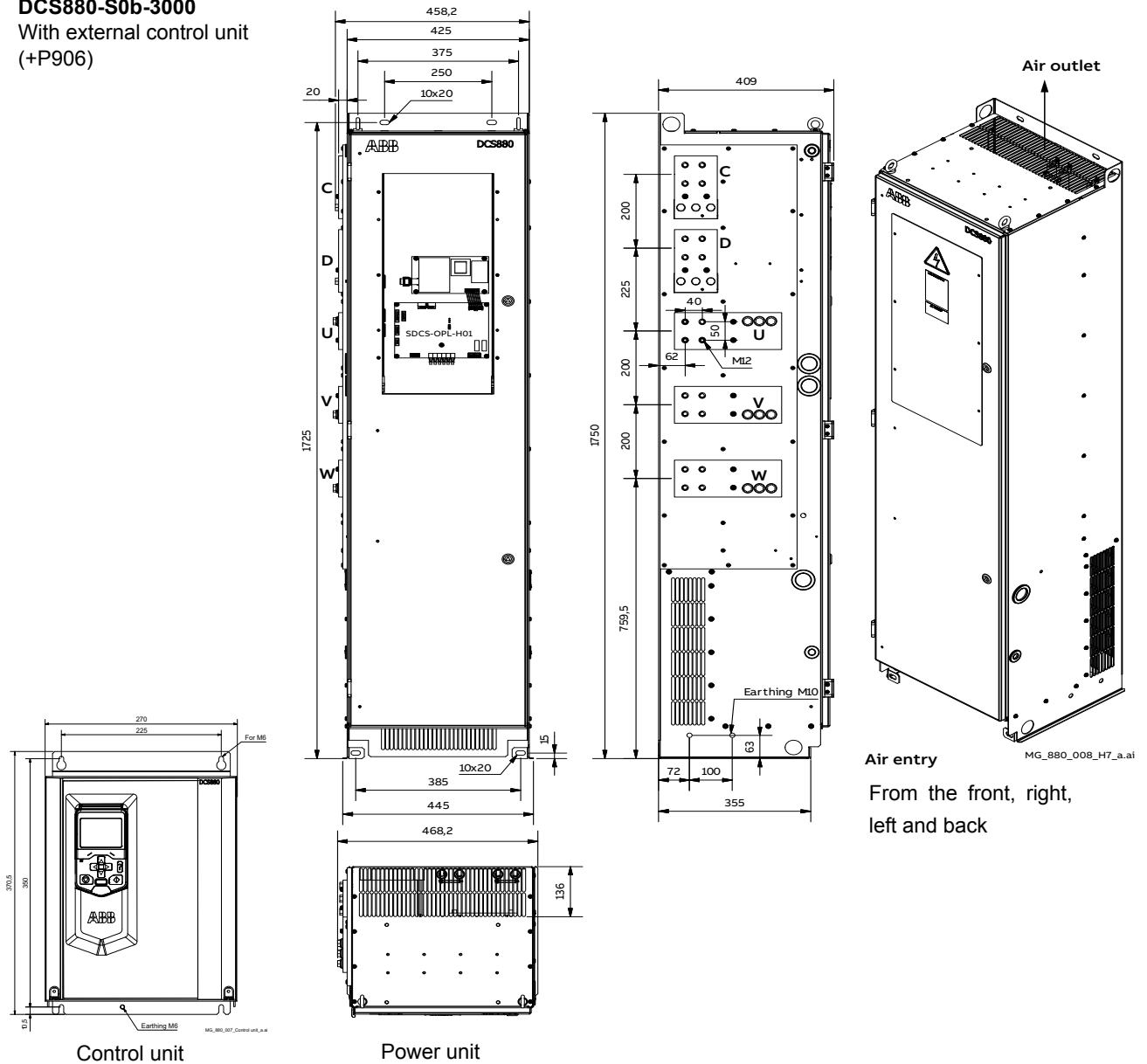

Size H8 lefthand (+P906)

DCS880-S0b-4800-0dL
DCS880-S0b-5200-0dL
With external control unit
(+P906)

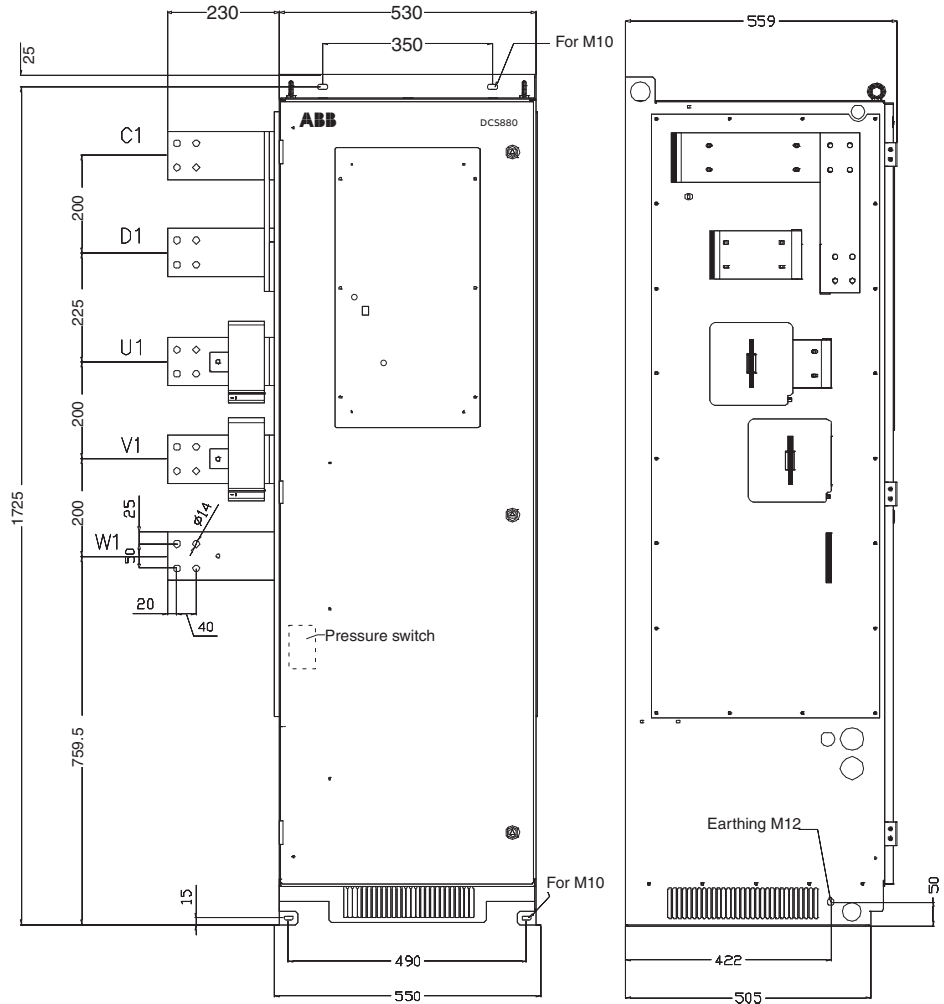

MG_800_007_D7_a.ai

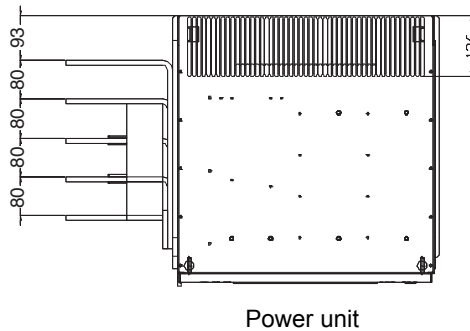
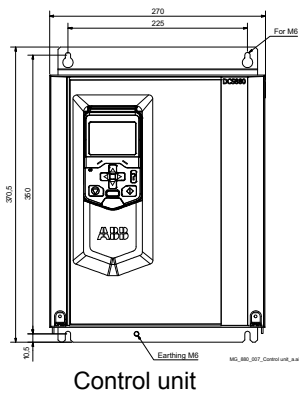

Busbars in mm:
AC and DC: 100 x 10

Size H8 righthand (+P906)

DCS880-S0b-4800-0dR
DCS880-S0b-5200-0dR
With external control unit
(+P906)

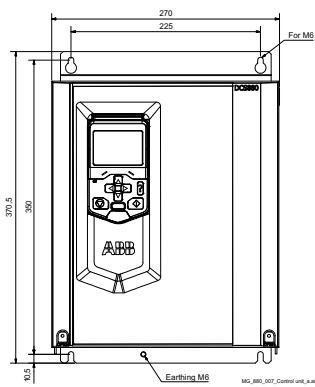

Control unit

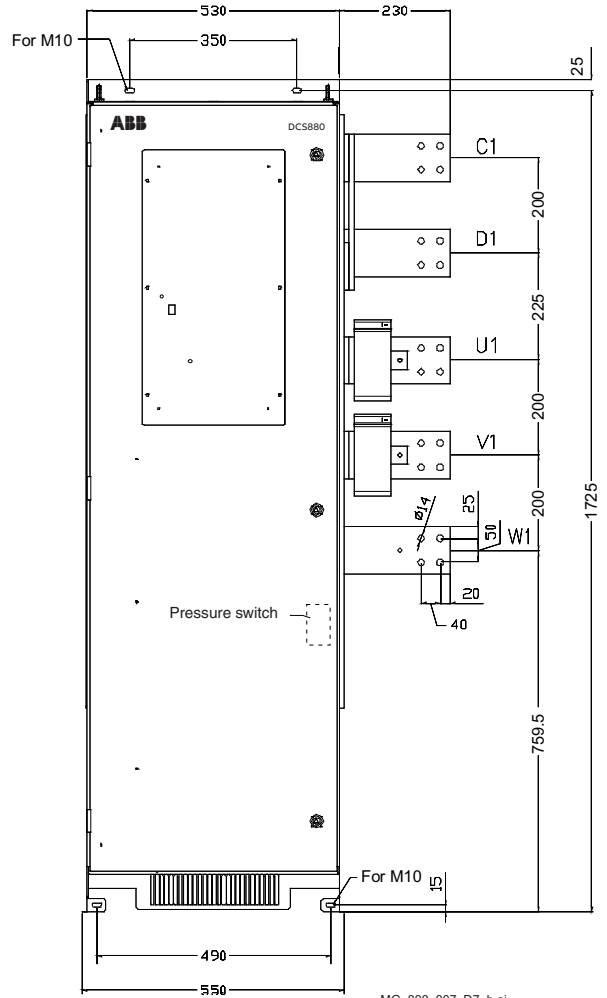
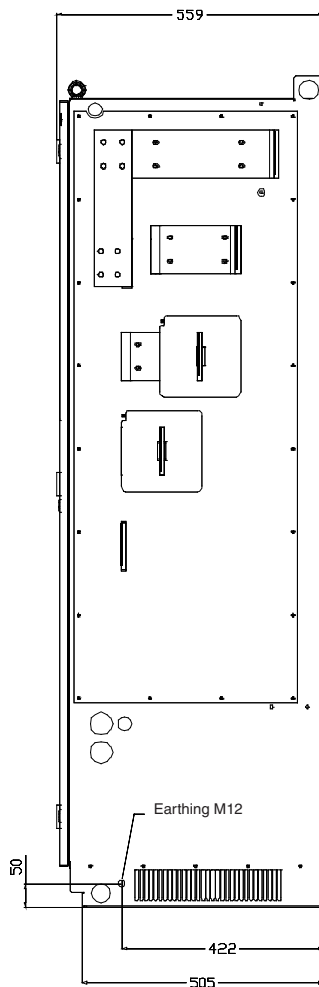

Busbars in mm:
AC and DC: 100 x 10

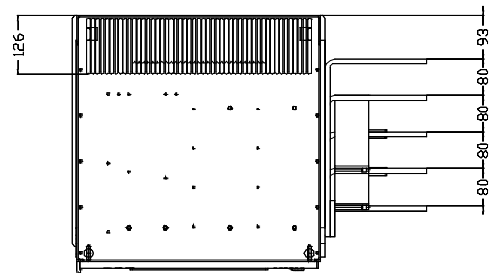

Power unit

Branch fuses installed inside converter sizes H5 ... H8

Size	Converter type	Fuse type	Fuse Size
	400 V / 500 V (IEC) / 525 V (UL)		
H5	DCS880-S0b-1190-04/05	UR 900 A / 690 V	2
H6	DCS880-S0b-1200-04/05	UR 800 A / 660 V	5
H6	DCS880-S0b-1500-04/05	UR 1250 A / 660 V	5
H6	DCS880-S0b-2000-04/05	UR 1600 A / 660 V	5
H7	DCS880-S0b-2050-05	UR 1500 A / 660 V	5
H7	DCS880-S0b-2500-04/05	UR 900 A / 660 V ①	5
H7	DCS880-S0b-3000-04/05	UR 1250 A / 660 V ①	5
H8	DCS880-S0b-3300-04/05	UR 2500 A / 660 V	7
H8	DCS880-S0b-4000-04/05	UR 3000 A / 660 V	7
H8	DCS880-S0b-5200-04/05	UR 3500 A / 690 V	7
	600 V / 690 V		
H6	DCS880-S0b-0900-06/07	UR 630 A / 1250 V	6
H6	DCS880-S0b-1500-06/07	UR 1100 A / 1250 V	6
H6	DCS880-S01-2000-06/07	UR 1400 A / 1100 V	6
H7	DCS880-S0b-2050-06/07	UR 700 A / 1250 V ①	6
H7	DCS880-S0b-2500-06/07	UR 1000 A / 1250 V ①	6
H7	DCS880-S0b-3000-06/07	UR 1100 A / 1250 V ①	6
H8	DCS880-S0b-3300-06/07	UR 2500 A / 1000 V	8
H8	DCS880-S0b-4000-06/07	UR 3000 A / 1000 V	8
H8	DCS880-S0b-4800-06/07	UR 3000 A / 1000 V	8
	800 V		
H7	DCS880-S0b-1900-08	UR 630 A / 1250 V ①	6
H7	DCS880-S0b-2500-08	UR 1000 A / 1250 V ①	6
H7	DCS880-S0b-3000-08	UR 1100 A / 1250 V ①	6
H8	DCS880-S0b-3300-08	UR 2500 A / 1000 V	8
H8	DCS880-S0b-4000-08	UR 3000 A / 1000 V	8
H8	DCS880-S0b-4800-08	UR 3000 A / 1000 V	8
	1000 V		
H8	DCS880-S0b-2050-10	UR 1800 A / 1250 V	9
H8	DCS880-S0b-2600-10	UR 1800 A / 1250 V	9
H8	DCS880-S0b-3300-10	UR 2500 A / 1250 V	9
H8	DCS880-S0b-4000-10	UR 2500 A / 1250 V	9
	1200 V		
H8	Data on request	-	-

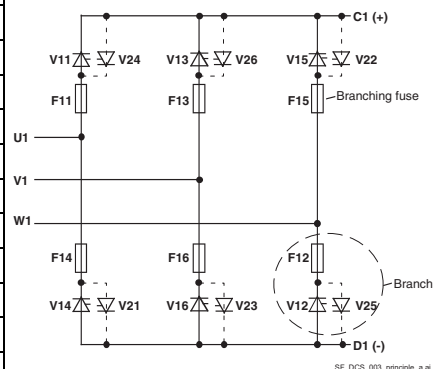

① Two fuses per thyristor (12 fuses per bridge).

Size 2

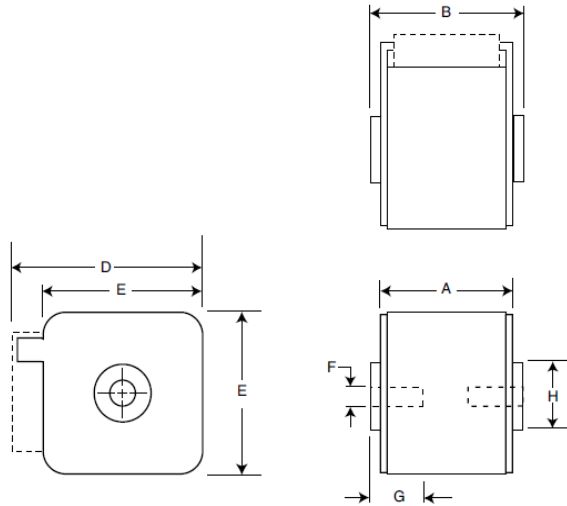

Size	A [mm]	B [mm]	D [mm]	E [mm]	F	G [mm]	H
2	50	51	77	61	M10	10	M24

Size 5, 6

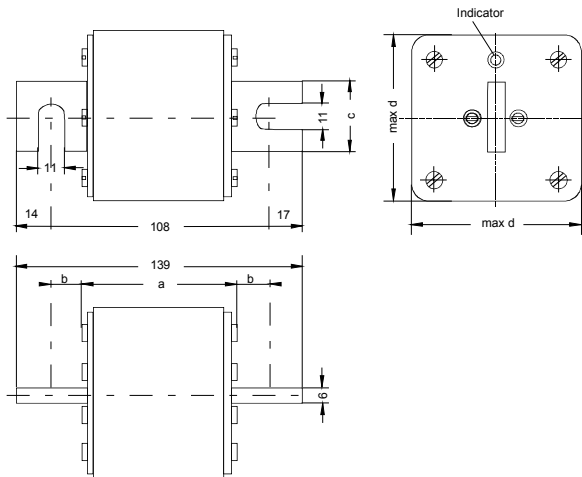

Size	a [mm]	b [mm]	c [mm]	d [mm]
5	50	29	30	76
6	80	14	30	76

Size 7 ... 9

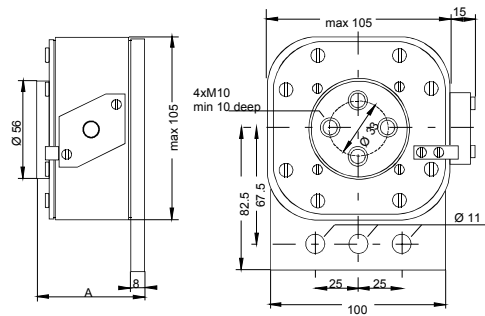

Size	A [mm]
7	62
8	90
9	105

Note:
The given dimensions may be exceeded in some cases. Please take them only for information.

Accessories

DCF803-0016, FEX-425-Int and DCF803-0035

The field exciters DCF803-0016, FEX-425-Int and DCF803-0035 are half controlled 3-phase converters. All field exciters are based on the same control board SDCS-FEX-4. The board is equipped with its own synchronization and current control. The current measurement circuit is automatically scaled depending on the rated field current of the motor. The field exciter is fully controlled and monitored by the armature converter via drive-to-drive communication.

The field exciter is prepared to operate as 3-phase as well as single-phase converter. For single-phase operation connect terminals U and W.

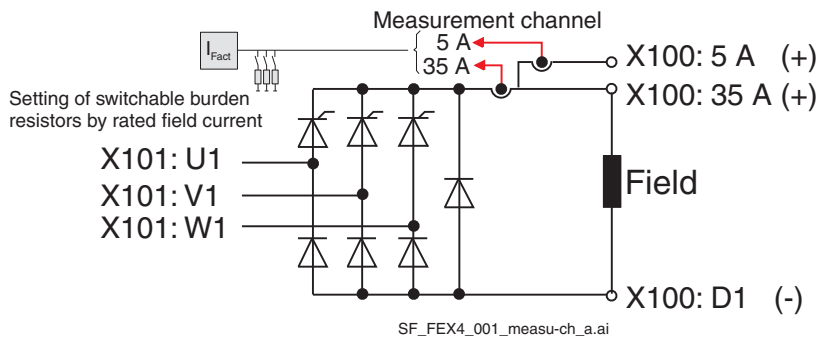

Layout of the SDCS-FEX-4

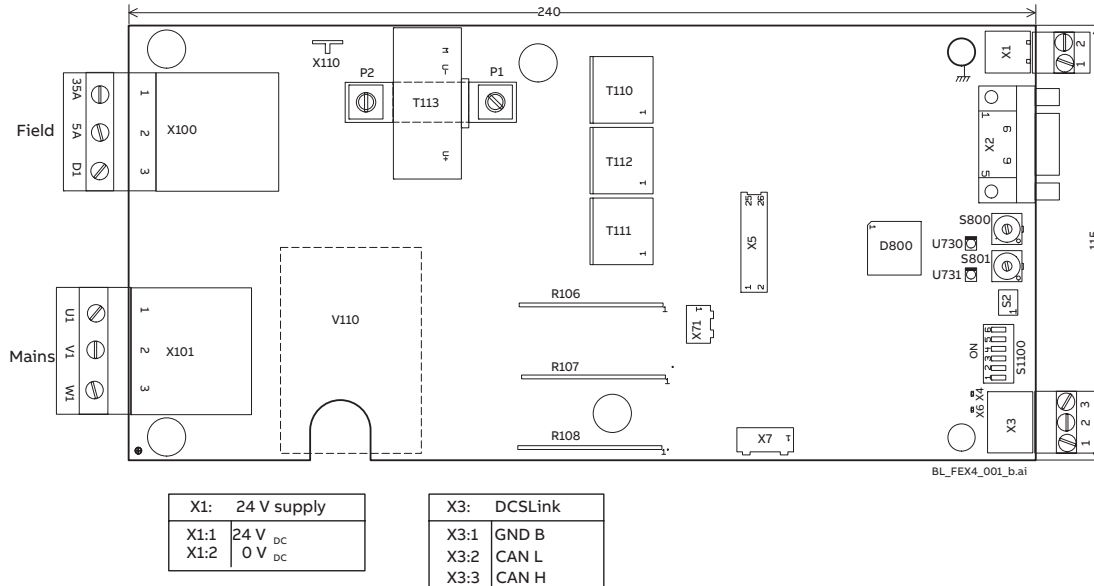

Cross section FEX-425, DCF803-0016, DCF803-0035:

Terminal	Flex cable	
	Max [mm ²]	Torque [Nm]
X1 X3	0.25 ... 1.5	0.5 ... 0.6
X100 Field X101 Mains	6 / AWG10	1.5 ... 1.7

Electrical data

Power part	
AC input voltage	110 V -15% ... 500 V +10%; single or 3-phase
AC input current	< DC output current
Frequency	Same as DCS converter
AC isolation voltage	600 V
Line reactor	External
Line fuses	KTK25 for FEX-425-Int; external for DCF803-0016 and DCF803-0035
DC output current ①	0.3 A ... 16 A = DCF803-0016 0.3 A ... 25 A = FEX-425-Int 0.3 A ... 35 A = DCF803-0035
Powerloss	< 130 W (at rated current)
Auxiliary supply	
DC input voltage	24 V _{DC}
DC input current	< 200 mA supplied via X51 of SDCS-DSL-H1x
Buffering	10 ms

① 3-phase or single-phase operation.

Control unit

The control includes the following main blocks:

- Micro controller H8 for current control, synchronization and fault handling.
- 2 channel measurement of actual field current in the DC circuit.
- High ohmic measurement of AC voltage. Residual resistance to ground ≈ 1.6 MOhm.
- H8 controller for drive-to-drive communication based on CAN standard.
- Driver circuit to fire the half control bridge.
- The firmware is stored in a flash memory and contains:
 - The PI current controller for the field circuit.
 - The fault and reset logic.
 - The synchronization and PLL function.
 - The setting of the current measurement channel.

All parameters are set from the armature converter via drive-to-drive communication. The field current reference, actual field current, current control and status bits are cyclic sent via drive-to-drive communication.

The field exciter is equipped with an autoscaling function of the burden resistors based on the nominal field current of the motor.

Power part

The power part is a 3-phase half controlled bridge with free-wheeling diode.

The external field exciter DCF803-0016 and DCF803-0035 are 3-phase half controlled bridges including snubbers based on the SDCS-FEX-4. Line fuses, line reactors and transformers are installed outside the housing.

The FEX-425-Int (internal field exciter) can only be installed in H5 and H6 modules. The unit is based on a SDCS-FEX-4. For a H5 the supply must be connected via line reactors and fuses located outside of the module.

For a H6 the supply must be connected via line reactors outside of the module. The fuses are installed in the module.

For single-phase operation connect terminals U and W. For single-phase operation an autotransformer for voltage adaptation is recommended.

Please see comparison of output voltage ripple between single-phase and 3-phase operation.

Voltage ripple of voltage U_{DC} depending on operation modes.

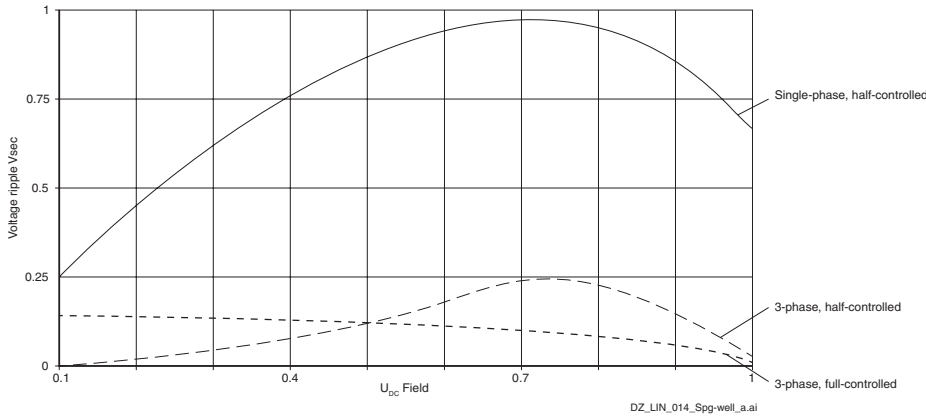

DCSLink communication

The field converter is controlled from armature converter via DCSLink based on CAN hardware.

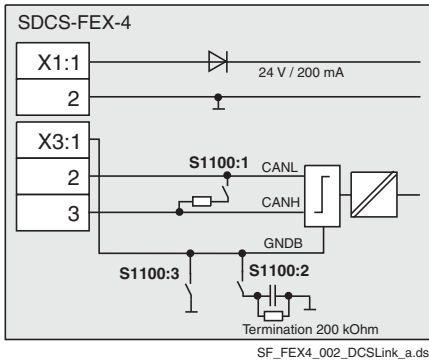

Incoming power		Remarks
24 V	≤ 200 mA	24 V grounded via X51 of SDCS-DSL-H1x

DSL communication		Remarks
Bus termination		
S1100:	1 = ON	120 Ohm
	1 = OFF	No termination
Ground termination		
S1100:	2 = ON	200 kOhm R-C ground termination
	3 = ON	0 Ohm ground termination
	2, 3 = OFF	No termination

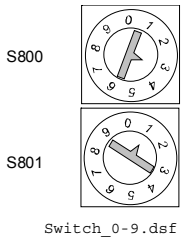

Node address is set by:
 S800 digit 0 (node address 00 is not possible!).
 S801 digit 10.

Same node address must be selected in the corresponding armature converter.
 Example: Node address = 13 ==> S800 = 3 and S801 = 1.

The communication speed is set by S1100.

S1100:6	S1100:5	S1100:4	Baudrate [kBaud]	Selection in armature converter, parameter (94.02)
OFF	OFF	OFF	20	0
OFF	OFF	ON	50	1
OFF	ON	OFF	125	2
OFF	ON	ON	250	3
ON	OFF	OFF	500	4
ON	OFF	ON	800	5
ON	ON	OFF	888	6
ON	ON	ON	1000	7

RS232-Port

The RS232 interface is used for download the 'Field exciter firmware package'.

The firmware download is activated by setting S2:1-2 before the auxiliary voltage is switched ON.
Field exciter mode is S2:3-4 (default).

Diagnostics

All messages are sent to the armature converter and displayed in Signals 04.26, 04.27, 04.36 and 04.37. If the communication is broken or node numbers are mixed up the simple fault display on the SDCS-FEX-4 can be used.

Therefore the unit is equipped with two small LEDs.

V730 = Green

V731 = Yellow

Following messages are displayed:

Both OFF	No 24 V supply
Green and yellow continuous	No firmware or S2:1-2
Green blinking	16 A / 25 A / 35 A output active, waiting for DCSLink communication
Green continuous	16 A / 25 A / 35 A output active, DCSLink communication OK
Yellow blinking	5 A output active (X100:2), waiting for DCSLink communication
Yellow continuous	5 A output active (X100:2), DCSLink communication OK
Green and yellow toggling:	

X times yellow	Y times green	Warning or Fault
X = 1	Y = 1	Warning Phase missing, see parameters 28.63 / 42.68
	Y = 2	Warning Temperature heatsink
	Y = 6	Warning Parameters added
	Y = 7	Warning Parameter up- or download failed
	Y = 8	Warning Compatibility
	Y = 9	Warning Parameters restored
X = 2	Y = 1	Fault DCSLink communication
	Y = 2	Fault Supply voltage synchronization
	Y = 3	Fault Overcurrent
	Y = 4	Fault Fast voltage rise, see parameters 28.62 / 42.67
	Y = 5	Fault AC supply voltage < 30 V _{AC}
	Y = 6	Fault AC supply voltage > 650 V _{AC}
	Y = 9	Fault Temperature heatsink
	Y = 10	Fault Parameter flash read
	Y = 11	Fault Compatibility
	Y = 12	Fault Auxiliary voltage
	Y = 14	Fault General hardware (no reset possible)
	Y = 15	Fault General firmware (no reset possible)

[Line reactors \(L3\).](#)

[Autotransformer \(T3\).](#)

[Fuses \(F3.x\).](#)

DCF803-0016 and DCF803-0035 configuration (H1 ... H8)

3-phase connection, see also parameters 28.63 and 42.68.

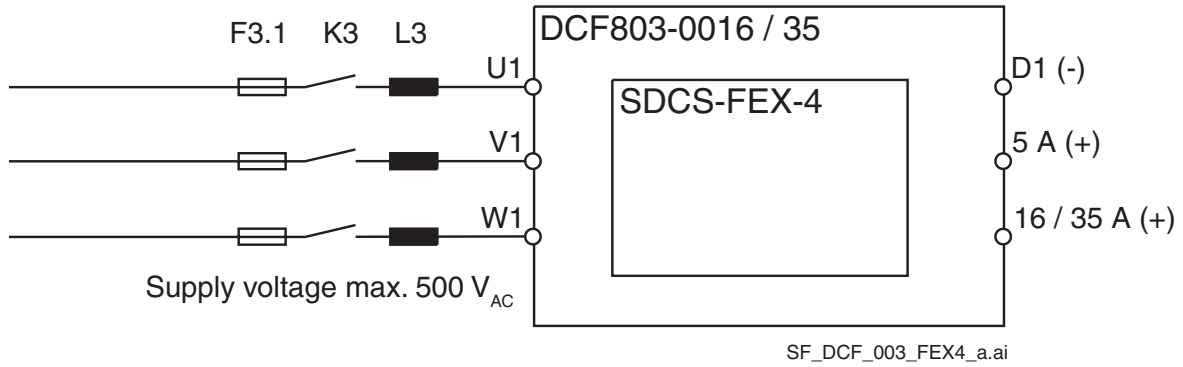

Single-phase connection, see also parameters 28.63 and 42.68.

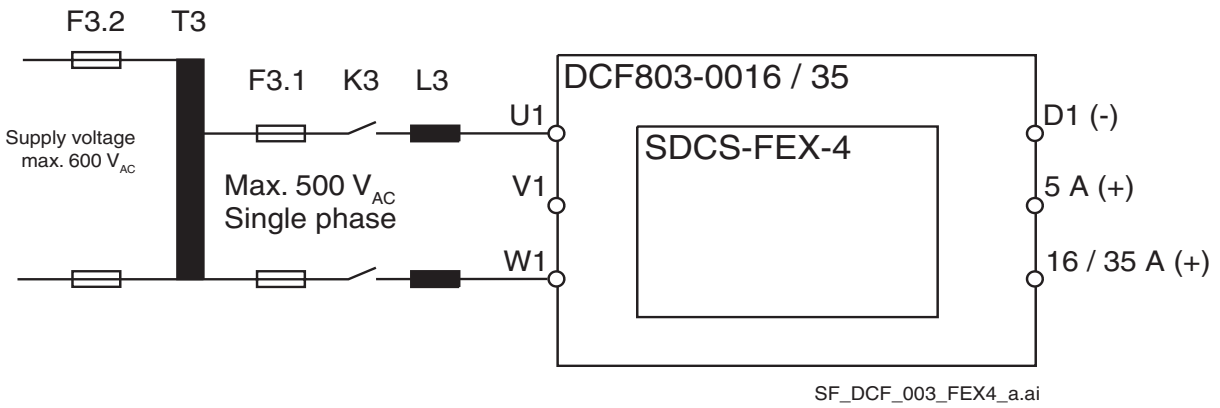

Dimensions

DCF803-0016

Dimensions in mm
Weight appr. 6 kg

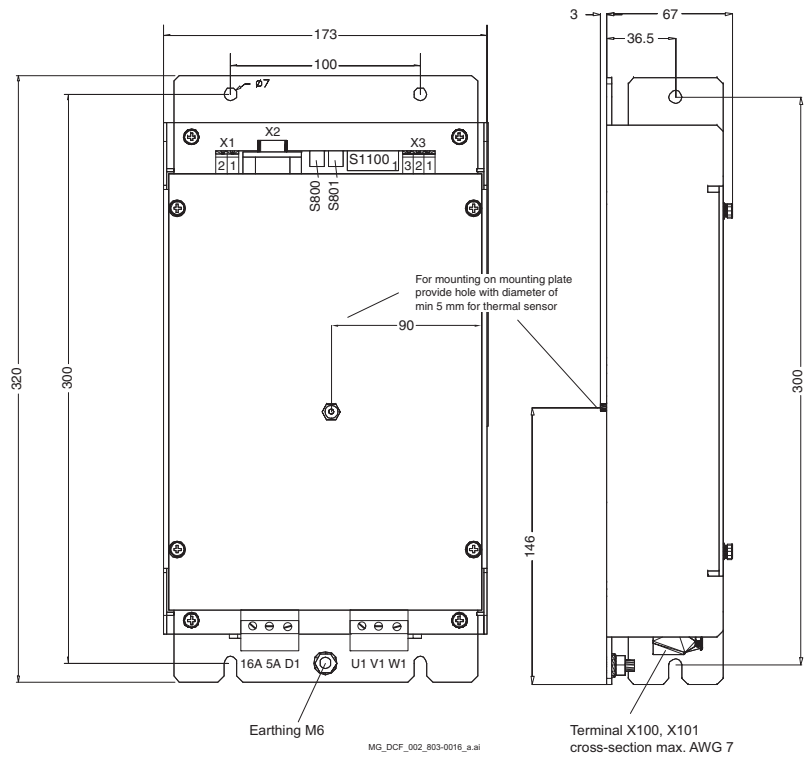

DCF803-0035

Dimensions in mm
Weight appr. 6 kg

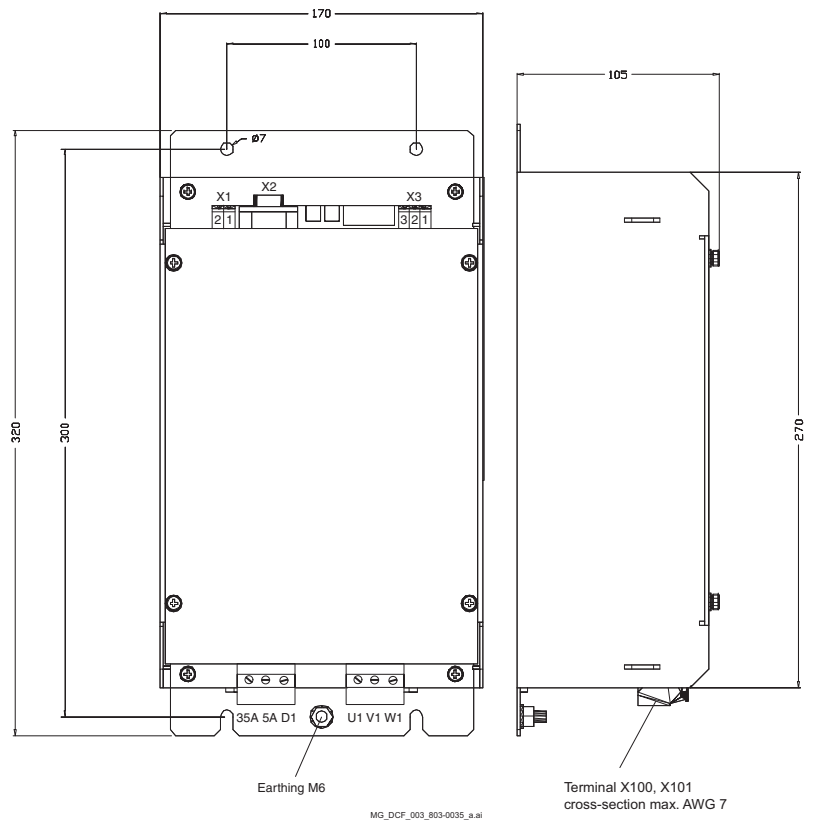

FEX-425-Int configuration (H5)

3-phase connection, see also parameters 28.63 and 42.68.

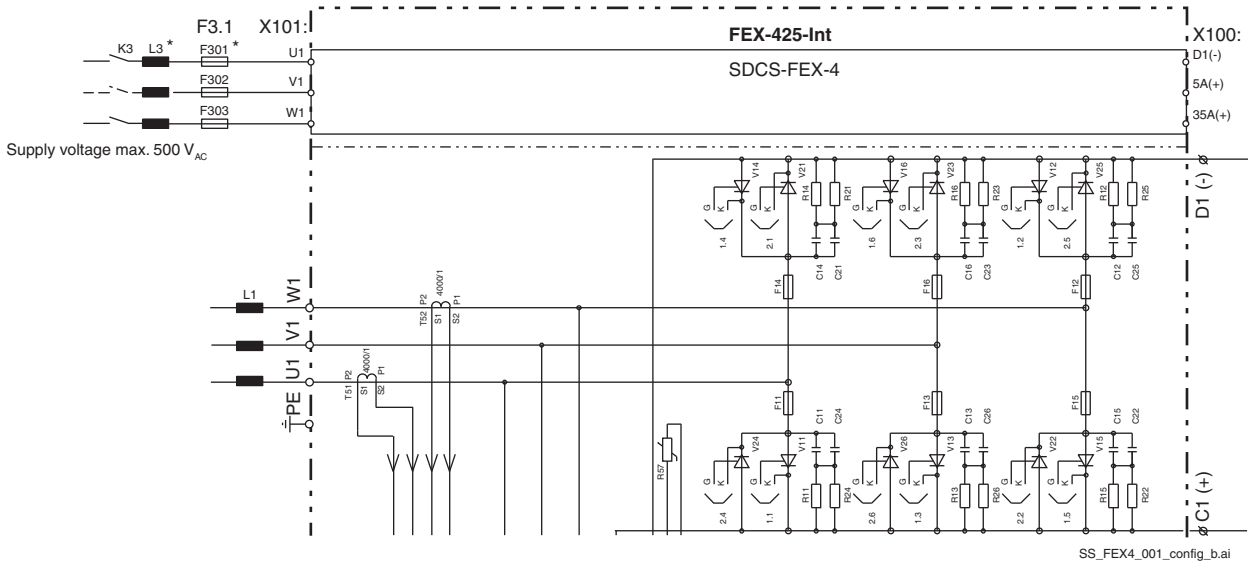

Single-phase connection, see also parameters 28.63 and 42.68.

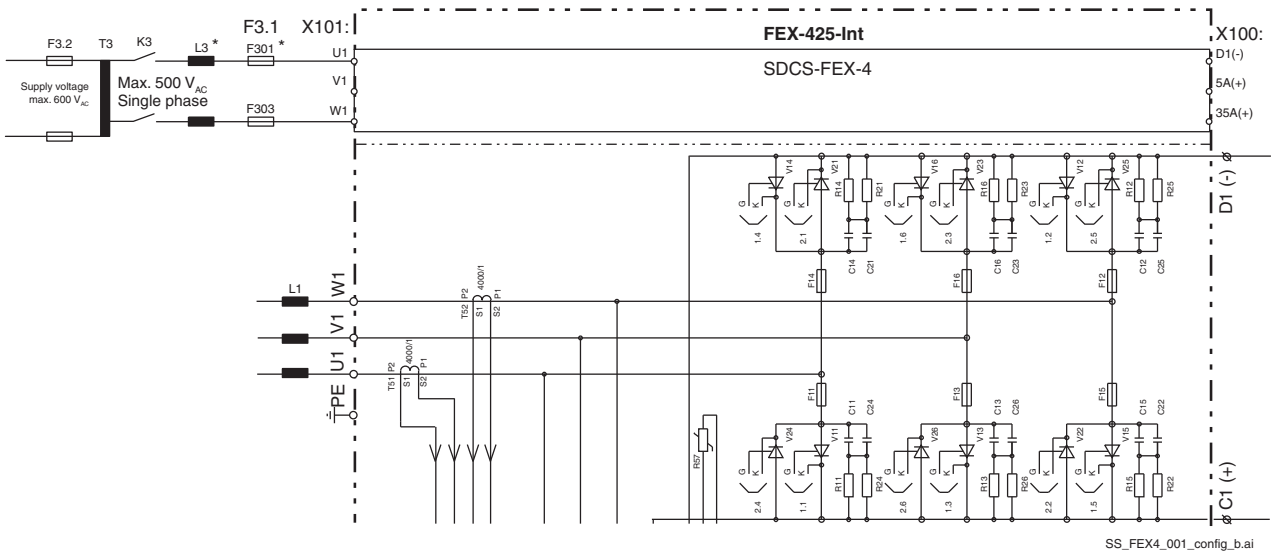

*** Note:** Field line reactor and field fuses are external!

Further information about line reactors see sections [Line reactors \(L3\) \(ND30\)](#) and [Line reactors type ND401... 413 \(ND402\)](#) in this chapter.

FEX-425-Int configuration (H6)

3-phase connection, see also parameters 28.63 and 42.68.

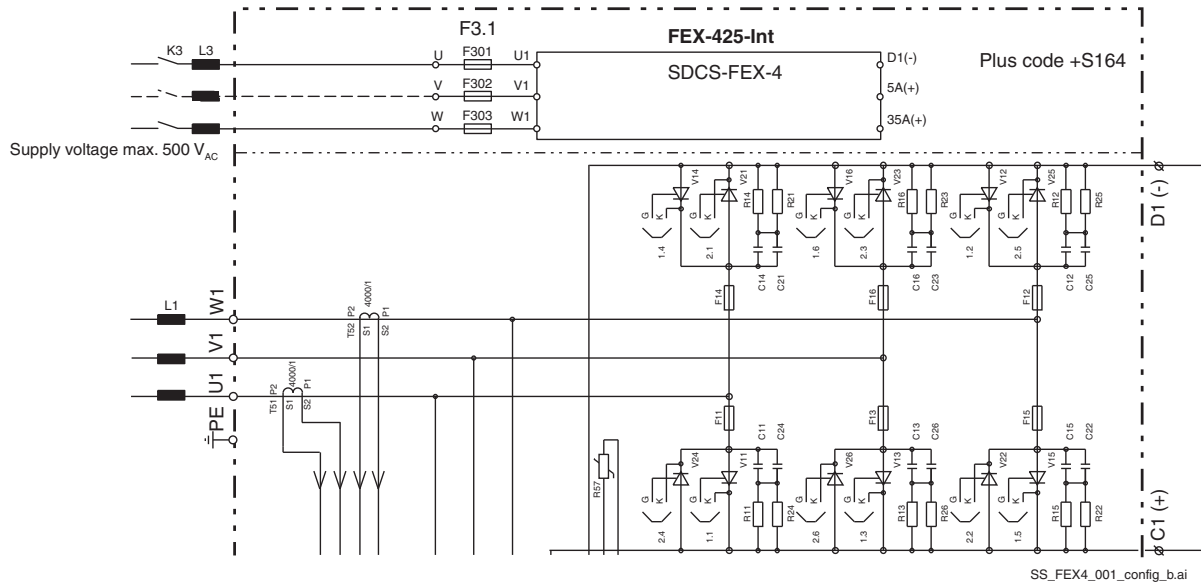

Single-phase connection, see also parameters 28.63 and 42.68.

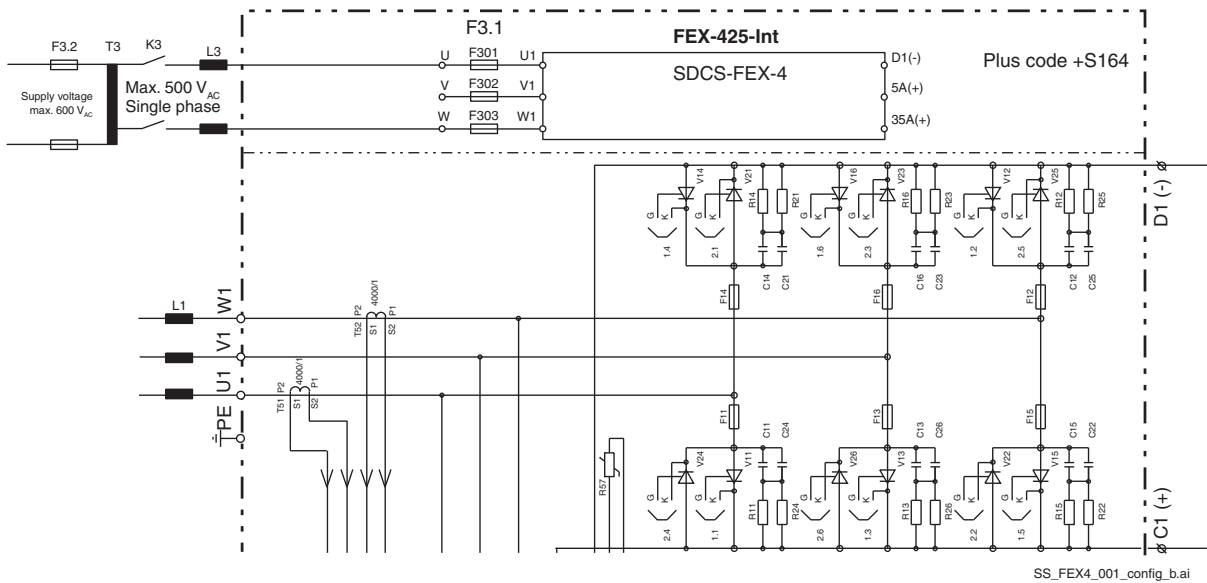

Further information about line reactors see sections [Line reactors \(L3\) \(ND30\)](#) and [Line reactors type ND401 ... 413 \(ND402\)](#) in this chapter.

DCF803-0050, DCF804-0050, DCF803-0060 and DCF804-0060

DCF803-0050 / 0060 and DCF804-0050 / 0060 are external single-phase field converters. The **half controlled** (1-Q) field exciters DCF803-0050 / DCF803-0060 include the SDCS-FEX-82, two thyristor/diode power modules and auxiliaries (power supply, line reactor L1). The **full controlled** (4-Q) field exciters DCF804-0050 / DCF804-0060 include the SDCS-FEX-81, four anti-parallel thyristor power modules and auxiliaries (power supply, line reactor L1). The control structure is similar to the SDCS-FEX-4 in single-phase operation. A micro controller is used for controlling the field current and firing. The DC current is measured using an AC current transformer.

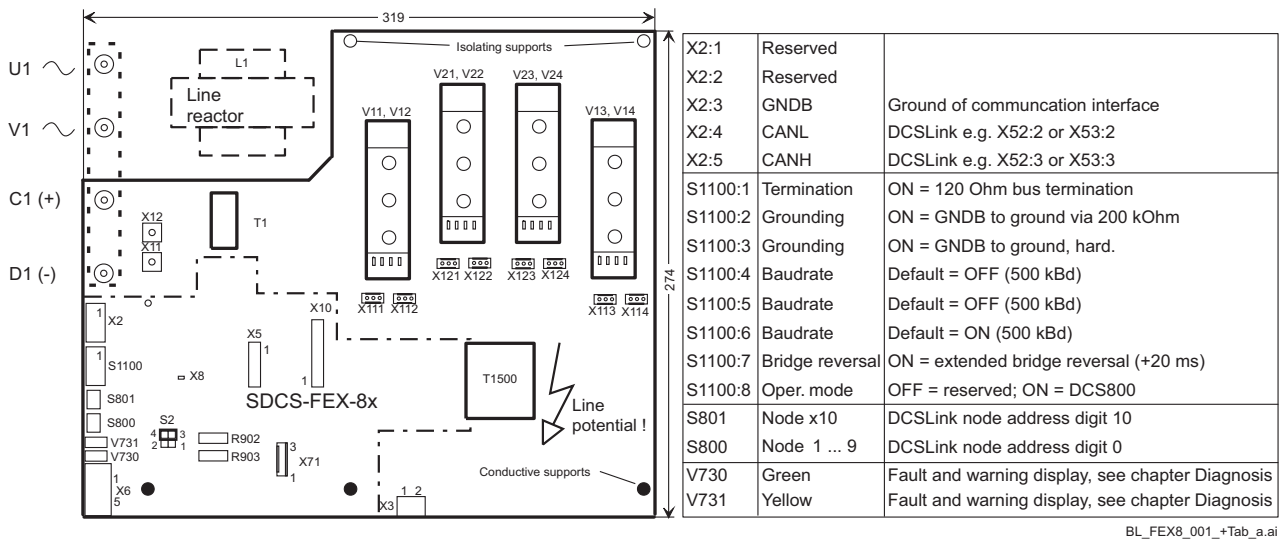
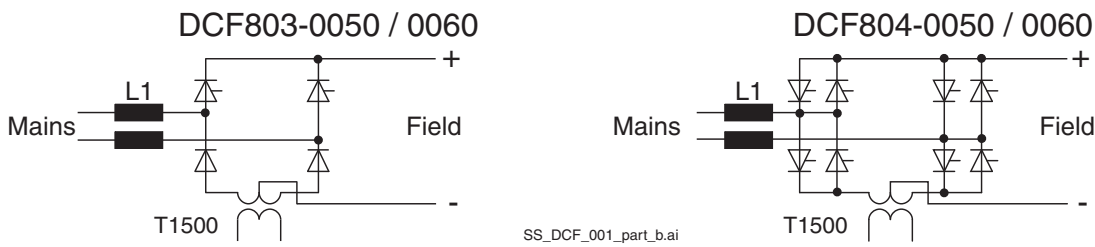

Cross section DCF803-0050, DCF803-0060, DCF804-0050, DCF804-0060:

Terminal	Flex cable		
	Max [mm²]	Torque [Nm]	
X2 X3	0.25 ... 1.5	0.5 ... 0.6	
X:U1 X:V1 X:C1 X:D1	10	10	M6
PE	10	10	M6

Accessories

Electrical data

Power part	
AC input voltage	110 V -15 % ... 500 V +10 %; single-phase
AC input current	< DC output current
Frequency	Same as DCS module
AC isolation voltage	690 V
Line reactor (L1)	160 μ H; 45 ... 65 Hz (built in)
DC output current ① 50 A	0.3 A ... 50 A
DC output current ① 60 A	0.3 A ... 60 A; forced cooling (2 x fan)
Power loss at $I_{F \text{ rated}}$	< 180 W (at rated current)
Load condition	Always L/R > 100 ms (saturation)
X2 Serial communication	
X2: 1	Reserved
X2: 2	Reserved
X2: 3	GNDB, ground of commutation interface
X2: 4	CANL
X2: 5	CANH
X3 Auxiliary voltage	
AC input voltage	110 V -15 % ... 230 V +10 %; single-phase
Frequency	45 ... 65 Hz
AC input power	15 W; 30 VA
Inrush current	< 5 A / 20 ms
Mains buffering	Min. 30 ms
X4 Fan supply	
AC input voltage	230 V_{AC} ; single-phase
Frequency	45 ... 65 Hz
AC input current	0.15 A

① If Field weakening is needed, the minimum field current of the motor at top speed must be higher than 0.3 A.

Electronic power supply

X3 is connected to a switch mode power supply with mains of 230 V_{AC} or 115 V_{AC} .

The power supply unit provides the galvanic isolated DC voltages 30 V, 15 V, 5 V and -15 V for the control electronics.

In addition the power supply generates galvanically isolated 5 V for the serial communication drivers. The voltages can be measured at following terminals:

Voltages	Terminals	Ground
+5 V	X10:18	X10:16 (GND)
+30 V	X10:20	X10:16 (GND)
+15 V	X10:19	X10:16 (GND)
-15 V	X10:17	X10:16 (GND)
+ 5 V	X7:1	X8:1 (GNDB)

Control unit

The control unit includes the following main blocks:

- Micro controller H8 for control and firing.
- Actual DC current measurement using an AC current transformer.
- High ohmic measurement of AC and DC voltage.
Residual resistance to ground = 3.5 MΩ (DCF803
= 1.9 MΩ (DCF804)
- RS485 interface and DCSTLink interface to the converter's control board SDCS-CON-H01.
- The firmware of the field exciter is stored in a flash memory and contains:
 - The PI current controller for the field circuit.
 - The fault and reset logic.
 - The synchronization and PLL function.
 - The bridge reversal function (only DCF804-0050 / 0060).

All control parameters are set from armature converter via drive-to-drive communication. The field current reference, actual field current, current control and status bit are cyclic sent via drive-to-drive communication.

The field exciter is equipped with an autoscaling function of the burden resistors based on the nominal field current of the motor.

Power part

The DCF803-0050 / 0060 is a half-controlled single-phase bridge. A half controlled bridge does not need a free wheeling circuit.

The DCF804-0050 / 0060 is a full-controlled single-phase bridge. During normal operation it is fired in half controlled mode to reduce the current ripple.

Full controlled bridges require separate freewheeling circuits. The firing control enables the freewheeling of a thyristor if the DC voltage increases. See also parameters 28.62 and 42.67 in the armature converter.

A MOV (Metal Oxide Varistor) protects the AC input against voltage spikes from the mains.

Another MOV protects the DC output against voltage surges which can be caused by the field winding of a DC machine.

The power section is equipped with a line reactor (L1). Thus, an external line reactor is not needed. Single-phase field exciters are typically supplied by autotransformers if the rated field voltage is less than 60 % of the AC supply voltage.

The AC input current can be estimated like this:

$$I_{AC} = 1.1 * I_{DC} * U_{DC} \text{ field} / U_{AC} \text{ supply.}$$

R902

	SDCS-FEX-81	DCF804-0050 / 0060
	SDCS-FEX-82	DCF803-0050 / 0060

R903

	50 A
	60 A

DCSLink communication

The field converter is controlled from armature converter via DCSLink based on CAN hardware.

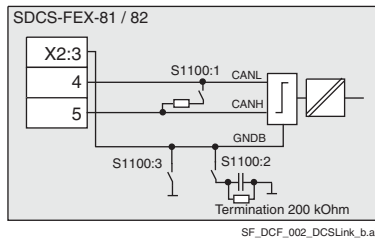

DSL communication		Remarks
Bus termination		
S1100:	1 = ON	120 Ohm
	1 = OFF	no termination
Ground termination		
S1100:	2 = ON	200 kOhm R-C ground termination
	3 = ON	0 Ohm ground termination
	2, 3 = OFF	no termination

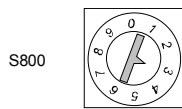

S800

Node address is set by:

S800 digit 0 (node address 00 is not possible!).

S801 digit 10.

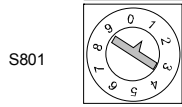

S801

Same node address must be selected in the corresponding armature converter.

Example: Node address = 13 ==> S800 = 3 and S801 = 1.

Switch_0-9.dsf

The communication speed is set by S1100.

S1100:6	S1100:5	S1100:4	Baudrate [kBaud]	Selection in armature converter, parameter (94.02)
OFF	OFF	OFF	20	0
OFF	OFF	ON	50	1
OFF	ON	OFF	125	2
OFF	ON	ON	250	3
ON	OFF	OFF	500	4
ON	OFF	ON	800	5
ON	ON	OFF	888	6
ON	ON	ON	1000	7

RS232-Port

The RS232 interface is used for download the 'Field exciter firmware package'.

The firmware download is activated by setting S2:1-2 before the auxiliary voltage is switched ON.

Field exciter mode is S2:3-4 (default).

Diagnostics

All messages are sent to the armature converter and displayed in Signals 04.26, 04.27, 04.36 and 04.37. If the communication is broken or node numbers are mixed up the simple fault display on the SDCS-FEX-81 / 82 can be used.

Therefore the unit is equipped with two small LEDs.

V730 = Green

V731 = Yellow

Following messages are displayed:

Both OFF	No 24 V supply
Green and yellow continuous	No firmware or S2:1-2
Green blinking	50 A / 60 A output active, waiting for DCSLink communication
Green continuous	50 A / 60 A output active, DCSLink communication OK
Green and yellow toggling:	

X times yellow	Y times green	Warning or Fault
X = 1	Y = 1	Warning Phase missing, see parameter 28.63 and 42.68
	Y = 2	Warning Temperature heatsink
	Y = 6	Warning Parameters added
	Y = 7	Warning Parameter up- or download failed
	Y = 8	Warning Compatibility
	Y = 9	Warning Parameters restored
X = 2	Y = 1	Fault DCSLink communication
	Y = 2	Fault Supply voltage synchronization
	Y = 3	Fault Overcurrent
	Y = 4	Fault Fast voltage rise, see parameter 28.62 and 42.67
	Y = 5	Fault AC supply voltage < 30 V _{AC}
	Y = 6	Fault AC supply voltage > 650 V _{AC}
	Y = 9	Fault Temperature heatsink
	Y = 10	Fault Parameter flash read
	Y = 11	Fault Compatibility
	Y = 12	Fault Auxiliary voltage
	Y = 14	Fault General hardware (no reset possible)
	Y = 15	Fault General firmware (no reset possible)

[Autotransformer \(T3\)](#)

[Fuses \(F3.x\).](#)

DCF803-0050 / 0060 and DCF804-0050 / 0060 configuration (e.g. 2 motors)

The data exchange between SDCS-CON-H01 and DCF803-0050 / 0060 or DCF804-0050 / 0060 via serial communication is configured as a bus. This link is used to transfer references, actual values and settings for up to two field exciters.

The firmware on the SDCS-CON-H01 provides two field exciter functions, one for motor 1 and one for motor 2. The communication works using a screened two-wire cable.

For distances see chapter [DCSLink wiring](#).

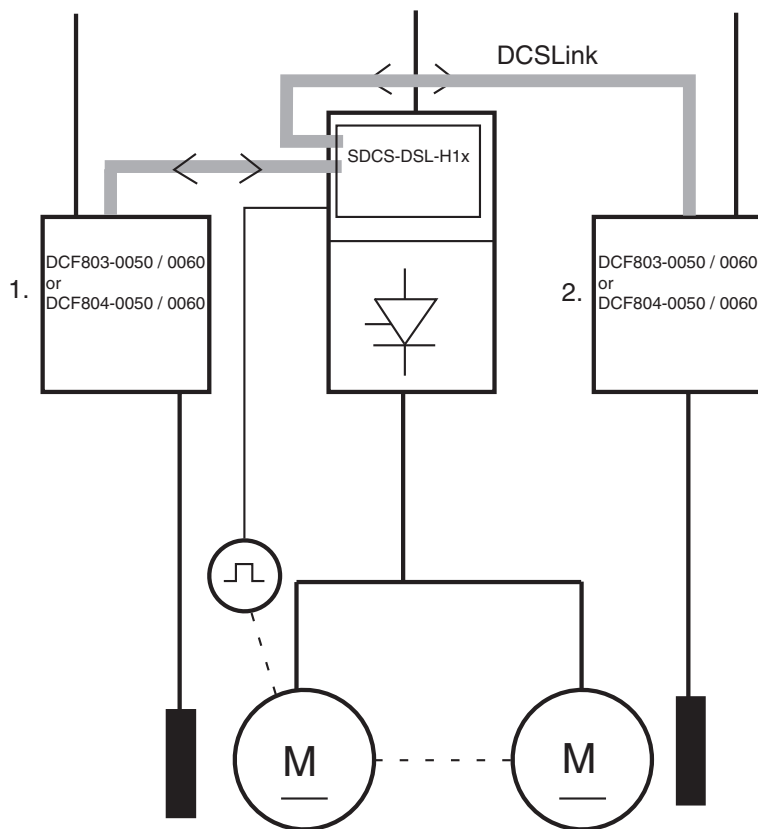

SB_DCF_002_b.ai

Connection example

The DCSLink communication is activated by **S1100:8 = ON**.

The bus setting is made using S1100. The node numbers are set using S800 and S801.

Procedure to change the node number:

- Switch off the electronics supply voltage.
- Set the appropriate switch according to chapter [DCSLink communication](#).
- Switch on the electronics supply voltage.

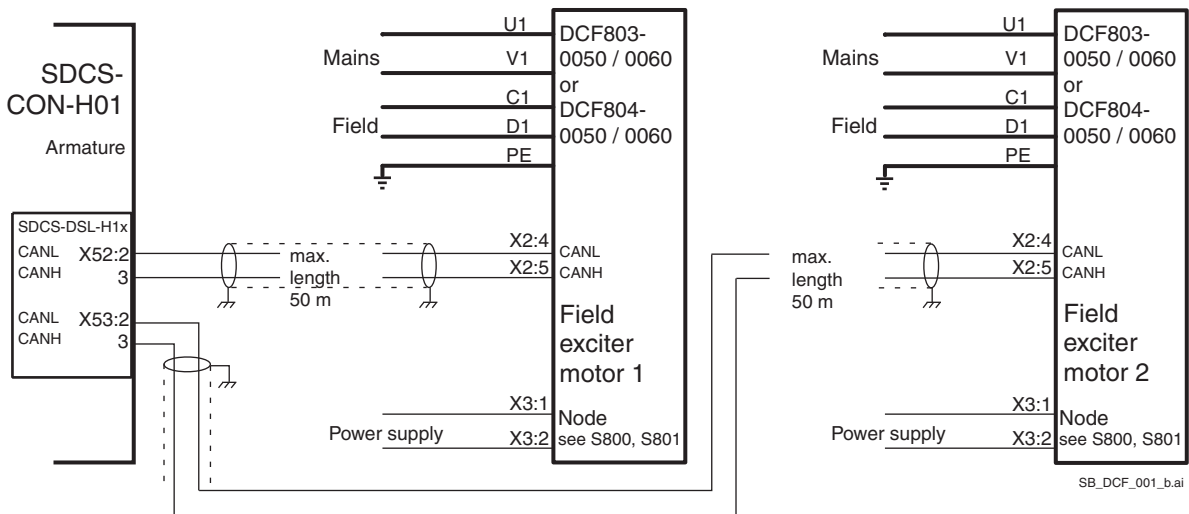

Note:

As standard maximum 2 field exciters can be controlled by one DCS880.

DCF803-0050 / DCF804-0050

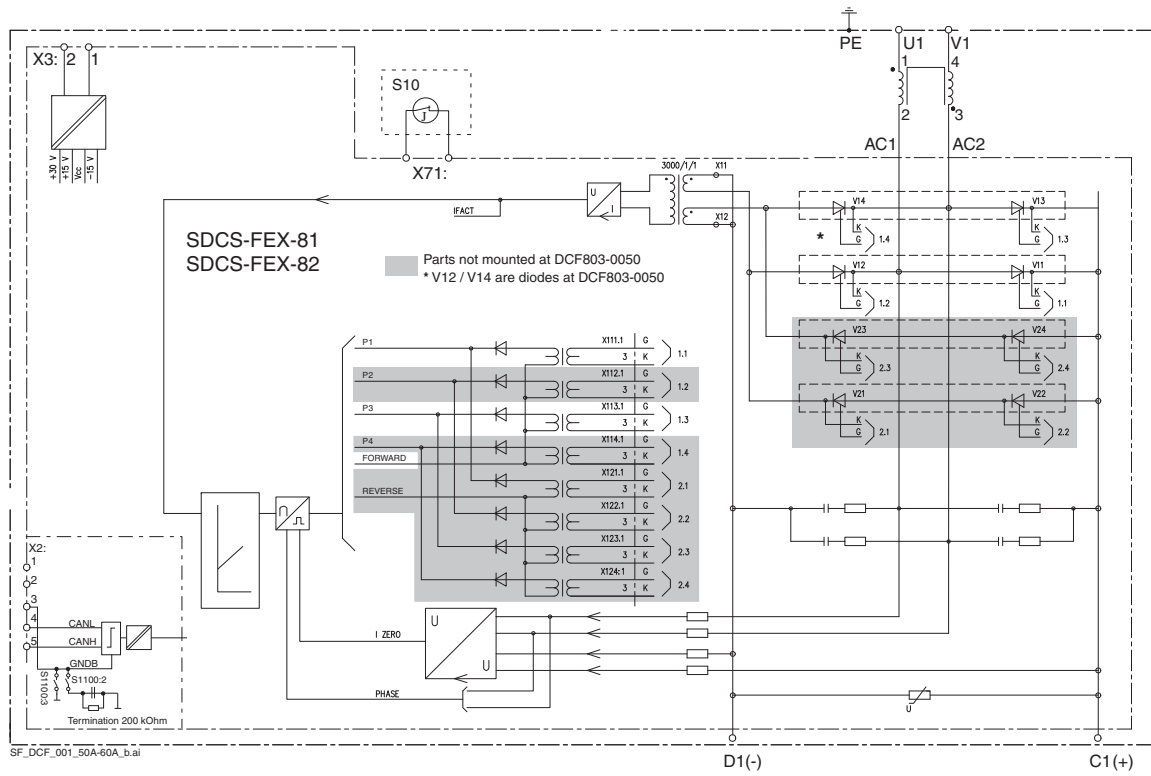

DCF803-0060 / DCF804-0060

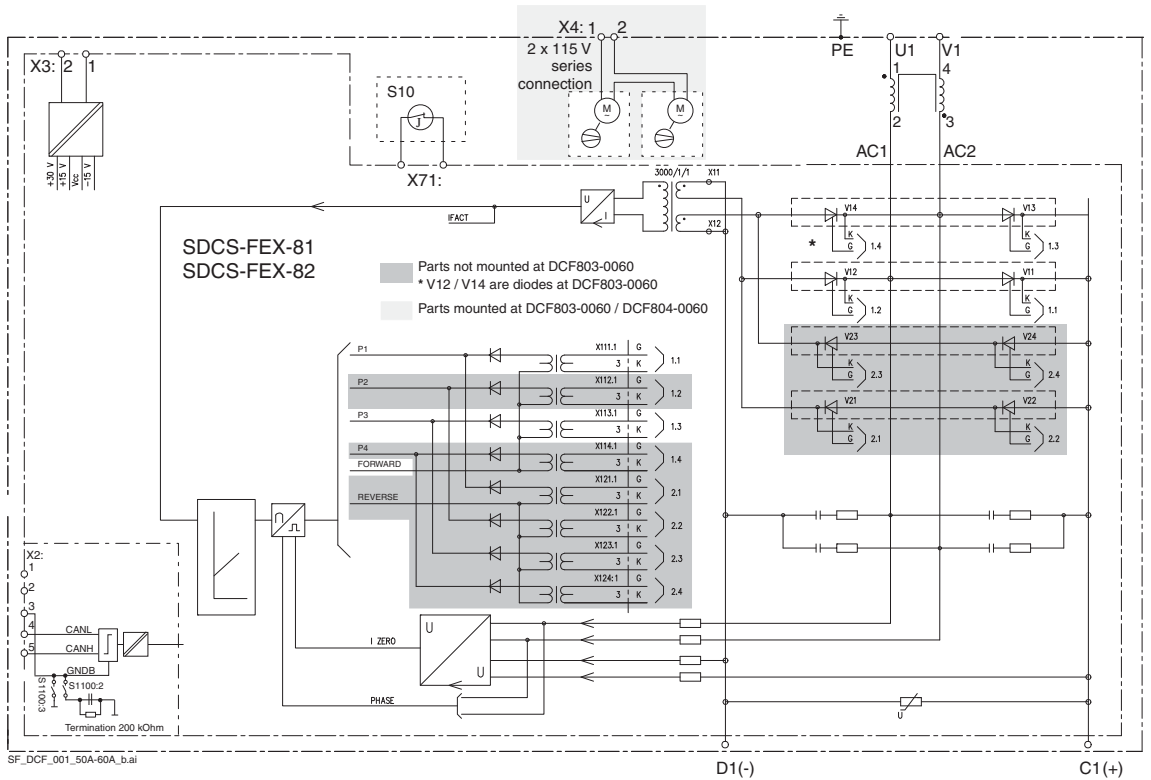

Dimensions

DCF803-0050

DCF804-0050

Dimensions in mm

Weight appr. 11 kg

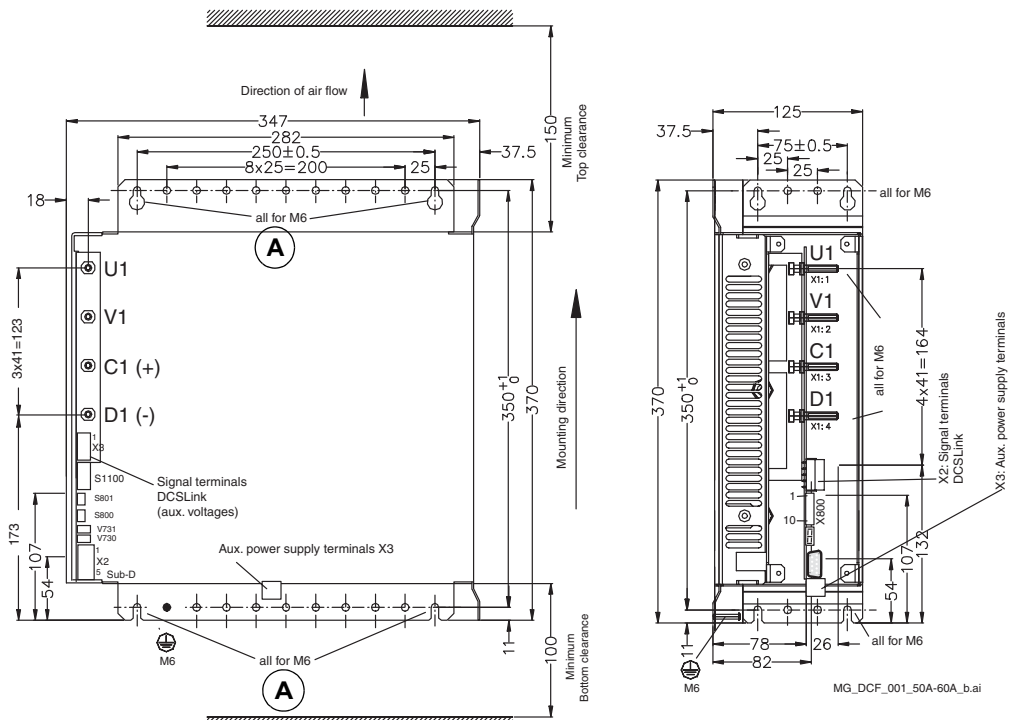

Note: In case of vibrating environments use fixing holes (A).

DCF803-0060

DCF804-0060

Dimensions in mm

Weight appr. 12 kg

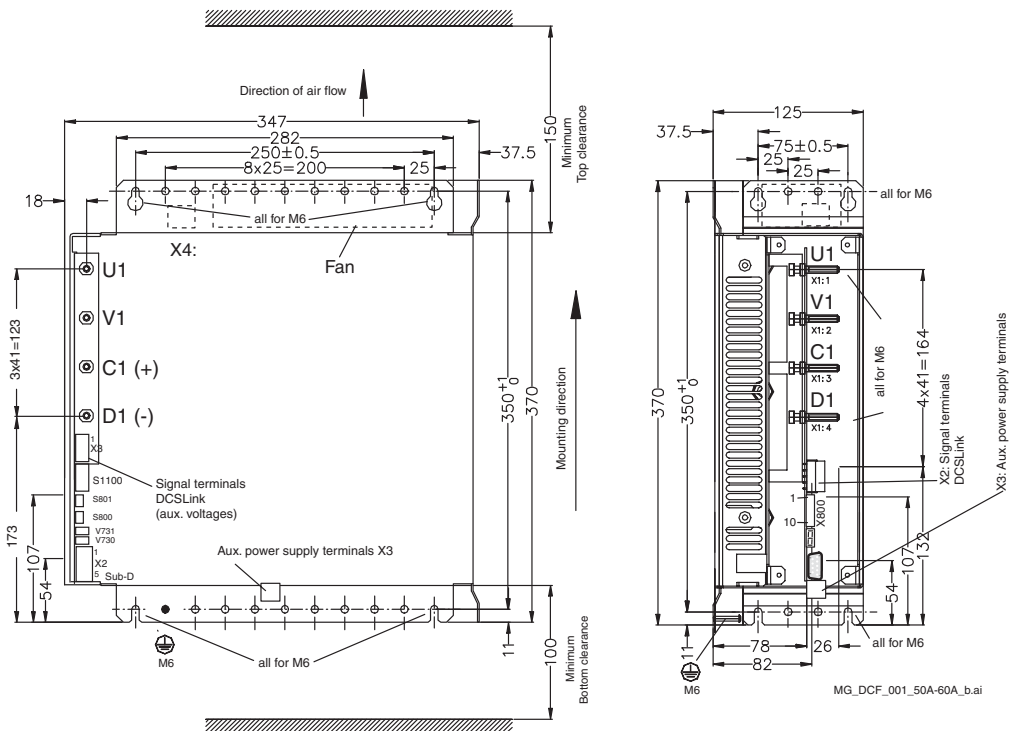

Accessories

DCF505 / DCF506 Overvoltage Protection



Certain converter modules sizes H1 ... H4 can be used as motor field supply. This operation needs separate active overvoltage protection DCF505 or DCF506. They protect the power part against inadmissibly high voltages.

The overvoltage protection activates a free-wheeling circuit between connectors F+ and F- if an overvoltage occurs. The DCF505 / 506 consists of a trigger unit (SDCS-FEP-x) and a free-wheeling thyristor (two anti-parallel thyristors in a DCF506). To connect, use the same size wire as the field exciter.

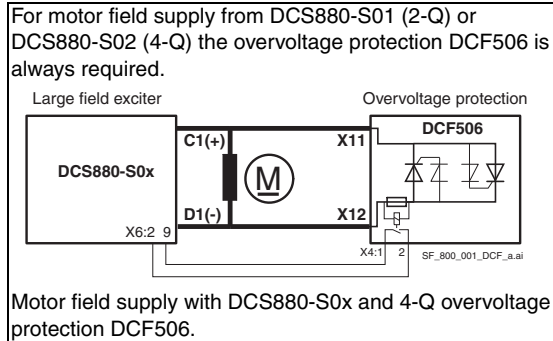
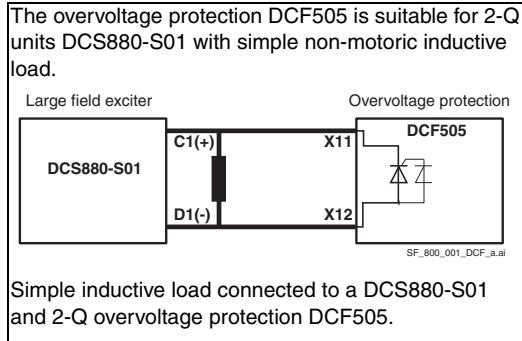
The DCF506 consists of a relay output to indicate a free-wheeling condition to the field converter. When the free-wheeling function is triggered, it will last until the DC current is less than 0.5 A. During this time the relay contacts are closed.



Assignment field supply converter, overvoltage protection and cross-sectional areas

Large field exciters for motor fields ①	Size	Overvoltage Protection	Cross-sectional areas		
			 [mm ²]		 [Nm]
X4		DCF505 DCF506	Flex cable 0.25 ... 1.5		0.5 ... 0.6
2-Q, 400 V / 500 V (IEC) / 525 V (UL)					
DCS880-S01-0020-04/05	H1	DCF506-0140-51	1 x 4	1 x M8	13
DCS880-S01-0045-04/05					
DCS880-S01-0065-04/05					
DCS880-S01-0090-04/05					
DCS880-S01-0135-04/05					
DCS880-S01-0180-04/05	H2	DCF506-0520-51	1 x 10	1 x M8	13
DCS880-S01-0225-04/05					
DCS880-S01-0270-04/05					
DCS880-S01-0315-04/05	H3				
DCS880-S01-0405-04/05					
DCS880-S01-0610-04/05 ②	H4				
4-Q, 400 V / 500 V (IEC) / 525 V (UL)					
DCS880-S02-0025-04/05	H1	DCF506-0140-51	1 x 4	1 x M8	13
DCS880-S02-0050-04/05					
DCS880-S02-0075-04/05					
DCS880-S02-0100-04/05					
DCS880-S02-0150-04/05					
DCS880-S02-0200-04/05	H2	DCF506-0520-51	1 x 10	1 x M8	13
DCS880-S02-0250-04/05					
DCS880-S02-0300-04/05					
DCS880-S02-0350-04/05	H3				
DCS880-S02-0450-04/05					
DCS880-S02-0680-04/05 ②	H4				

① Only these converter types are allowed to be used as large field exciters. A 10 % current de-rating is strongly recommended.

② Limited to 520 A_{DC} field current due to the overvoltage protection.

Inductive load supply for other applications		Overvoltage Protection			
4-Q, 400 V / 500 V (IEC) / 525 V (UL)					
DCS880-S0b-1200-04/05		DCF506-1200-51	1 x 25	1 x M8	13
DCS880-S0b-1500-04/05					
4-Q, 690 V					
DCS880-S0b-0900-07		DCF506-1500-71	1 x 25	1 x M8	13
DCS880-S0b-1500-07					

b = Bridge type

Diagram

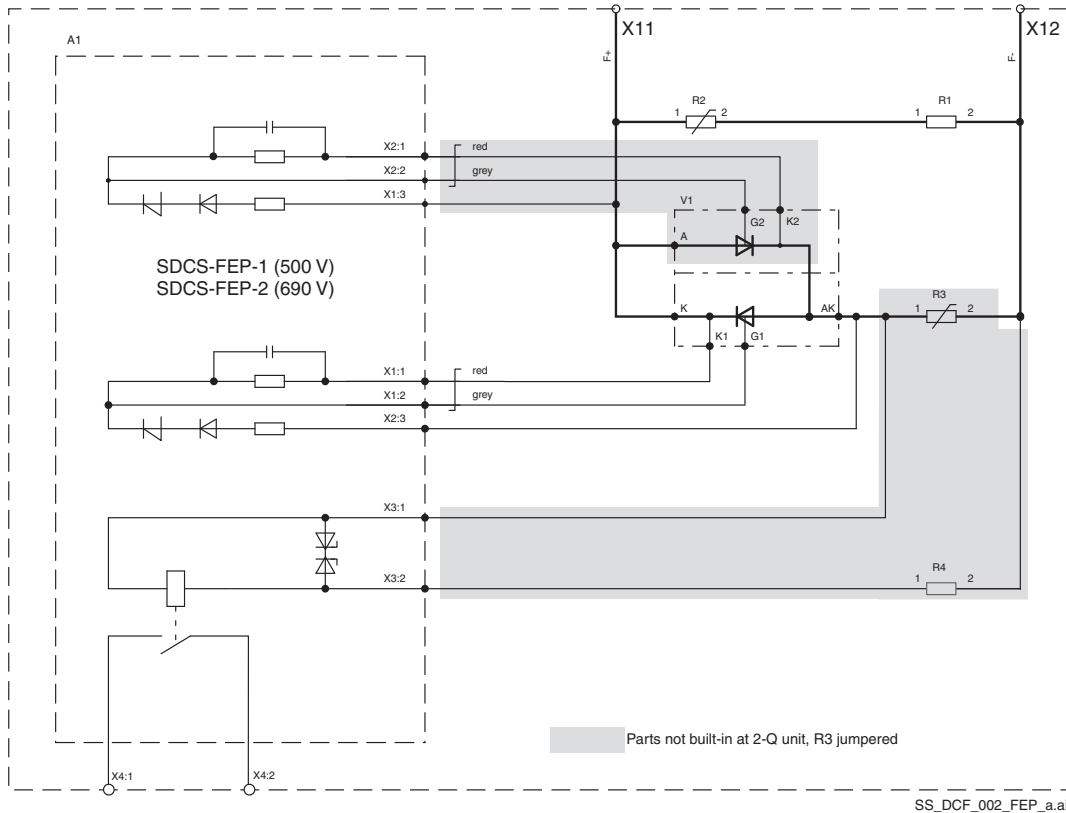

Overvoltage Protection DCF505 / DCF506.

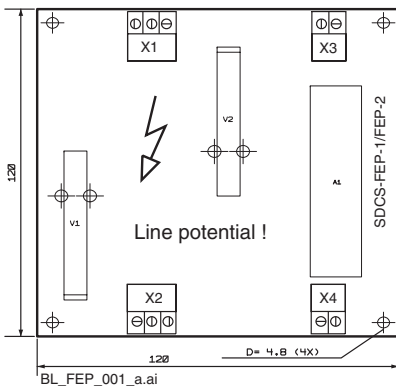

Layout of SDCS-FEP-1 / FEP-2.

Output X4:1, 2

Potential isolated by relay (NO contact)
 Contacts no protected
 Contact rating: **AC**: ≤ 60 V~ / ≤ 50 mA~
DC: ≤ 60V- / ≤ 50 mA-

There are two trigger units in use:

- SDCS-FEP-1 for systems, used for mains up to 500 V (IEC) / 525 V (UL). This board is equipped with a 1,400 V trigger diode.
- SDCS-FEP-2 for systems, used for mains up to 690 V. This board is equipped with a 1,800 V trigger diode.

Accessories

Dimensions

Overvoltage protection

DCF506-0140-51
DCF506-0520-51

Dimensions in mm

Weight appr. 8 kg

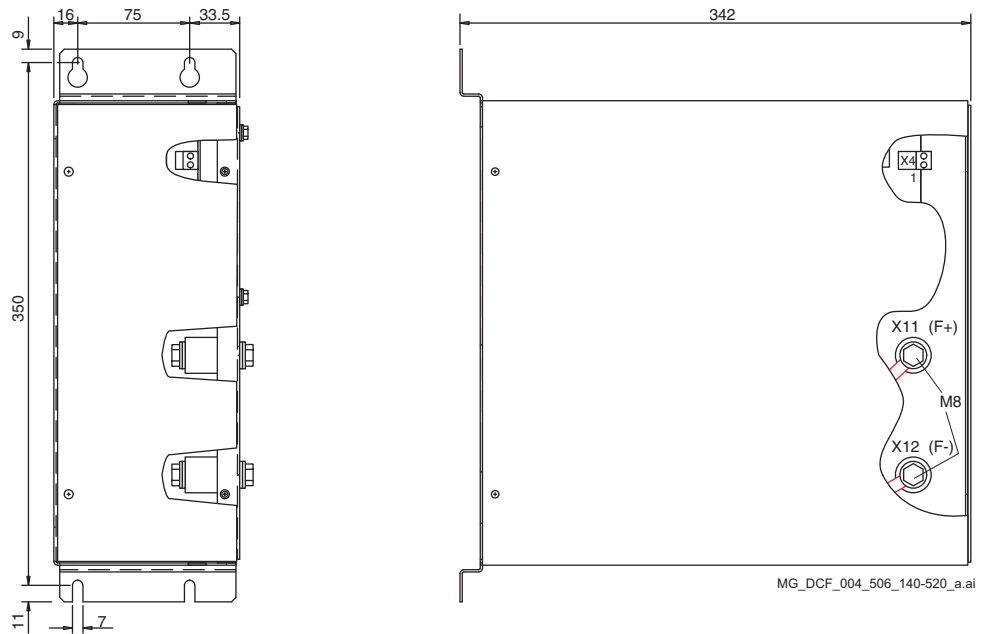

Overvoltage protection

DCF506-1200-51
DCF506-1500-71

Dimensions in mm

Weight appr. 20 kg

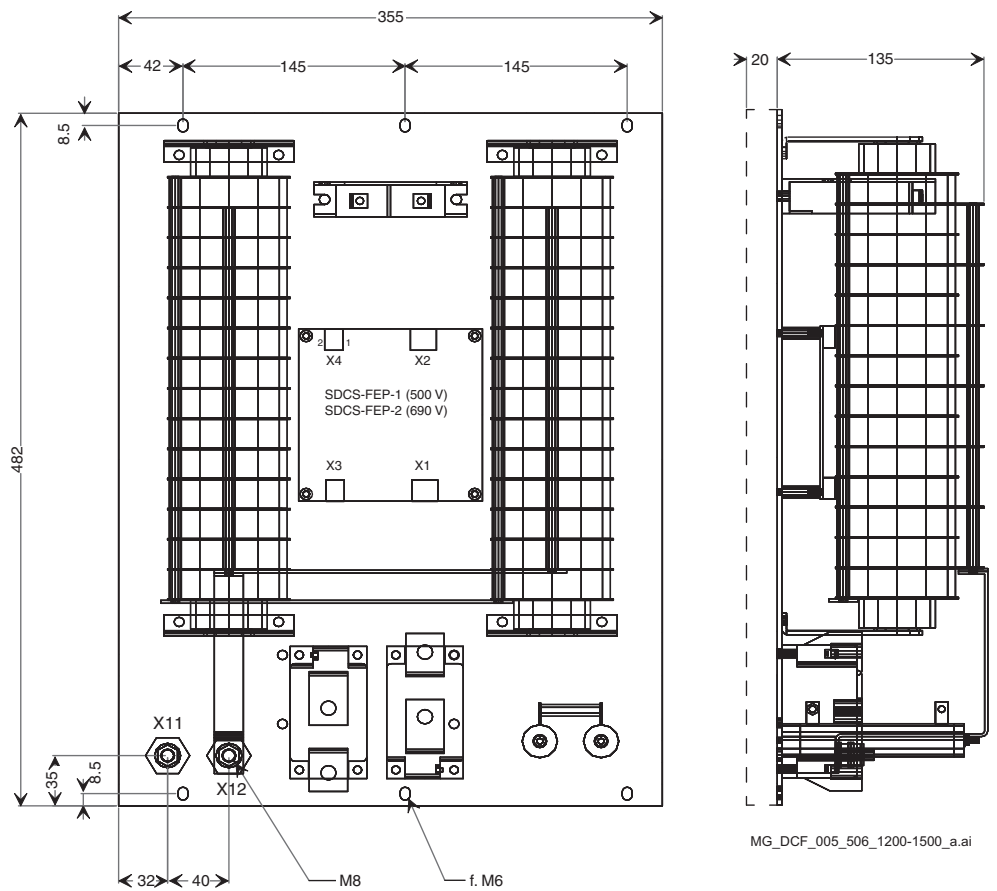

Fuses and fuse holders IEC

Semiconductor fuses and fuse holders for AC and DC power lines

The DCS880 size H1 ... H4 requires external mains fuses. For regenerative drives, DC fuses are recommended. The 4th column of the table below assigns the AC fuse to the unit. In case the unit should be equipped with DC fuses, use the same type of fuse as used on the AC side.

Size	Converter type (2-Q)	Converter type (4-Q)	Fuse type	Fuse size	Resistance [mW]	Fuse holder
-	-	-	10A 660V UR	0	30	OFAX 00 S3L
-	-	-	25A 660V UR		15	OFAX 00 S3L
H1	DCS880-S01-0020-04/05	DCS880-S02-0025-04/05	50A 660V UR	0	6	OFAX 00 S3L
	DCS880-S01-0045-04/05	DCS880-S02-0050-04/05	80A 660V UR		3	OFAX 00 S3L
	DCS880-S01-0065-04/05	DCS880-S02-0075-04/05	125A 660V UR		1.8	OFAX 00 S3L
	DCS880-S01-0090-04/05	DCS880-S02-0100-04/05				OFAX 00 S3L
H2	DCS880-S01-0135-04/05	DCS880-S02-0150-04/05	200A 660V UR	1	0.87	OFAX 1 S3
	DCS880-S01-0180-04/05	DCS880-S02-0200-04/05	250A 600V UR		0.59	OFAX 1 S3
	DCS880-S01-0225-04/05	DCS880-S02-0250-04/05	315A 660V UR	2	0.47	OFAX 2 S3
	DCS880-S01-0270-04/05	DCS880-S02-0300-04/05	500A 660V UR		0.30	OFAX 3 S3
H3	DCS880-S01-0290-06	DCS880-S02-0320-06	700A 660V UR	3		OFAX 3 S3
	DCS880-S01-0315-04/05	DCS880-S02-0350-04/05				OFAX 3 S3
	DCS880-S01-0405-04/05	DCS880-S02-0450-04/05				OFAX 3 S3
	DCS880-S01-0470-04/05	DCS880-S02-0520-04/05				OFAX 3 S3
H4	DCS880-S01-0590-06	DCS880-S02-0650-06	900A 660V UR	4	0.15	3 x 170H 3006
	DCS880-S01-0610-04/05	DCS880-S02-0680-04/05				3 x 170H 3006
	DCS880-S01-0740-04/05	DCS880-S02-0820-04/05				3 x 170H 3006
	DCS880-S01-0900-04/05	DCS880-S02-1000-04/05				1250A 660V UR

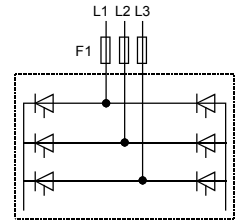

Dimensions of fuses

Size 0 ... 3

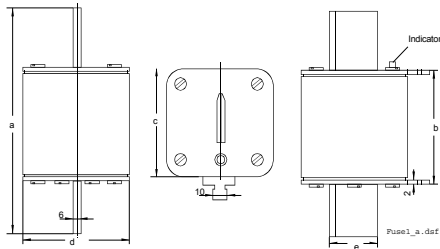

Size	a [mm]	b [mm]	c [mm]	d [mm]	e [mm]
0	78.5	50	35	21	15
1	135	69	45	45	20
2	150	69	55	55	26
3	150	68	76	76	33

Size 4

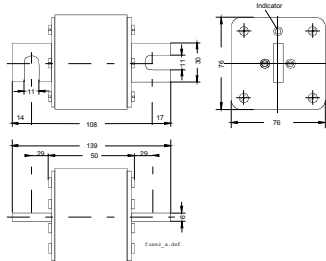

Dimensions of fuse holders

OFAX xx xxx170H 3006 (IP00)

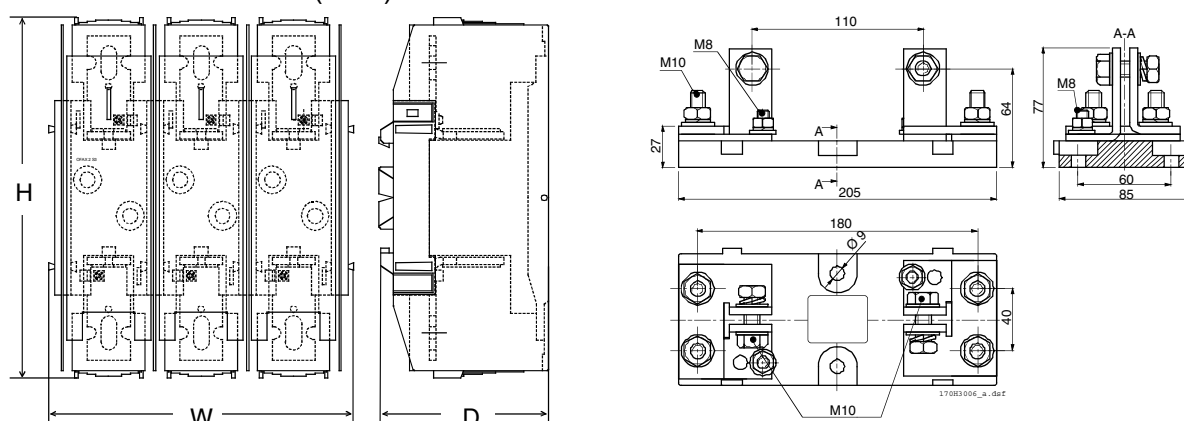

Fuse holder	H x W x D [mm]	Protection
OFAX 00 S3L	148 x 112 x 111	IP20
OFAX 1 S3	250 x 174 x 123	IP20
OFAX 2 S3	250 x 214 x 133	IP20
OFAX 3 S3	265 x 246 x 160	IP20

Line reactors IEC

Line reactors type ND01 ... ND17 ($u_k = 1\%$)

Line reactors of Types ND01 ... ND17 are sized to the unit's nominal current and frequency (50 / 60 Hz). These line reactors with a u_k of 1 % are designed for use in industrial environment (minimum requirements). They have low inductive voltage drop, but deep commutation notches.

Line reactors ND01 ... ND06 are equipped with cables. The larger ones ND07 ... ND17 are equipped with busbars. When connecting them to other components, please consider relevant standards in case the busbar materials are different.

Attention:

Don't use reactor terminals as cable or busbar support!

Line reactor ($u_k = 1\%$)	L [μH]	IRMS [A]	Ipeak [A]	Rated voltage [UN]	Weight [kg]	Power losses		Recommended for armature converter
						Fe [W]	Cu [W]	
ND01	512	18	27	500	2.0	5	16	DCS...-0025
ND02	250	37	68	500	3.0	7	22	DCS...-0050
ND03 ①	300	37	68	600	3.8	9	20	(DCS...-0050)
ND04	168	55	82	500	5.8	10	33	DCS...-0075
ND05 ①	135	82	122	600	6.4	5	30	(DCS...-0100)
ND06	90	102	153	500	7.6	7	41	DCS...-0140
ND07	50	184	275	500	12.6	45	90	DCS...-0260
ND08	56.3	196	294	600	12.8	45	130	DCS...-0320
ND09	37.5	245	367	500	16.0	50	140	DCS...-0350
ND10	25.0	367	551	500	22.2	80	185	DCS...-0520
ND11 ①	33.8	326	490	600	22.6	80	185	(DCS...-0450)
ND12	18.8	490	734	500	36.0	95	290	DCS...-0680
ND13	18.2	698	1047	690	46.8	170	160	DCS...-0900
ND14	9.9	930	1395	500	46.6	100	300	DCS...-1190 / 1200
ND15	10.9	1163	1744	690	84.0	190	680	DCS...-1500
ND16	6.1	1510	2264	500	81.2	210	650	DCS...-2000
ND17	4.0	1800	2700	800	86.0	250	700	DCS...-2500

① not used for DCS880

Line reactors type ND01 ... ND06

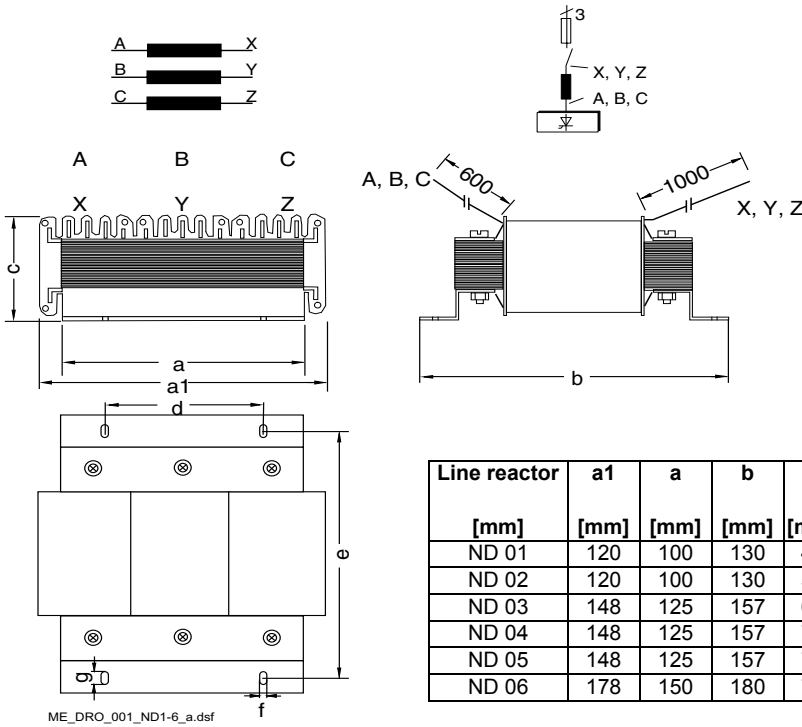

Line reactors type ND07 ... ND12

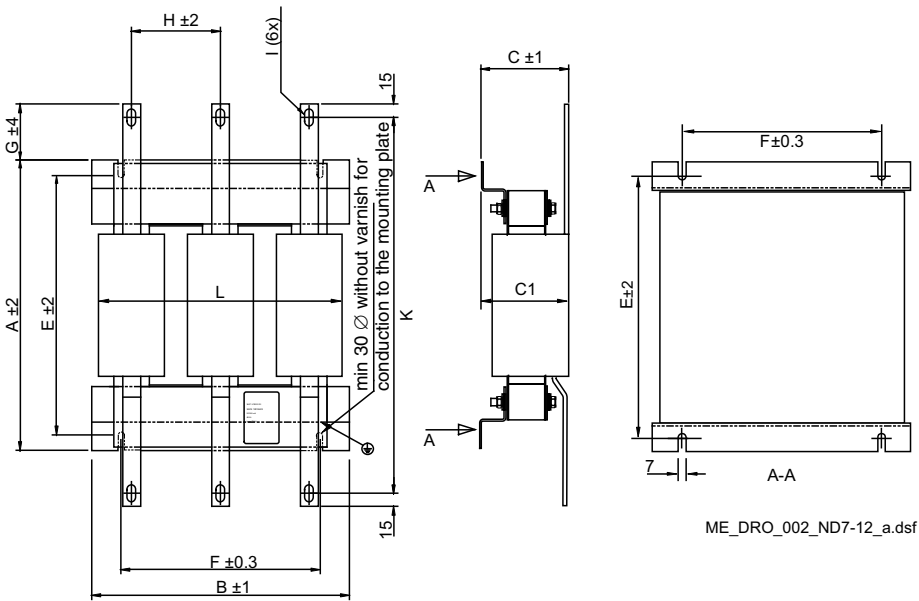

Accessories

Line reactors type ND13, 14 all busbars are 40 x 10

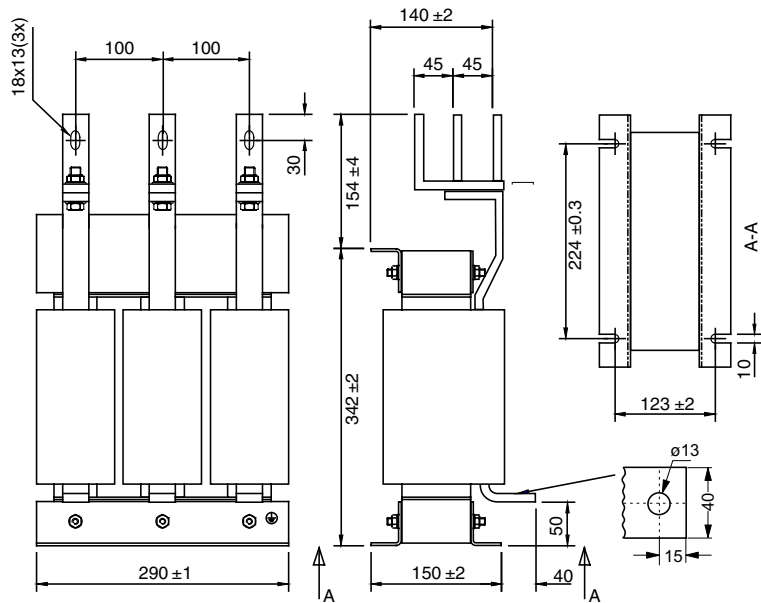

ME_DRO_003_ND13-14_a.dsf

Tightening torque

ND		Torque [Nm]
ND13, ND14	M10	25
ND15, ND16, ND17	M12	50

Line reactors type ND15, 16 all busbars are 60 x 10

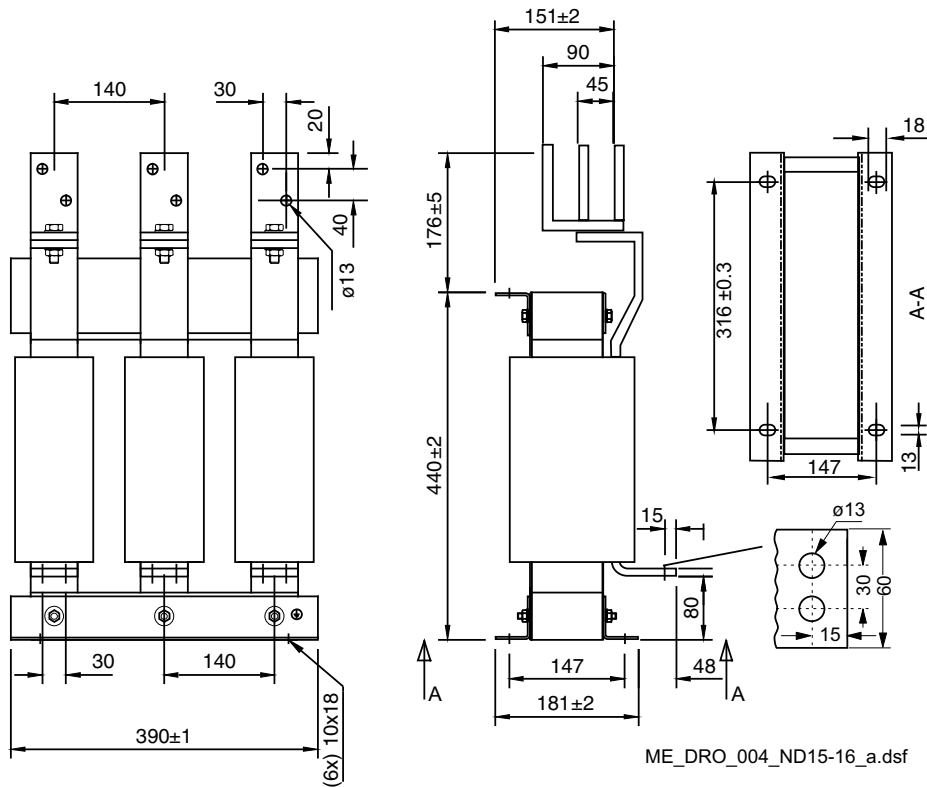

ME_DRO_004_ND15-16_a.dsf

Line reactors type ND17

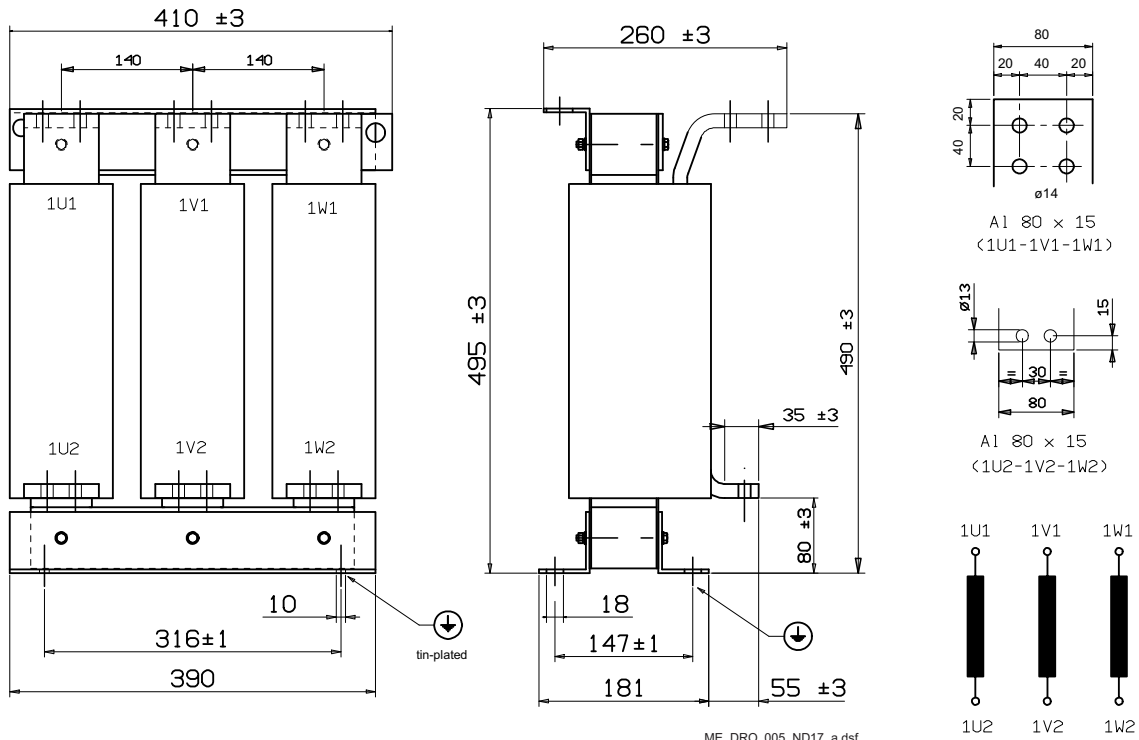

Tightening torque

ND		Torque [Nm]
ND13, ND14	M10	25
ND15, ND16, ND17	M12	50

Line reactors type ND401 ... ND413 ($u_k = 4\%$)

Line reactors of types ND401 ... ND413 are sized to the unit's nominal current and frequency (50 / 60 Hz). These line reactors with a u_k of 4 % are designed for use in light industrial / residential environment. They have high inductive voltage drop, but reduced commutation notches. These line reactors are designed for drives, which usually operate in speed control mode with 400 or 500 V_{AC} mains. Thus, the load cycle has to be taken into account. The percentage which is taken into account for that duty cycle is different depending on the mains.

- For $U_{Mains} = 400\text{ V}_{AC}$ follows $I_{DC1} = 90\%$ of nominal current.
- For $U_{Mains} = 500\text{ V}_{AC}$ follows $I_{DC2} = 72\%$ of nominal current.

Line reactors ND401 ... ND402 are equipped with terminals. The larger ones ND403 ... ND413 are equipped with busbars. When connecting them to other components, please consider relevant standards in case the busbar materials are different.

Attention:

Do not use the line reactor terminals as cable or busbar support!

Line reactor ($u_k = 4\%$)	L [μ H]	IRMS [A]	Ipeak [A]	Rated voltage [V]	Weight [kg]	Power losses		DC current for $U_{mains} = 400\text{ V}_{AC}$	DC current for $U_{mains} = 500\text{ V}_{AC}$
						Fe [W]	Cu [W]		
ND401	1000	18.5	27	400	3.5	13	35	22.6	18
ND402	600	37	68		7.5	13	50	45	36
ND403	450	55	82		11	42	90	67	54
ND404	350	74	111		13	78	105	90	72
ND405	250	104	156		19	91	105	127	101
ND406	160	148	220		22	104	130	179	143
ND407	120	192	288		23	117	130	234	187
ND408	90	252	387		29	137	160	315	252
ND409	70	332	498		33	170	215	405	324
ND410	60	406	609		51	260	225	495	396
ND411	50	502	753		56	260	300	612	490
ND412	40	605	805		62	280	335	738	590
ND413	35	740	1105		75	312	410	900	720

Line reactors type ND401, 402

Line reactor ($u_k = 4\%$)	A [mm]	B [mm]	C [mm]	D [mm]	E [mm]	F [mm]	$\varnothing G$ [mm]	$\varnothing H$ [mm]
ND401	160	190	75	80	51	175	7	9
ND402	200	220	105	115	75	200	7	9

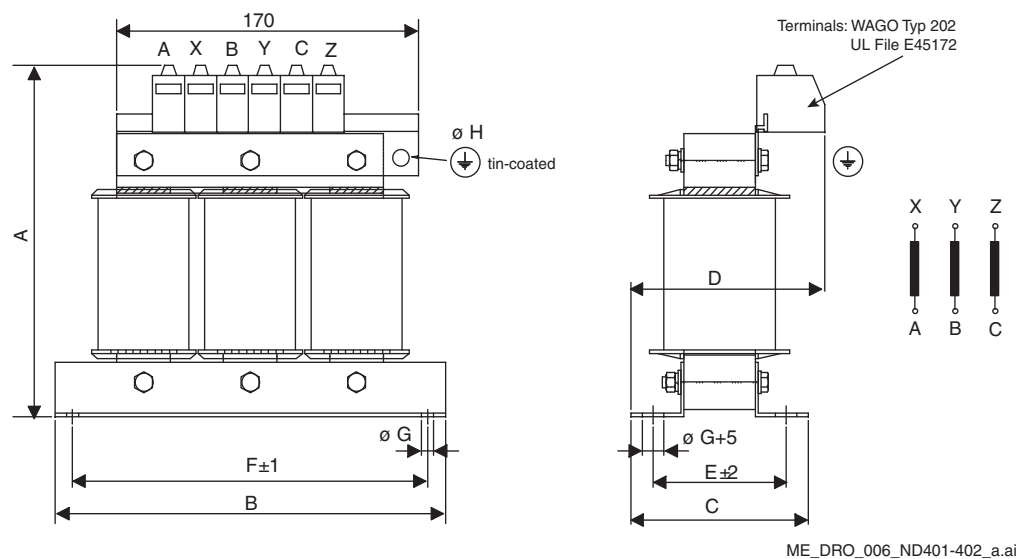

ME_DRO_006_ND401-402_a.ai

Line reactors type ND403 ... ND408

Line reactor (uk = 4 %)	A [mm]	B [mm]	C [mm]	D [mm]	E [mm]	F [mm]	Ø G [mm]	Ø H [mm]	Ø K [mm]		Torque [Nm]
ND403	220	230	120	135	100	77.5	7	9	6.6	M6	6
ND404	220	225	120	140	100	77.5	7	9	6.6		
ND405	235	250	155	170	125	85	10	9	6.6		
ND406	255	275	155	175	125	95	10	9	9	M8	18
ND407	255	275	155	175	125	95	10	9	11	M10	37
ND408	285	285	180	210	150	95	10	9	11		

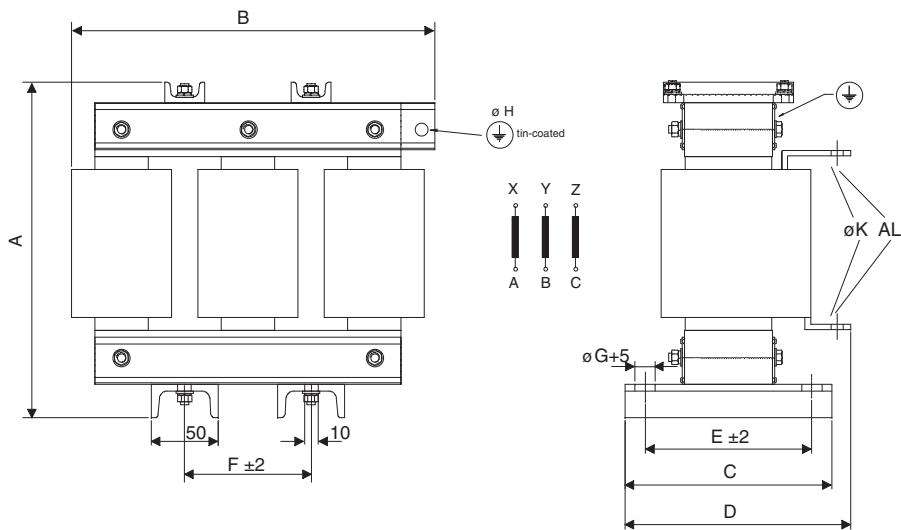

ME_DRO_007_ND403-408_a.ai

Line reactors type ND409 ... ND413

Line reactor (uk = 4 %)	A [mm]	B [mm]	C [mm]	D [mm]	E [mm]	F [mm]	Ø G [mm]	Ø H [mm]	Ø K [mm]		Torque [Nm]
ND409	320	280	180	210	150	95	10	11	11	M10	37
ND410	345	350	180	235	150	115	10	13	14	M12	63
ND411	345	350	205	270	175	115	12	13	2 * 11	M10	37
ND412	385	350	205	280	175	115	12	13	2 * 11		
ND413	445	350	205	280	175	115	12	13	2 * 11		

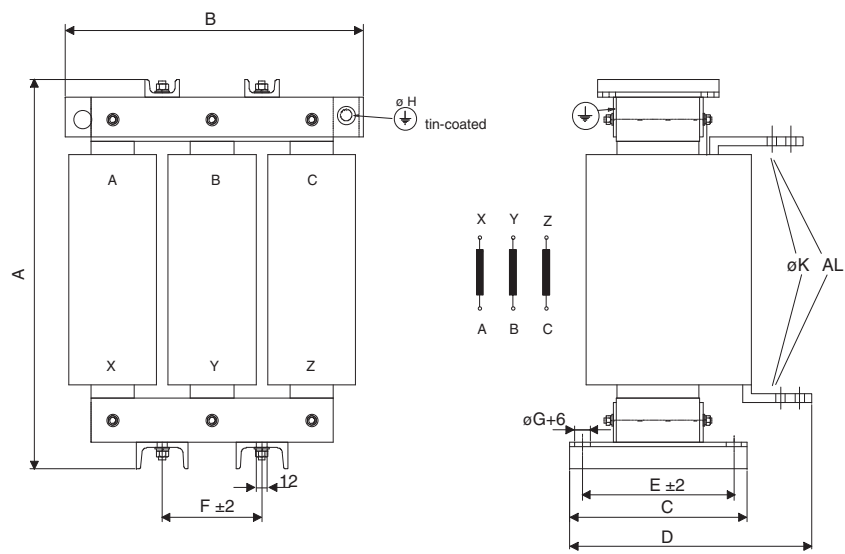

ME_DRO_008_ND409-413_a.ai

Accessories

Autotransformer (T3)

Autotransformer (T3)	Field current [A]	Secondary current [A]	Weight [kg]	Power losses [W]	Fuse F3.2 [A]
		$U_1 = 500\text{ V} \pm 10\%, 50 / 60\text{ Hz}$			
T3, 01	$I_F \leq 6$	≤ 7	15	65	10
T3, 02	$I_F \leq 12$	≤ 13	20	100	16
T3, 03	$I_F \leq 16$	≤ 17	20	120	25
T3, 04	$I_F \leq 30$	≤ 33	36	180	50
T3, 05	$I_F \leq 50$	≤ 57	60	250	63
		$U_1 = 690\text{ V} \pm 10\%, 50 / 60\text{ Hz}$			
T3, 11	$I_F \leq 6$	≤ 7 ①	15	80	10
T3, 12	$I_F \leq 12$	≤ 13 ①	20	125	16
T3, 13	$I_F \leq 16$	≤ 17 ①	30	150	20
T3, 14	$I_F \leq 30$	≤ 33 ①	60	230	50
T3, 15	$I_F \leq 50$	≤ 57	60	320	63



① The 690 V autotransformer input cannot be used for the field converters DCF803-0016, FEX-425-Int and DCF803-0035 (maximum isolation voltage is 600 V).

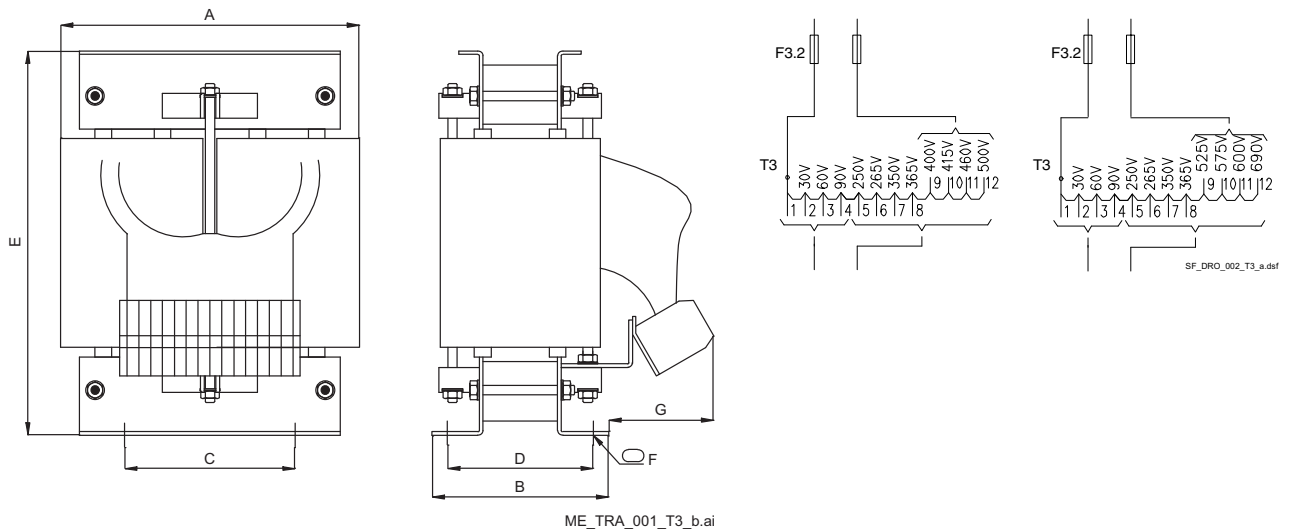



Autotransformer (T3)	A [mm]	B [mm]	C [mm]	D [mm]	E [mm]	F [mm]	Ø G [mm]
T3, 01 / T3, 11	210	110	112	75	240	10 * 18	95
T3, 02 / T3, 12 T3, 03	210	135	112	101	240	10 * 18	95
T3, 13	230	150	124	118	270	10 * 18	95
T3, 04	260	150	144	123	330	10 * 18	95
T3, 14 / T3, 05 T3, 15	295	175	176	141	380	12 * 18	95

Line reactor (L3)

The ND30 is used for single-phase connection of DCF803-0016, FEX-425-Int and DCF803-0035 up to a field current of 16 A.

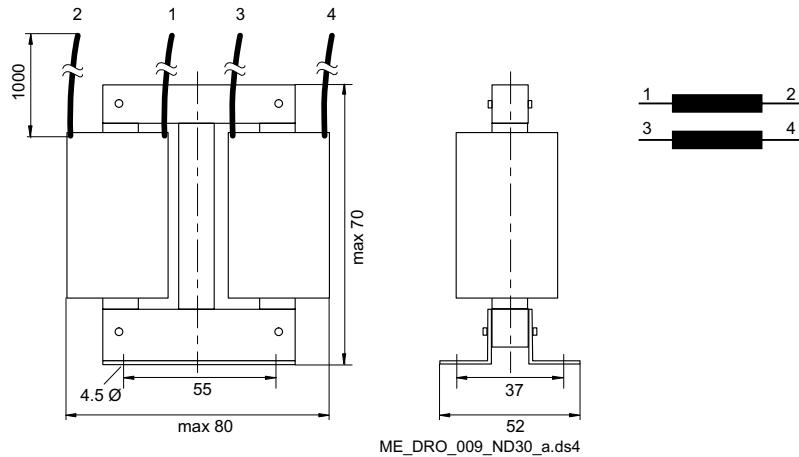
Input voltage: max. 500 V
 Frequency: 50 / 60 Hz



Line reactor (L3)	L3 [μ H]	IRMS [A]	IPEAK [A]	Weight [kg]	Powerlosses [W]	 [mm ²]
ND30	2 * > 500	16	16	1.1	8	2

Connection example

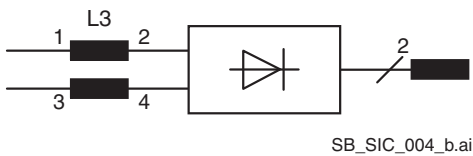

Auxiliary transformer (T2) for converter electronics and fans

The auxiliary transformer (T2) is designed to supply the module's electronics and cooling fans. One transformers power and current allow supplying the single-phase fans and electronics of e.g. two H6 converters.

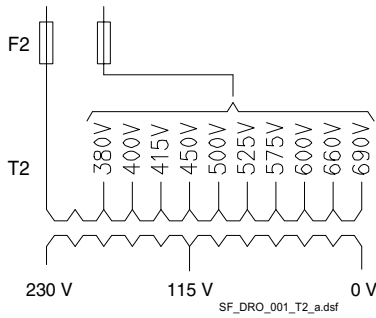

Input voltage: 230 / 380 ... 690 V_{AC} ±10 %, single-phase
 Input frequency: 50 ... 60 Hz
 Output voltage: 115 / 230 V_{AC} single-phase

Transformer (T2)	Power [VA]	Weight [kg]	Powerlosses [W]	Fuse F2 [A]	Secondary current [A]
T2	1,400	15	100	16	6 @ 230 V 12 @ 115 V

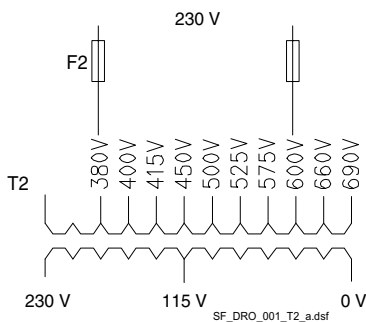
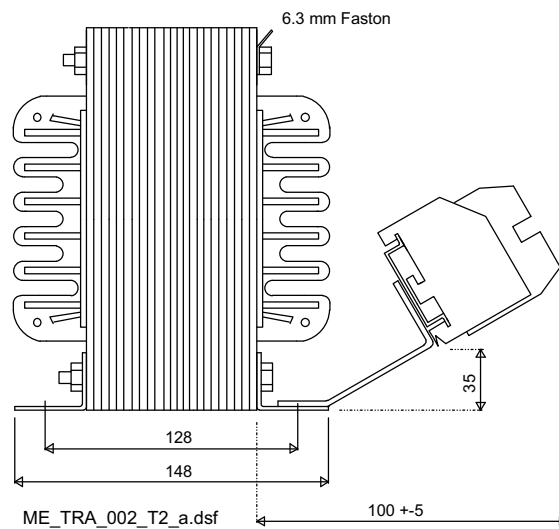
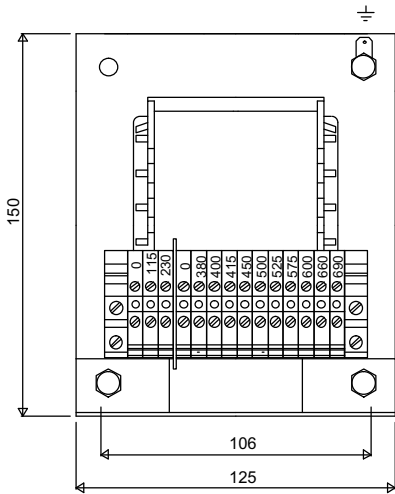

Commissioning hint:

T2 is designed to work as a 230 V_{AC} to 230 V_{AC} isolation transformer to open or avoid ground loops. Connect the 230 V_{AC} at the 380 V_{AC} and 600 V_{AC} tapings according to the drawing on the left hand side.

Supply transformer (T8) for cooling fans

The three-phase autotransformer (T8) is designed to supply the cooling fan in a H8 converter.
Cooling fan: 460 V or 500 V.

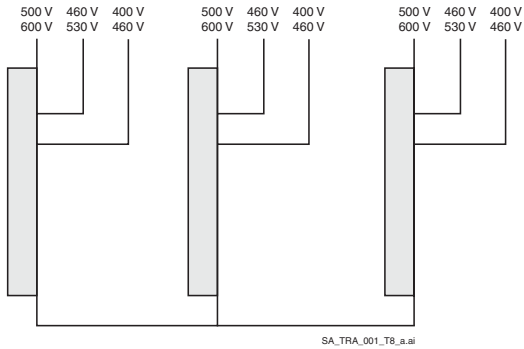

SA_TRA_001_T8_a.ai

Input voltage: 500 / 460 V_{AC} or 600 / 530 V_{AC} ±15 %, 3-phase
 Input frequency: 50 ... 60 Hz
 Output voltage: 400 V_{AC} or 460 V_{AC}, 3-phase

Transformer (T8)	Power [VA]	Weight [kg]	Powerlosses [W]	Secondary current [A]
T8	5,580	20	16	7 @ 460 V

Connection example for cooling fan at 500 V_{AC}.

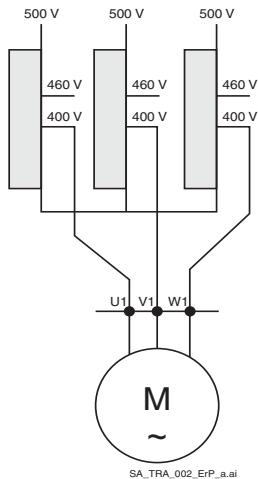

SA_TRA_002_ErP_a.ai

Dimensions

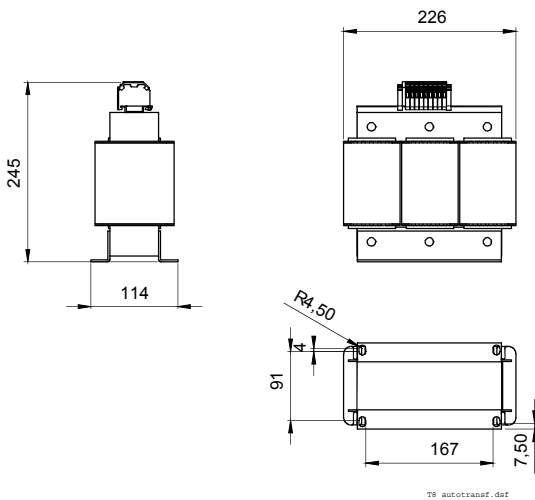

T8 autotransf.dwg

Accessories

Optical cables

Different optical cables are available.

Kind of cable	Connector	cable length	Ident. no.	Fig.
Plastic optic fiber single cable	plug	0.5 ... 30 m	3ADT693324P000x	1
Plastic optic fiber double cable	plug	0.5 ... 30 m	3ADT693318P000x	2
Plastic optic fiber double cable	plug	5 m	3ADT693752P0004	3
HCS silica (double) without plastic jacket	plug	30 ... 50 m	3ADT693355P00xx	4
HCS silica (double) with plastic jacket	plug	50 ... 200 m	3ADT693356P0xxx	5

Figure 1

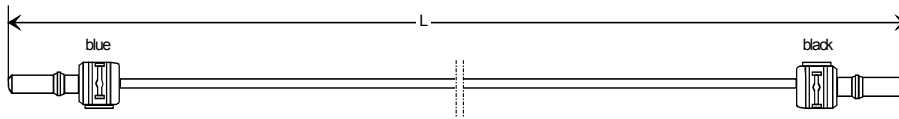

Figure 2

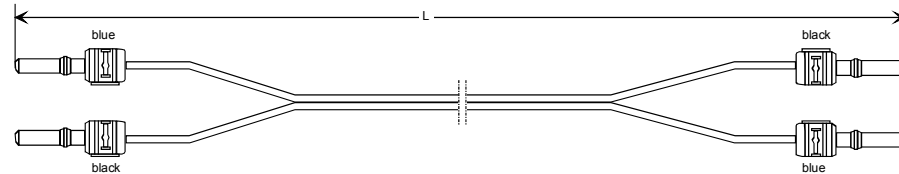

Figure 3

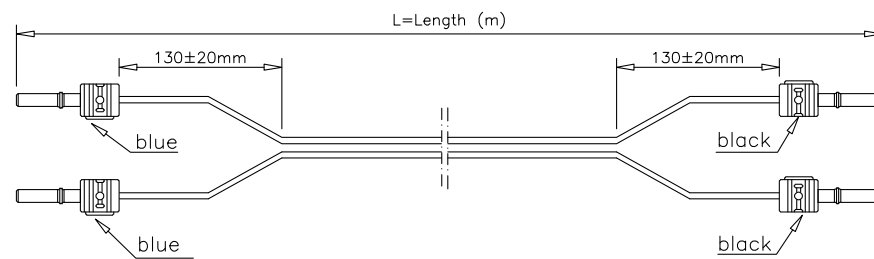

Figure 4

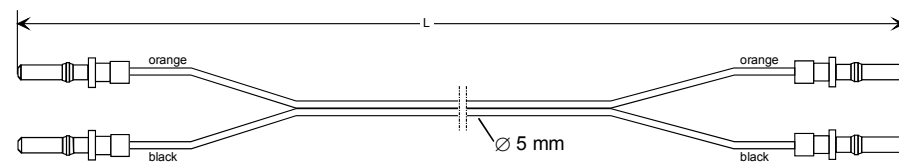
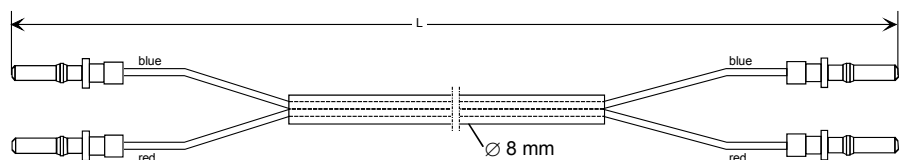
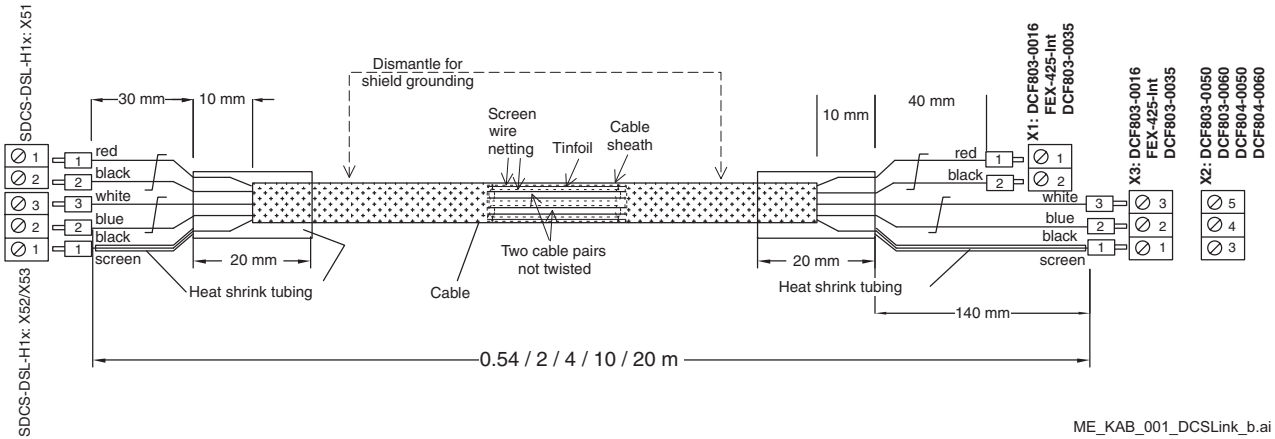

Figure 5



Other cables

DCSLink cable



Recommended connectors

Option	Type	Manufactures description	Picture
FENA-x1	RJ45	HARTING RJ Industrial® 10G Type: 09 45 151 1561	
FBPA-01	D-Sub9	Subcon-Plus-Profib Type: 2744348	
FCAN-01	D-Sub9	SUBCON-PLUS-CAN Type: 2708119	
FEN-xx	D-Sub9 or D-Sub 15 high density	MH Connectors Sub-D9, 90° Type: MHDCMR09-K (just the housing, use standard D-Sub9 or D-Sub15 high density connectors)	



ABB Automation Products

Wallstadter Straße 59

D-68526 Ladenburg

Germany

Telefon: +49(0)6203-71-7608

Telefax: +49(0)6203-71-7609

www.abb.com/dc-drives



462R0401A9120000

3ADW000462R0401_Rev D
03_2019