

Pendulum Switch EL 101 D

For level detection of granulated or pulverised bulk materials and as malfunction indicator



Overview

The EL 101 D Pendulum Switch can be used as control device in all circumstances where a state change causes it to leave its vertical position.

A possible application is as fill level indicator in containers containing granulated or pulverised materials in which the growing material cone causes the deflection.

On conveyor belts, it can be used to indicate the presence of material. Furthermore, it can be applied as water flow detector at watergates or streams or as limit switch in conveyor systems. Apart from this, its mode of operation allows for a number of other further fields of application.

The EL 101 D Pendulum Switch has a very sturdy design, which makes it suitable for applications under roughest operating conditions. Even hard strokes or shocks can be tolerated.

The pendulum switch is installed into in einem thick-walled grey cast iron housing with screwed cover. containing an eyelet for the suspension of the device and a cable gland for the introduction of the connection cable.

The housing bottom comprises an internal thread R1" for the connection of a construction (tube, valance or protective plate), to support the deflection of the housing from its vertical position.

The EL 101 D is designed for direct switching of an actuator circuit. When deflected from its vertical position, it carries out a switching process. An inclination of only 20° causes a freely moving steel ball inside the housing to operate a special microswitch.

Features

- Reliable contact
- Robust design for roughest conditions

EATON

Powering Business Worldwide

Specifications

Housing	Grey cast iron with ring screw M12 Bottom part with mit internal thread R1" for tube, valance or protective plate
Colour	Grey
Ingress protection	IP 66 according to IEC 60529
Protection class	I
Type of contact	Change-over contact
Switching capacity	250 V/15 A
Switching point	Approx. 20° deflection from vertical position
Cable glands	M20 x 1.5
Connection terminals	2.5mm ²
Operating conditions	Indoors and outdoors
Operating position	Pendulous
Operating mode	Continuous operation
Temperature range	
Operation	-25 °C to +60 °C
Storage	-25 °C to +70 °C
Weight	Approx. 10 kg

General arrangement drawing (all dimensions in mm)

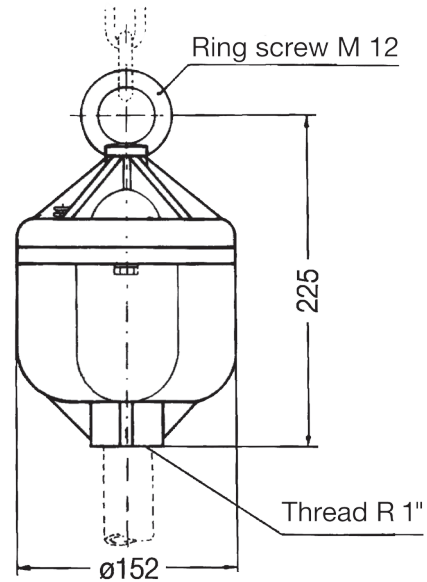

Ordering data

Type	Designation	Nominal voltage	Switching capacity	Art. No.
EL 101 D	Pendulum Switch	250 VAC	15 A	FHF 321 605 01