

Ex Strobe Light BZ2/BD22

Optical signalling device for zones 2 and 22



Overview

In potential explosive atmospheres it is often necessary to use optical signals for warning, indicating and signalling purposes. The Ex-Strobe light BZ2/BD22 offers these signalling options. The item is designed for continuous operation.

The BZ2/BD22 Strobe Light is activated by connecting the supply voltage. It may be delivered with different dome colours. The sturdy housing made of impact-resistant polycarbonate is realized in protection class IP 66 and allows for indoor and outdoor applications. The dome consists of impact-resistant coloured polycarbonat.

A powerful xenon flash tube transforms the electrical energy stored in the flash capacitor into light flashes with a high degree of efficiency.

Features

- II 3 G Ex nR IICT5 Gc
II 3 D Ex tc IIIC T85 °C Dc
-20 °C ≤ Ta ≤ +50 °C
(bei 12 VDC/24 VDC)
- II 3 G Ex nR IICT4 Gc
II 3 D Ex tc IIIC T85 °C Dc
-20 °C ≤ Ta ≤ +40 °C (bei 120 VAC/230 VAC)
- Ingress protection IP 66
- Flash energy 15 joule
- Protection class II

General arrangement drawing (all dimensions in mm)

Certification

Protection type	II 3 G Ex nR IIC T5/T4 Gc II 3 D Ex tc IIIC T85°C Dc
-----------------	---

Specifications

Housing	Impact-resistant polycarbonat
Colour	Black
Ingress protection	IP 66 according to EN 60529
Protection class	II
Cable glands	M20 x 1.5 with ATEX certification, 2 x blind plug M20 x 1.5
Connection terminals	For line diameters up to 2.5 mm ²
Flash energy	15 joule
Flash frequency	60/min
Operating conditions	In dry or damp rooms and outdoors
Operating position	Any
Operating mode	Continuous operation
Temperature range	
Operation	T5: -20 °C ≤ Ta ≤ +50 °C (at 12 VDC/24 VDC) T4: -20 °C ≤ Ta ≤ +40 °C (at 120 VAC/230 VAC)
Storage	-30 °C to +80 °C
Weight	Approx. 1.4 kg

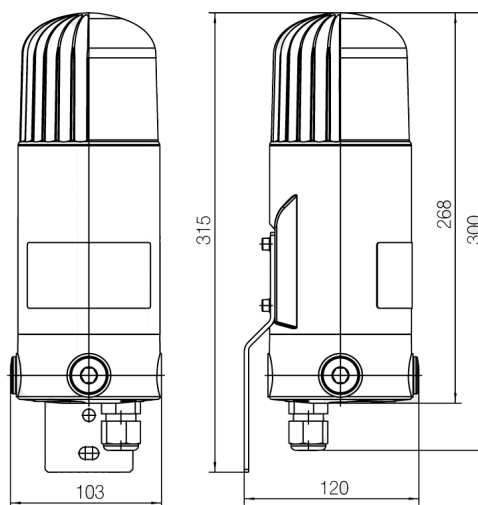
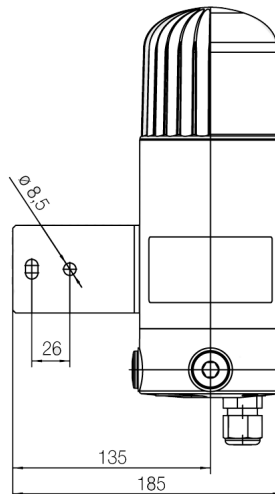

Ordering data

* The following code is designed to help in selection of the correct unit. Build up the reference number by adding the respective colour code for each component from the box on the right.

Type	Designation	Input voltage	Tolerance	Current consumption	Art. No.*
BZ2/BD22	Strobe Light	230 VAC, 50-60 Hz	-10/+6 %	0.13 A	FHF 224 952
BZ2/BD22	Strobe Light	120 VAC	-10/+6 %	0.45 A	FHF 224 956
BZ2/BD22	Strobe Light	24 VDC	15-32 V	0.55 A	FHF 224 954
BZ2/BD22	Strobe Light	12 VDC	9-16 V	1.1 A	FHF 224 953

transparent	01
red	02
orange	03
green	04
blue	05