

SP26 thermal image analogue series - UL range

PTZ camera station,
ordinary location



Overview

The Oxalis SP26 thermal imager is a PTZ camera station for use in onshore, offshore, marine and heavy industrial environments.

The camera housings are designed specifically for the Americas markets or where UL ordinary location standards have been specified where thermal imaging is required for specific process or security applications.

The base unit carries dual NPT cable entries with easy access for cable termination during installation as standard, maximising compatibility and ease of use with existing installations.

Our camera stations are designed and manufactured for longevity in harsh environments, require minimal maintenance and are fully certified to UL standards.

See separate datasheets for other global certification ranges.

Features

- Electro-polished 316L stainless steel on all welded assemblies
- Camera station window in toughened glass
- Pole or wall mounting options (see separate datasheets)
- NPT entries as standard
- 3 different size lens options
- 4 resolution/frequency rating options
- Various camera module options
- Options also available for IP, analogue, hybrid, IP over Coax and direct fibre out* - see specific datasheet
- Supply voltage options (24 VAC, 110 or 230 VAC, 50/60Hz)
- -58°F to +158°F* operating temperature
- IP66/67

*Model dependent

Specifications

Features	
Sun shield	Standard stainless steel 316L mirror finish
Integral wiper	Optional (silicone wiper blades that are resistant and do not perish after long exposure to ozone, UV, ice, snow, heat or cold)
Integral demister	Standard
Washer systems	Compatible with Oxalis SW washer tanks (see separate datasheets)
Pan speed (maximum)	45° per second
Tilt speed (maximum)	24° per second
Pre-set positional accuracy	64 Presets: positional accuracy±0.1°
Telemetry receiver	Integral - Pelco D, P standard protocols (others to specification)
Rotation	Continuous Pan or 350° Rotation (+/- 175° from straight ahead)
Analogue direct fibre out	Optional singlemode 9/125µm or multimode 50/125µm video and data fibre optic transmission, mounted inside the camera station
Type approval	DNVGL-CG-0339, 2016 (copper transmission only)
Ingress protection rating	IP66/67
Electrical	
Supply voltage options	24 VAC, 110 or 230 VAC, 50/60Hz
Power consumption	85W maximum (143W with low temperature operation)
Electrical connections	Terminal block for power, data and video specific to camera configuration
Cable entry	2 x ¾" NPT located in base
Mechanical	
Body material	Electro-polished 316L stainless steel on all welded assemblies
Fixings material	A4 stainless steel
Camera station window	Internal AR and external carbon coated germanium Ø50 mm
Mounting options	Pole or wall (see separate datasheets)
Operating temperature	From -58°F to +158°F (model dependent)
Weight (lb)	Up to 70.5lb depending on configuration
Thermal core module options	
T336 7.5-8.3Hz	Uncooled VOx microbolometer thermal imaging camera, including TCI Interface PCB for functionality over standard RS485 protocol Commands 336 x 256 resolution, 17µ pixel size, 7.5Hz NTSC/8.3Hz PAL exportable frame rate, digital detail enhancement
T640 7.5-8.3Hz	Uncooled VOx microbolometer thermal imaging camera, including TCI Interface PCB for functionality over standard RS485 protocol Commands. 640 x 512 resolution (PAL), 17µ pixel size, 7.5Hz NTSC/8.3Hz PAL exportable frame rate, digital detail enhancement
T336 25-30Hz	Uncooled VOx microbolometer thermal imaging camera, including TCI Interface PCB for functionality over standard RS485 protocol Commands 336 x 256 resolution, 17µ pixel size, 30Hz NTSC/25Hz PAL frame rate, digital detail enhancement. Subject to export restrictions and licensing
T640 25-30Hz	Uncooled VOx microbolometer thermal imaging camera, including TCI Interface PCB for functionality over standard RS485 protocol Commands. 640 x 512 resolution (PAL), 17µ pixel size, 30Hz NTSC/25Hz PAL frame rate, digital detail enhancement. Subject to export restrictions and licensing
Thermal core lens options	
19mm lens	FoV 17° x 13° (336 x 256) / FoV 32° x 26° (640 x 512) Detection of object 4m x 1.5m: Typical 1550m
25mm lens	FoV 13° x 10° (336 x 256) / FoV 25° x 20° (640 x 512) Detection of object 4m x 1.5m: Typical 2200m
35mm lens	FoV 9.3° x 7.1° (336 x 256) / FoV 18° x 14° (640 x 512) Detection of object 4m x 1.5m: Typical 3000m

General arrangement drawing (dimensions in inches and mm)

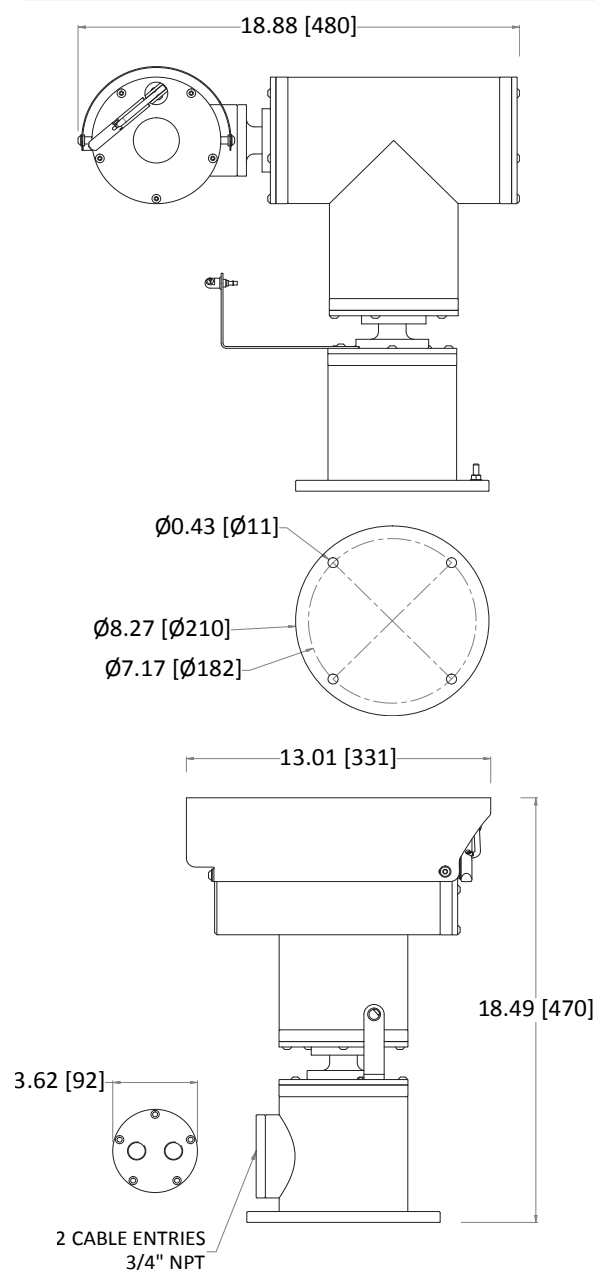

Ordering requirements

The following code is designed to help in selection of the correct unit. Build up the reference number by inserting the code for each component into the appropriate box

